

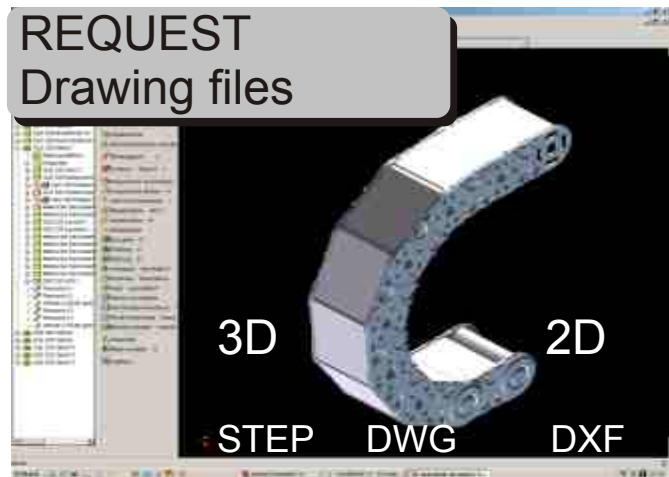







Design guidelines	4
Arrangements	8
Wiring	11
Strain reliefs	12
Order informations	14



Kolibri  18	PKK  48	PLE  66	SLE  80
Kolibri applications 19	PKK applications 49	PLE applications 67	SLE applications 81
Kolibri dimensions 20	PKK dimensions 50	PLE dimensions 68	SLE dimensions 82
Kolibri types 21	PKK types 52	PLE types 69	SLE types 84
Kolibri sizes 22	PKK sizes 54	PLE sizes 71	SLE sizes 86
Kolibri height 10 23			
Kolibri height 15 24			
Kolibri height 22 26			
Kolibri height 30 28			
Kolibri height 40 33			
Kolibri height 50 35			
Kolibri height 65 37			
Kolibri parts 39	PKK parts 55	PLE parts 72	SLE parts 87
Kolibri assembly 40	PKK assembly 56	PLE assembly 73	SLE assembly 88
Kolibri flanges 42			SLE connectors 83
Kolibri part numbers 44	PKK part numbers 62	PLE part numbers 76	SLE part numbers 92
			SLE accessories 98

GKA  100	SFK  106	PFR  108	troughs  110
GKA dimensions 102	SFK dimensions 106	PFR dimensions 108	gliding applications 113
GKA connectors 103	SFK connectors 107	PFR connectors 109	
GKA types 103			
GKA sizes 104			
GKA parts 105			

ENERGY CHAIN SYSTEMS  114	SYSTEM MARATHON  116	SYSTEM ALLROUND  118	SYSTEM ELTOLA  119
SYSTEM REINTEC  120	materials 122	safety instructions 127	

Selection of the energy chain and material

For most applications energy chains made of plastic is your first choice. Chemical resistance, light weight and low costs are the major advantages. Steel chains are used under extreme payloads and high mechanical or other particular requirements. For extreme cycles the hardened (carburized) steel is required to achieve long life.

Calculation of cross-section

First, the cross-section required for the wires is determined, and then specific motions or arrangements, aggressive environmental conditions or other factors lead to your selection.

A pre-selection of the product series may use the fields of application (see product series chapter).

All lines must be able to move freely in the energy chain. This requires an individual clearance to be taken into account for each line:

round cable:	10% of the diameter
flat cable:	10% of the cable width and height
hoses:	20% of hose diameter

Optimum requirement is the separation of all lines by means of individual chambers. Especially with varying diameters or multi-layer wiring a separation by vertical and horizontal dividers is required.

If several lines are to be laid in one chamber, the chamber dimensions have to be restricted so that they maintain their relative positions.

Even multi-layer arrangements of flat cables have always to be separated with horizontal dividers.

When using pressure hose a change in length has to be taken into account through additional clearance in the chain bow (radius), which can be achieved by a corresponding chain height (a).

The distribution of the energy chain cross-section should be symmetrical in order to ensure a uniform load. In addition heavy lines are laid out close to the links to minimize the bending loads on the transverse bars.

Determination of the bending radius

The bending radius of the energy chain is determined by the minimum permissible bending radius of the cables and hoses, the available installation space and the polygon oscillation PA of the energy chain.

In general, a minimum bend radius of $10d$ is considered, where d is the largest existing line diameter. Cables with smaller minimum bend radii are available by some manufacturers.

The polygon oscillation PA influences the moving of an energy chain. A large bend radius at the same pitch results usually in a calmer movement of the energy chain.

The installation space must have a height of more than $2R + c$, where R is the bending radius and c is the link height of the energy chain. The pretension of the energy chain should also be considered.

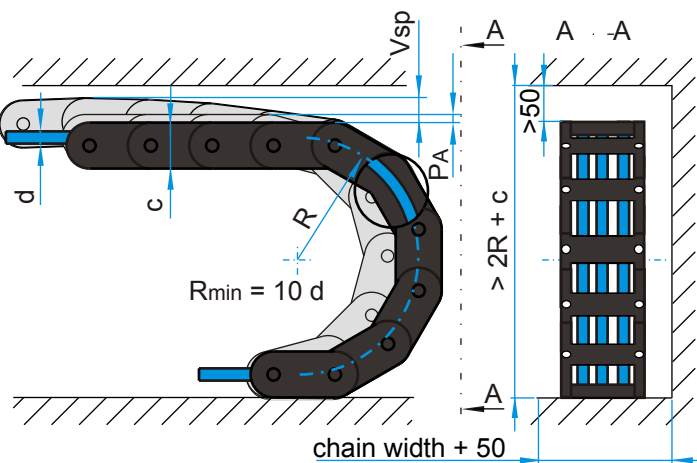
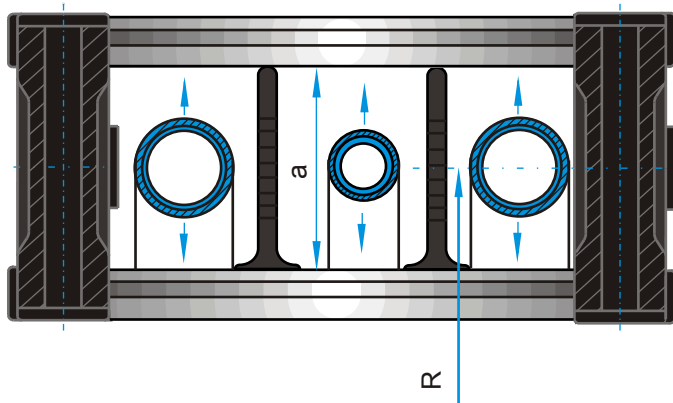
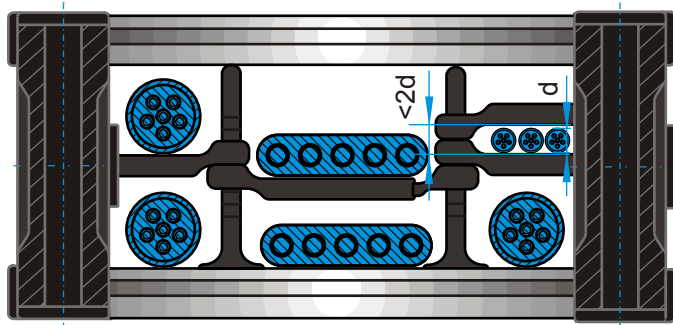
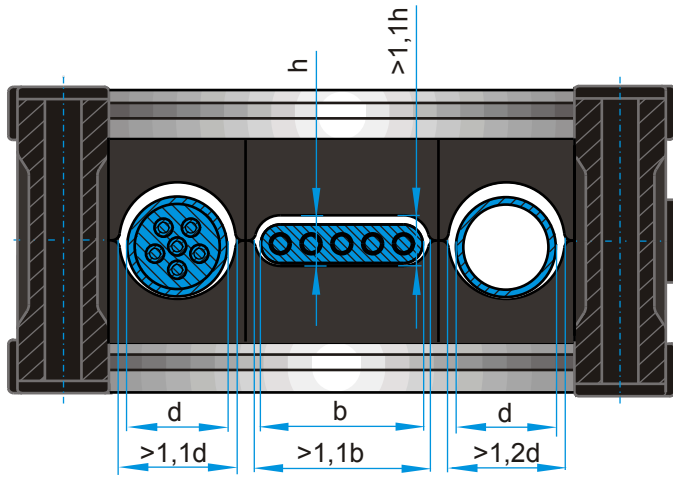

Energy chain length

In standard applications the fixed connector of the energy chain is arranged in the middle of the travel distance. The moving connector moves horizontally over the fixed connector between the end positions of the travel. The required length of the energy chain between the first and the last pivoting link is then determined as follows:

$$L = \frac{LV}{2} + 4 R$$

- L length of the energy chain
- LV length of travel
- R bending radius of the energy chain

If the fixed connector is not in the middle of the travel, the energy chain has to be extended by a displacement of x:

$$L = \frac{LV}{2} + 4 R + x$$

- x offset of the fixed connector

After the selection of the energy chain, the length is rounded up to the link pitch. This length is the ordering length of the energy chain.

The connectors height is double bend radius plus link height:

$$HA = 2 R + c$$

- HA connector height
- c link height of the energy chain

Review of the free carrying length

The additional load is the weight of all cables and hoses, divided by the length of the chain:

$$m_s = \frac{mL}{L}$$

- mL cable weight
- mS specific additional load

Thus with calculated additional load and the help of the load diagram the free carrying length of the energy chain can be verified.

If the additional load is too high for a particular chain an energy chain with greater free carrying length is chosen or constructive changes have to be done that allow the operation with the chosen energy chain (eg, gliding arrangement, support rollers, SYSTEM MARATHON or similar).

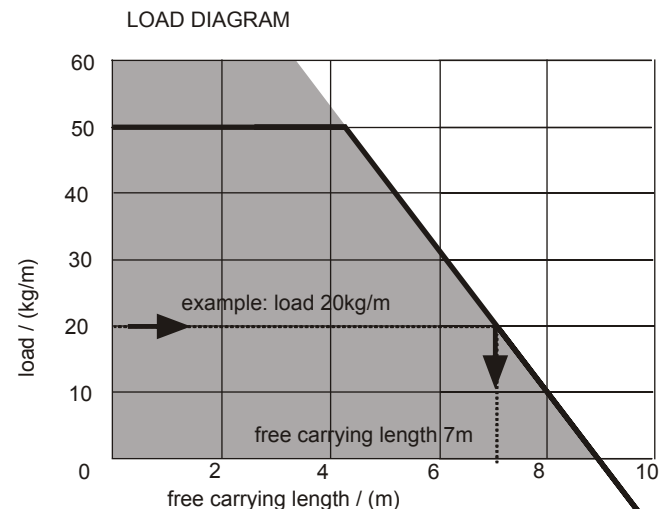
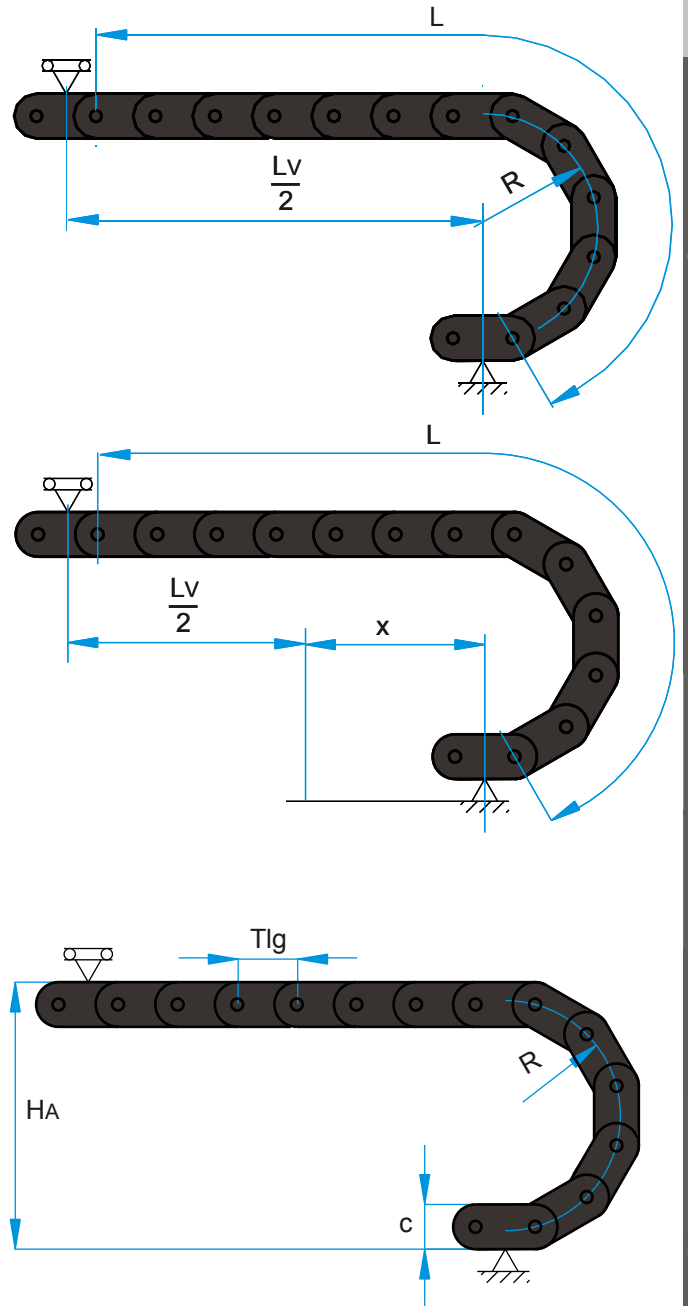

Pretension and permissible sag

ekd energy chains are supplied with pretension. Exceptions are energy chains for vertical or sliding arrangements as well as on the side lying energy chains, for example, in a circular arrangement.

The pretension is a manufacturing tool to achieve energy chains with increased free carrying lengths.

The values for the pretension is set by the manufacturer. ekd energy chains made of steel are manufactured with 5 mm / m and plastic energy chains up to 25 mm / m as pretension with no load.

The sag is due to the additional load and the weight of the energy chain. Due to the significantly lower elongation of steel (0.2% linear elongation) compared to plastics the permissible sag of the steel chains is limited lower than for plastic energy chains.

On the other hand, the effect on plastic energy chains of a long-term static load with a long unsupported length of the upper strand chains will increase the sag (creeping of plastics).

Elevated temperatures and humidity increases this effect. The sag of energy chains is also increased by use-wear.

The maximum allowable sag can only be judged in the assessment of all operating conditions. Within the limits for the free carrying length specified in the load diagram the sag is within the permissible range at normal operating and environmental conditions.

In addition the following factors have to be taken into account:

Using toughs and slow moving energy chain sag is limited.

For high accelerations and high travel speeds too much sag is a problem. A defined force application at the moved connector is not guaranteed and uncontrollable chain oscillations can occur. Thus the energy chain material is subjected to extreme dynamic stresses.

In such cases, corrective steps should be taken.

The first step is the selection of an energy chain with increased free carrying length. If this can not be done, these are the following alternatives:

Support rolls and support rails

Support rollers can increase the maximum travel L_v of steel chains by up to four times the free carrying length L_f .

With additional support rollers and a support rail the maximum range of movement can be expanded up to eight times the free carrying length.

The use of support rollers with support frames, is limited to speeds below 1 m/s.

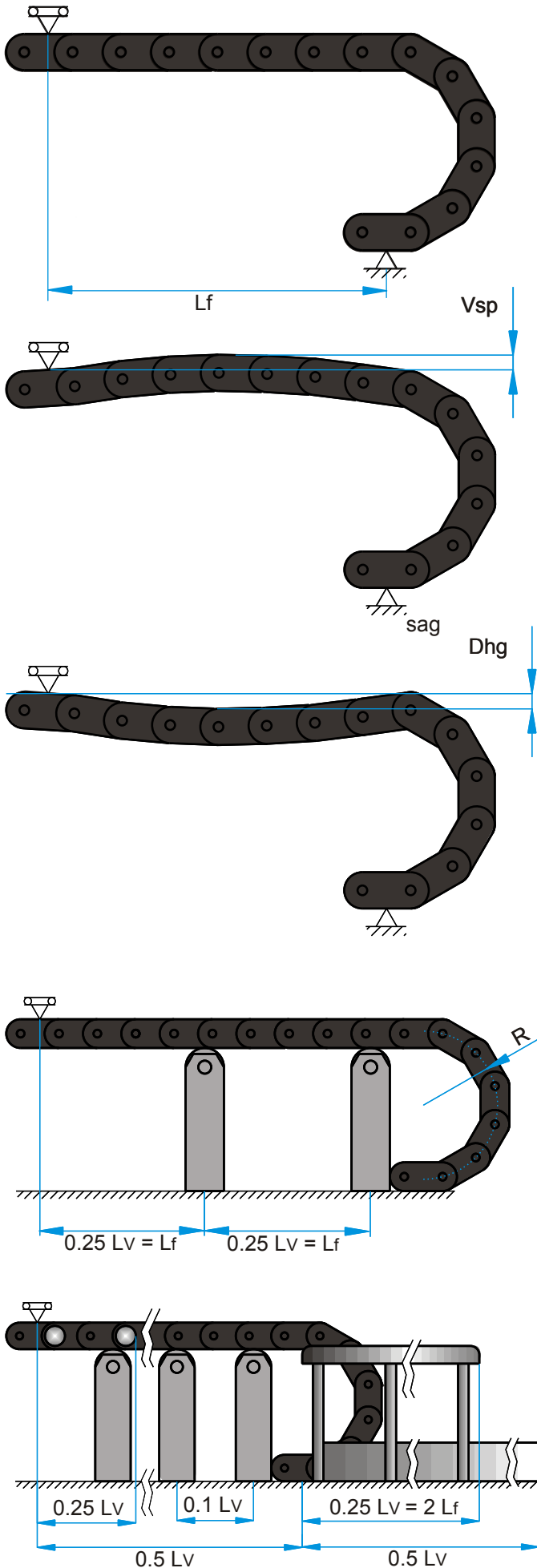

Raised trough

This type is mainly used with plastic energy chain applications. As with the use of support rolls the maximum travel can be increased up to four times the free carrying length.

Because of the larger permissible sagging, support rolls are not suitable for plastic energy chains.

Support carriage

For long travel distances and high additional loads support carriages can be used with reverse travelling energy chains. The side-mounted support rolls carry the energy chain and move the support carriage.

The energy chains now only face pull forces and through this an extremely long life is achieved even at high additional loads.

SYSTEM MARATHON

The patented SYSTEM MARATHON for unlimited travel is also designed for high speeds and high accelerations. The upper run is running with supporting rollers over the entire travel on continuous flat rails and the rollers swing in the radius to lay down the energy chain at the bottom profile. In the back movement the rollers swing out again and lead the energy chain without wear over the entire travel. The SYSTEM MARATHON is not dependant upon the type of energy chain and therefore steel energy chains are as equally suitable as plastic energy chains.

Gliding energy chains

Gliding energy chains require guiding the upper run in a continuous trough. In addition, the first half of travel slide bars are mounted on the energy chain is extended via the fixed end in the middle of the travel out up to the starting point to create a continuous gliding plane (see also chapter troughs).

With high dynamic demands on the energy chain, lowering the moving connection end may be necessary to result in a better introduction of push forces into the energy chain.

In travels over 30 m, velocities above 1.5 m / s and acceleration of 1 m/s² lowering the moving end is recommended and requires an additional length of the energy chain. Chain links with a opposite bend radius minimize the required additional length and minimize oscillations of the remaining free carrying length of the energy chain.

PKK, PLE and SLE energy chains for gliding arrangements are preferably equipped with sliders that can be replaced after reaching the wear limit without dismantling or replacing the energy chain.

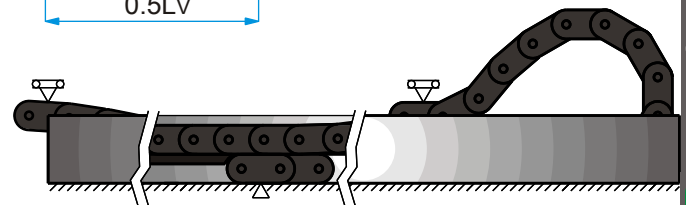
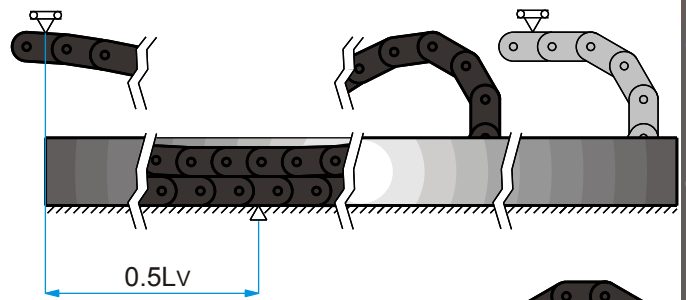
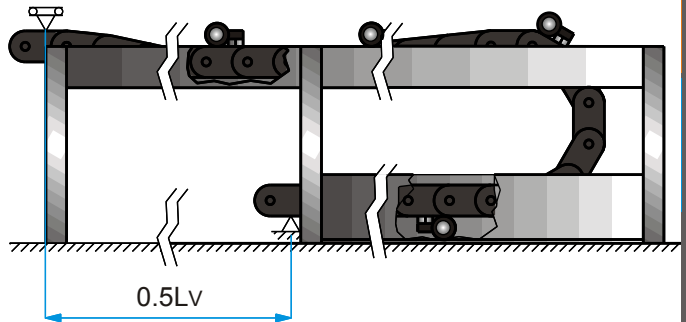
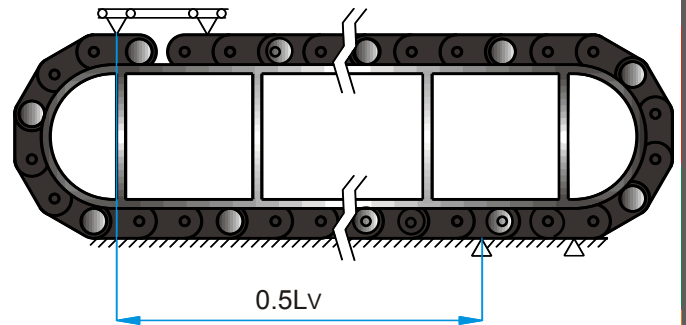
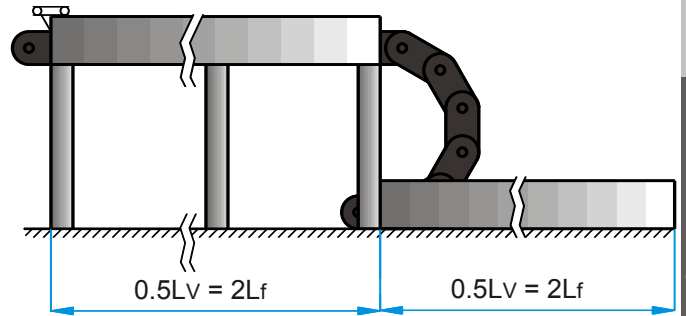

B = moving connector
F = fixed connector
normal
(not specified in order)

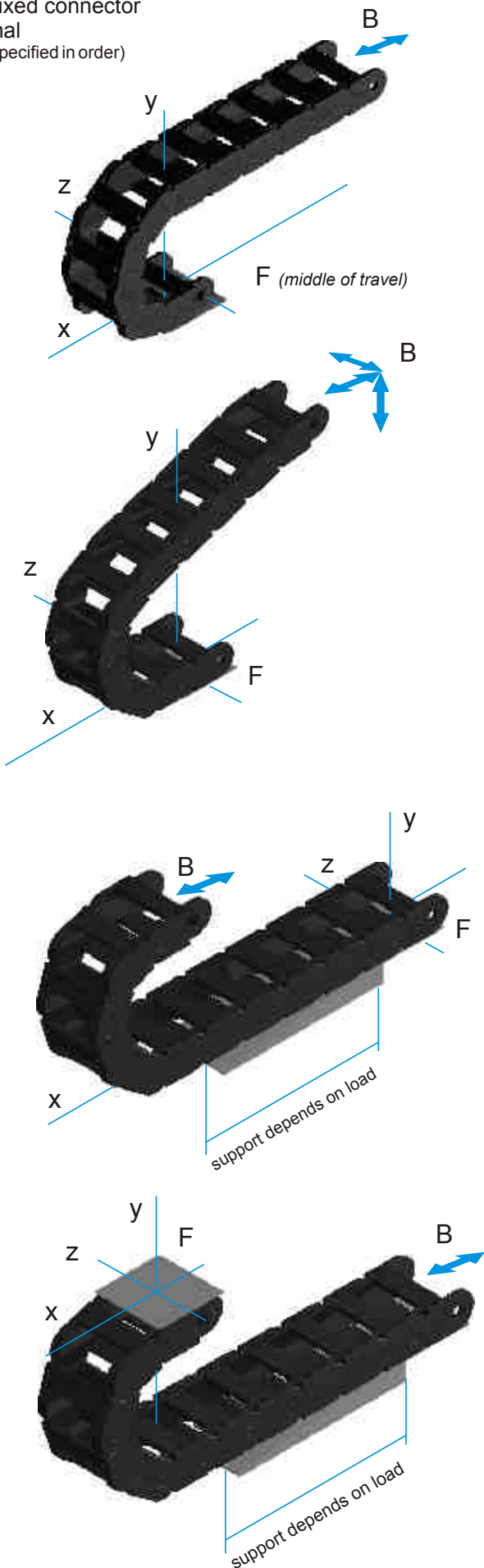

ARRANGEMENTS

normal arrangement (n)

In the **normal arrangement** the fixed connector is usually on the first link in the lower strand in the middle of the travel. The moving end connector is moving the chain in a straight line lengthwise at a height of $2R+c$ over the entire travel. The upper strand is steadily reduced through the bending of the individual links until the whole chain length is taken to the bottom or in a trough. This arrangement allows maximum speeds and extreme acceleration with optimum durability.

multiaxial (m)

In the **multiaxial arrangement** is a vertical and horizontal motion of the driver along the x-axis (travel direction) and one or more movement in the y- or z-direction. While running in the y-direction may be done by any conventional energy chain, the movements in the z-direction require the energy chain system ALLROUND.

free overhang (f)

In contrast to the normal arrangement the freely exceeding lower strand is supported only partially by a substructure. Due to the high weight load on the lower strand in this arrangement only significantly reduced travel distance is possible.

moved end downside (u)

If the driver is positioned in the lower, due to the heavy weight only a reduced travel distance is possible (see above).

nested travel (i)

The arrangement of two or more energy chains with different bending radii or even different energy chains makes sense when using a variety of cables and hoses together. The energy chains are moved together by a common driver.

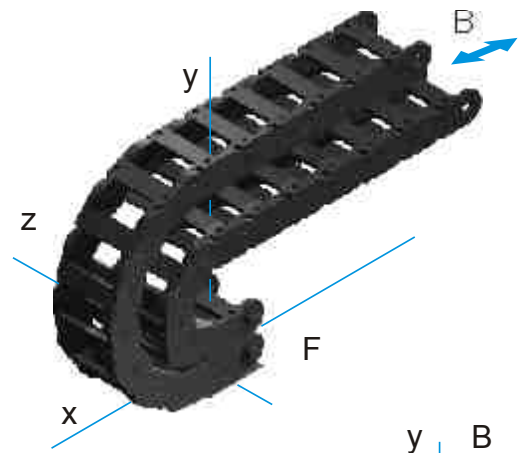

gliding arrangement (l)

If the free carrying length is exceeded, the energy chain changes into a gliding state. In this arrangement, use energy chains without pretension. A trough is required (see chapter troughs). Sliders increase the lifespan and can be replaced if necessary.

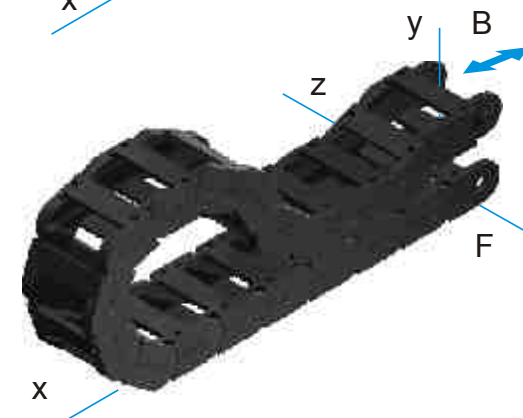

vertical travel (s)

Vertical travel arrangements are often installed in systems in which multiple linear axes are coupled. In this arrangement energy chains without pretension are used to prevent buckling of the energy chain. The weight of the lines and of the energy chain has to be placed and pushed by the straight part of the chain.

The energy chain should be arranged so that optional cross accelerations are in the y-direction and be caught by a supporting.

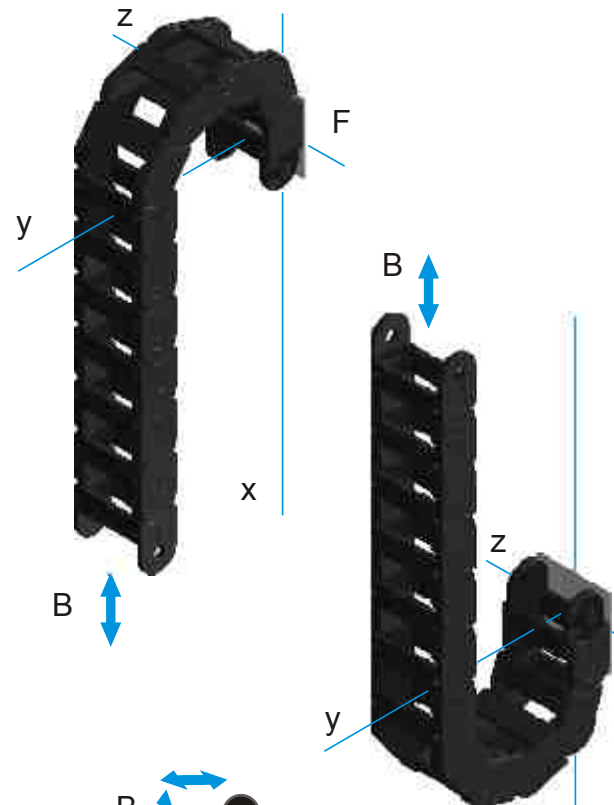

vertically hanging (h)

Elevators, high-bay stores and doors are typical applications for energy chains in vertically hanging arrangement. In this arrangement the energy chain is predominantly tensile stressed. Lateral acceleration should be layed if any, in the y-direction. Energy chains are without pretension.

hanging multiaxial (hm)

The energy chain ALLROUND provides the combination of linear and rotary motion.

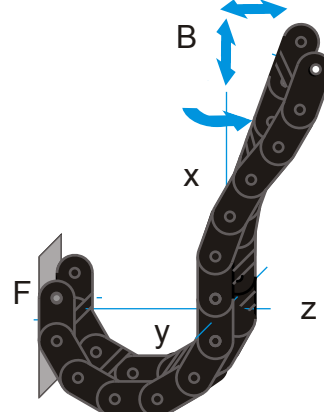

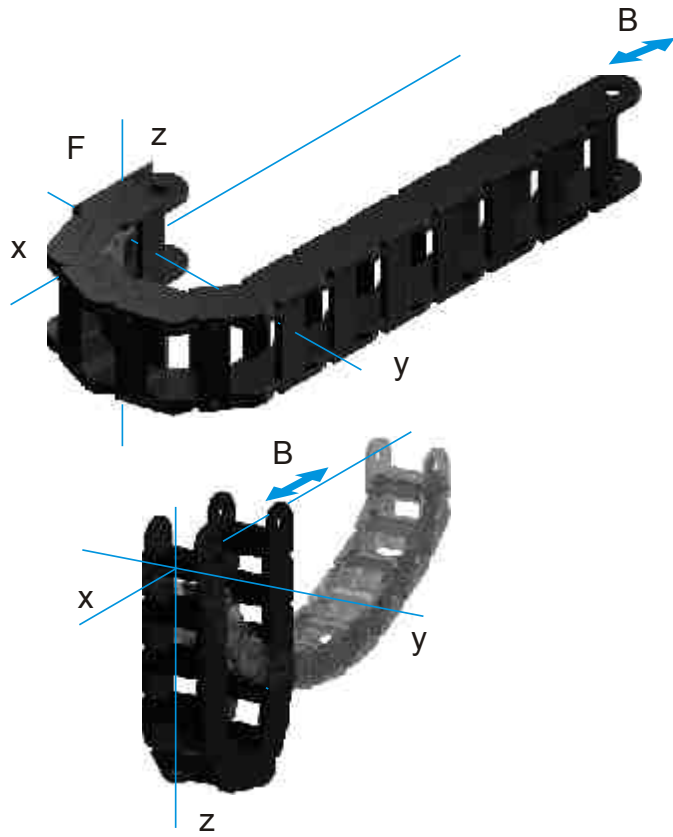

horizontal (w) on the side

Energy chains are arranged horizontally lying on their side, for example, if the space does not allow a normal arrangement. In some cases, lying on its side provides an alternative for very long traverse at low speeds and strokes. In this application mainly chains without pretensionare used.

In general, suitable guide troughs and gliding discs or rollers are required.

driving apart (a)

With energy chains moving apart the calculation of the energy chain length does not follow the usual pattern, but be adapted to the individual requirements of the application.

circle (k) on the side

The circular motion is a special form of chain movement. For circle movement a part of the energy chain has to be manufactured with an opposite bending radius R2.

The outer radius R3 is derived from the link height, the bending radius of the energy chain R1 and the opposite radius R2.

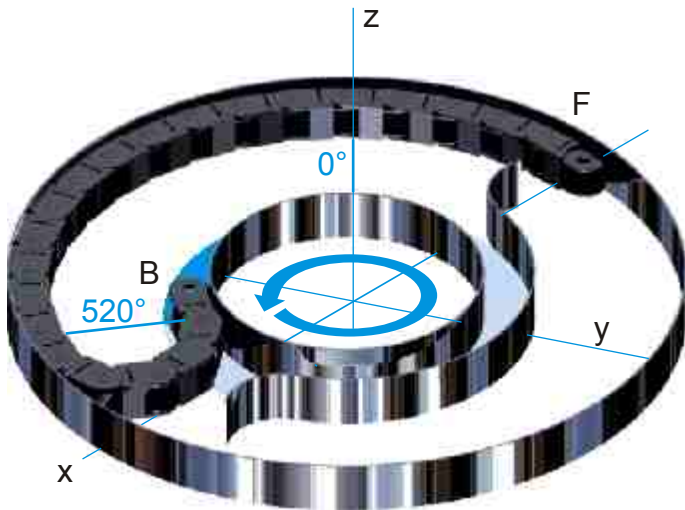
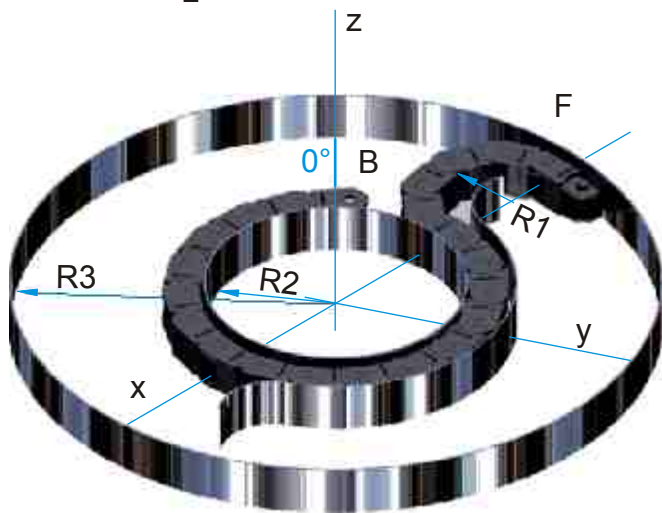

This type of horizontal arrangement allows rotation up to 520°. A customized guide channel is required.

For laying in energy chains only highly flexible cables with permissible bending radii and sufficient dynamic capacity suitable. The cables have to be laid twist free to move freely lengthwise. Cable on a reel should be unrolled in the reverse winding direction and placed in the extended state in the energy chain. For intermediate storage the lines are ideally laid out straight. The material relaxation occurs in this case facilitates a twist-free installation.

The distribution of the chain interior must prevent mutual interference between the wires with dividers or wrap clamping of different diameters safely, so that each line can move freely in the longitudinal direction (see design guidelines). In particular in the energy chain radius tensile stressed wires increase wear drastically and reduce the reliability. A fixation of the wires or a bundle of several lines using cable ties or the like within the energy chain can also cause damage.

Strain Relief

With long travel distances and high speeds the cables should be attached with strain relief only at the driver end. For free carrying energy chains recommend for aesthetic reasons, a strain relief on both ends. The distance of strain relief to the bending stressed area depends on the particulars of the line manufacturer. Hydraulic hoses have special needs.

Integrated strain relief

In this space-saving type the strain relief is directly attached to the plastic dividers (PZ) in the first link of the energy chain (note the mounting direction of PZ!).

In order to avoid premature line wear caused by dynamic loads, a small excess length of the chain is recommended.

Combined strain relief

The combined strain relief combines the advantage of a sufficient distance from the bending line areas to the strain relief by the simple and space-saving installation of the integrated strain relief. The anchor profile is provided to the drilling dimensions of the energy chain and attached to the chain.

The lateral insertion and extraction of strain relief elements is through the C-profile.

Separate strain relief

The separate strain relief is recommended for high dynamic loads and large line diameters. A sufficient distance of the strain relief to the moved line areas and length compensations are easy to implement. In this variant the lateral insertion and extraction of the strain relief elements with no installation work on the cable carrier is possible.

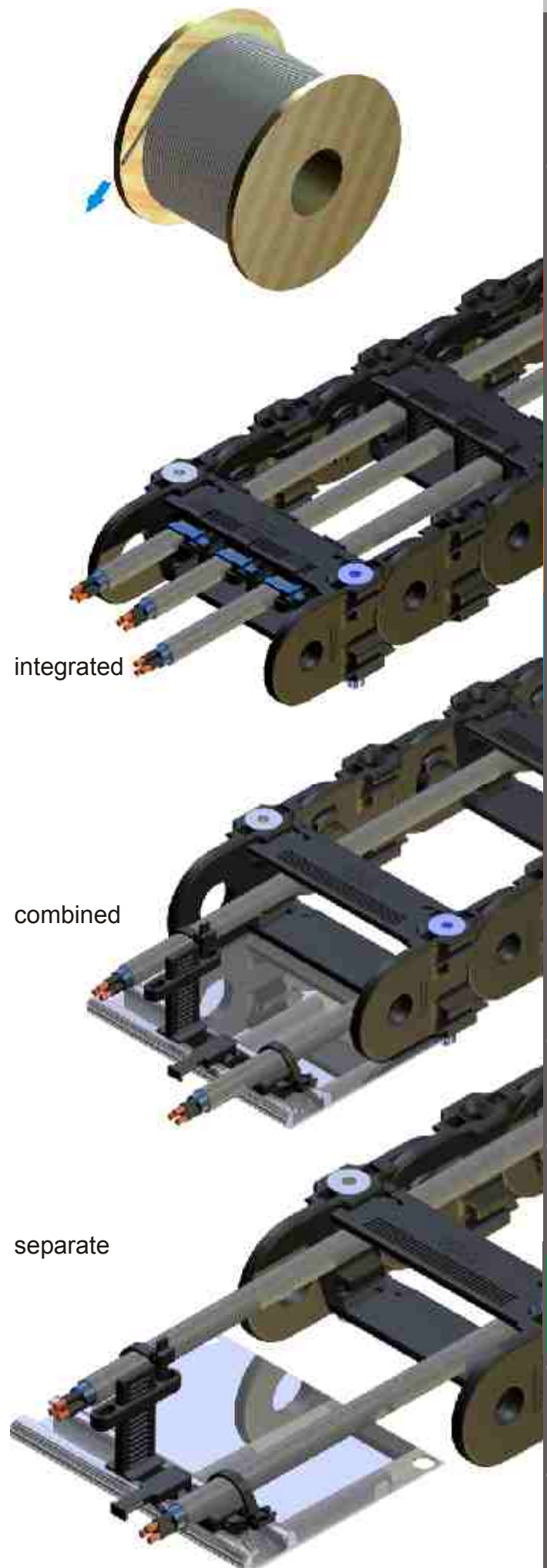

STRAIN RELIEF

anchor profile ZLP

The aluminum anchor profile is used to mount various strain relief elements. Both the distance to the energy chain as well as the positioning of the strain relief elements can be easily designed. The length of the anchor profile and the drilling dimensions are determined by the dimensions of the energy chain.

ZLP XX part no. 1163
(xx = chain width)



strain relief stay ZLS

The strain relief stay was developed for anchoring the blue ribbon and the cable anchor. The design of the strain relief stay is closely based on the plastic divider (PZ). It is installed laterally into the anchor profile or a commercially available C-profile and can add several strain relief elements through the stay.



blue ribbon ZLB 24

The Blue Ribbon is a special ekd cable tie with a 24 mm wide cable mounting. The Blue Ribbon can be locked on the strain relief stay or the plastic divider (2mm, 4mm). Cables with diameters of 7 mm up to 35 mm can be fixed single or multiple (s-shaped) with the Blue Ribbon.

ZLB24
part no. 1142

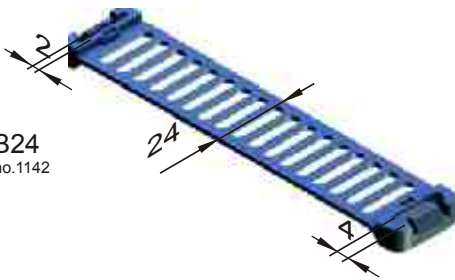

Ø7 < D < Ø35

cable anchor ZLA 8

Connect the lines with standard cable ties to the cable anchor (single or double slide) and push on the plastic divider.

A multi-layer connection of wires with this is as easy as possible, with the simple removal to carry out maintenance work.

ZLA8 4
part no. 1159

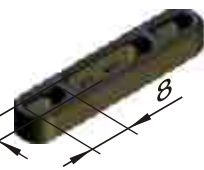

sliding anchor ZLS 10

The line is mounted with commercially available cable ties at the sliding anchor which is inserted into the aluminum C-profile. The simple movement of the sliding anchor provides a generous assembly space.

ZLS10
part no. 1160

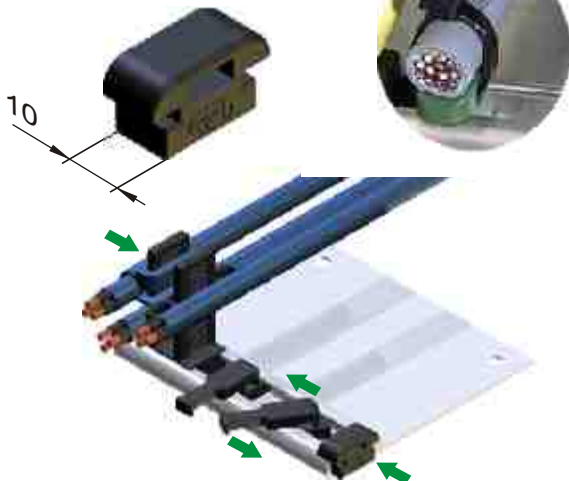

horn stay ZHS 10

The horn stay ZHS10 is transversely inserted into the anchor profile and locked by a 90 ° rotation. It is therefore permanently positioned in the anchor profile. The line is mounted with cable ties at the horn stay.

The horn stay HS 65 and HS 85 are components of the integrated strain relief for the rigid version of the chain series Kolibri. HS 55 and HS 75 are for the standard versions of the chain series Kolibri. For the series PKK the horn stay HS 220 and HS 320 deliverable.

The horn stays are attached to the stay of the chain connecting link.

ZHS10
part.no.1407

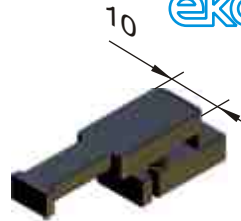

HS65
part.no.1503

HS85
part.no.1504

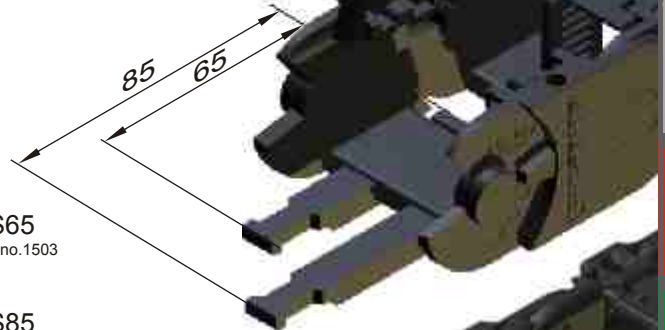

yoke clamps

Commercial yoke clamps can be used as a separate strain relief and are mounted with the aluminum C-profile of the SLE 520 or SLE 320 in front of the energy chain connectors.

As an integrated strain relief they are inserted directly into the first and last chain link of the SLE and PLE.

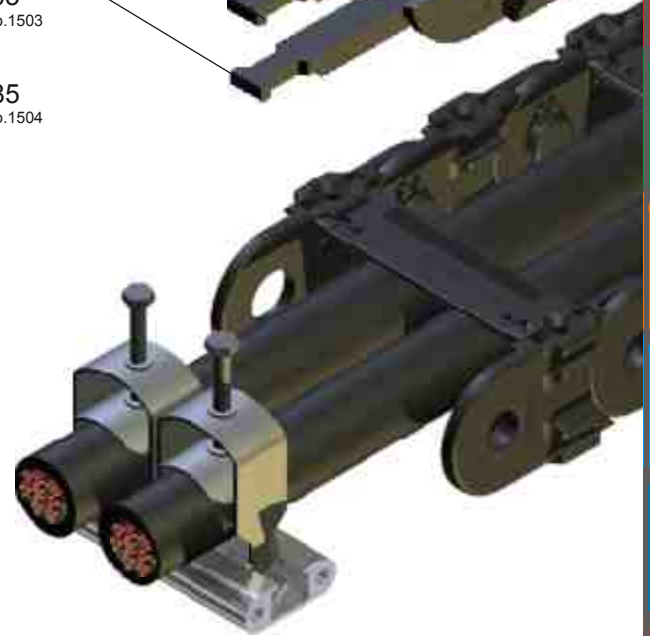

General operating and safety instructions

Energy chains are technical products which are designed and sized as part of an engineering-design according to a specific use. Dealing with this products in accordance with the generally recognized rules of operating and safety rules have to be followed in dealing with these products. Observe the accident prevention regulations. Additional requirements, such as when operating in hazardous areas are to take into account.

Proper use requires the observance of the dimension limits of the energy chains. The following experiences from practice shows errors can lead to significant functional impairment or damage of energy chains:

- Improper handling of the energy chain for transport and assembly due to weight load of the energy chain, especially an unsupported application.
- Contamination from such items as coarse shavings can cause damage to your lines.

If this can not be avoided in the operating in abrasive conditions such as abrasive dust entry or vibrations, so trough appropriate design and inspection intervals, particularly in unsupervised, automated operating systems to avoid unexpected machine failure.

The order for ekd energy chain includes the following information:

The energy chain selection is based on the diameter and number of cables to be laid. A clearance of at least 10% for cable and 20% for hoses should be available. The choice of plastic or steel energy chain, and between open and closed design and operating conditions.

The radius is also dependent on the cables to be installed. Comply with the specifications of the manufacturer. 10 times the largest line diameter can be a general rule.

The length of the chain depends on the travel distance. The following formula can be used:

$$L = \text{travel distance} / 2 + (4 \times \text{radius}) \text{ (round up to link pitch)}$$

Kolibri, PKK and PLE energy chains can be supplied with additional connector links (see figure below).

The width of the chain depends on the number and dimension of the cables to be installed. With slow applications cables can be installed on top of one another, creating extra space.

ekd plastic energy chains with integrated connectors need no additional connector parts. In case of special connector constitutions the order text lists first the fixed connector then the moving connector

The arrangement is only to be stated in special cases.

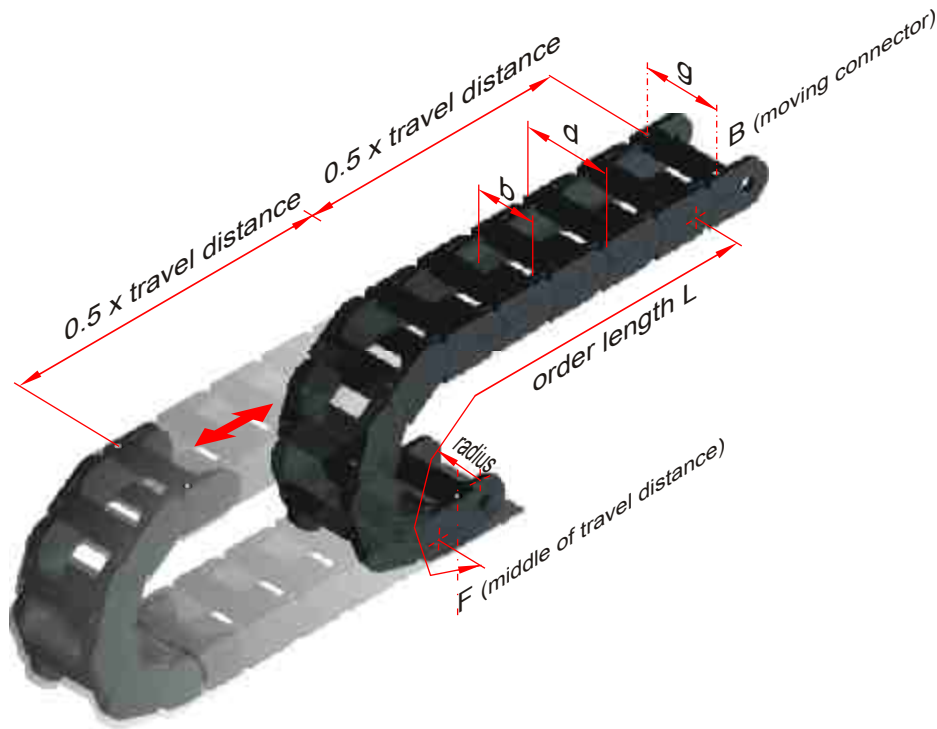

order examples:						
energy chain	/ radius	X length	/ width	/ connectors (F/B)	arrangement	stay distribution
Kolibri 30.095.0	/ 75	X 2170				
PKK 220	/ 200	X 2340	/ 200		"h"	;5 Pz, 1PT55
PLE 220	/ 200	X 2325	/ 200		"u"	;5 Pz, 1 Pt55
SLE 220	/ 200	X 2325	/ 200	- D/E		n.Z.
GKA 160	/ 1000	X 8775	/ 660	- D/E		n.Z.
SFK 32N	/ 250	X 3000		- A/N	"h"	
PFR 223	/ 200	X 3200		- K/K		

ORDER EXAMPLES

Kolibri 30.095.0 (standard type, pitch 35 mm), normal arrangement, bending radius R75, travel $s = 3.680$ m:

$$s/2 + 4R = 3.680\text{mm}/2 + (4 \times 75\text{mm}) = 2140\text{mm}$$

$$2140\text{mm}/35\text{mm} = 61.14 \Rightarrow 62 \text{ chain links}$$

$$62 \times 35\text{mm} = 2170\text{mm} = \text{order length } L$$

The energy chain is mounted via the integrated connector. An interior separation is not necessary.

order text:
pos 1: 1 pcs. Kolibri 30.095.0 / 75 x 2170

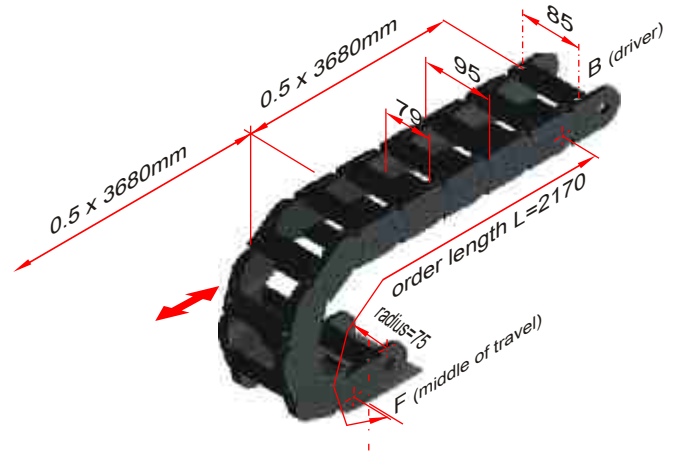

PKK 220 bending radius R200, travel 3.00m, inner width 200 mm (stay length 200), the chain is assembled hanging, inner separation through 5 PZ (movable) and 1 PT 55 in every 2. chain link.

A strain relief of the lines has to be installed bilateral with anchor profile, strain relief stays, cable anchors and sliding anchors.

$$s/2 + 4R = 3.000\text{mm}/2 + (4 \times 200\text{mm}) = 2300\text{mm}$$

$$2300\text{mm}/65\text{mm} = 35.38 \Rightarrow 36 \text{ chain links}$$

$$36 \times 65\text{mm} = 2340\text{mm} = \text{order length } L$$

order text:
pos.1: 1 pcs. PKK 220 / 200 x 2340 / 200 "h"; 5 PZ (movable), 1PT55, in every 2.link
pos.2: 2 pcs. ZLP 230 mit 7 ZLS 10, 2 ZL50, 2 ZLA 8

separation:

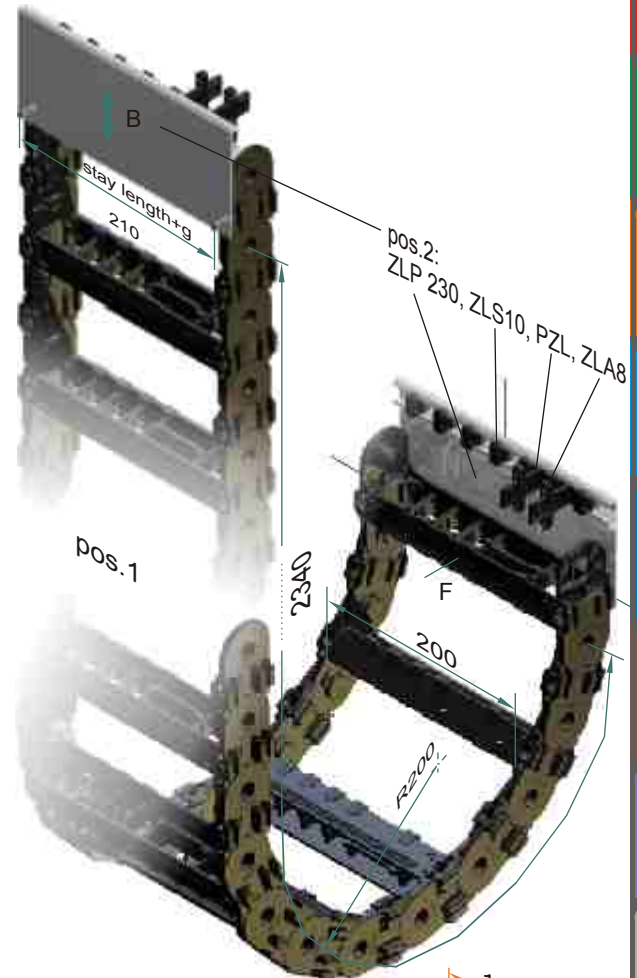
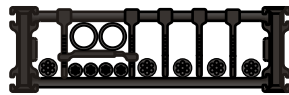

PLE 320 bending radius R100, travel 1.00m, inner width 100 mm (stay length 100), bottom driver, plastic inserts according to drawing no. xy in every chain link. A strain relief should be installed by the customer

$$s/2 + 4r = 1.000\text{mm}/2 + (4 \times 100\text{mm}) = 900\text{mm}$$

$$900\text{mm}/100\text{mm} = 9 \Rightarrow 9 \text{ chain links}$$

$$9 \times 100\text{mm} = 900\text{mm} = \text{order length } L$$

order text:
PLE 320 / 100 x 900 / 100 "u"; inserts acc. dwg. no.xy

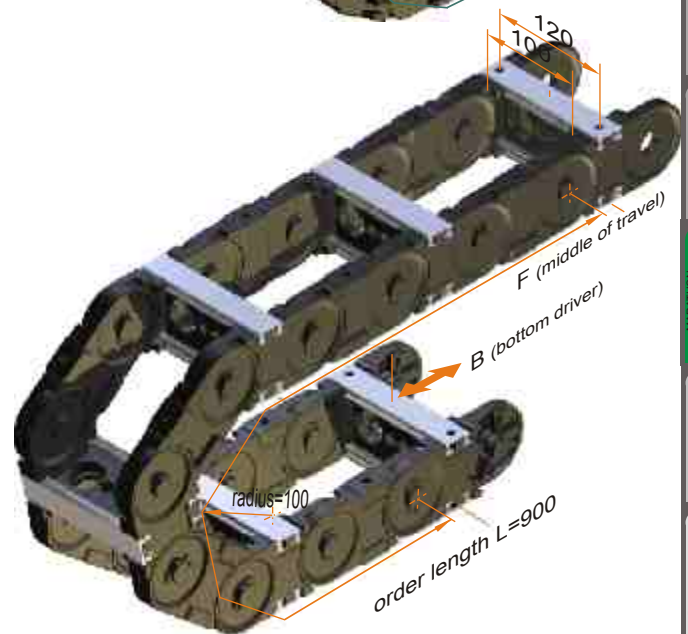

ORDER EXAMPLES

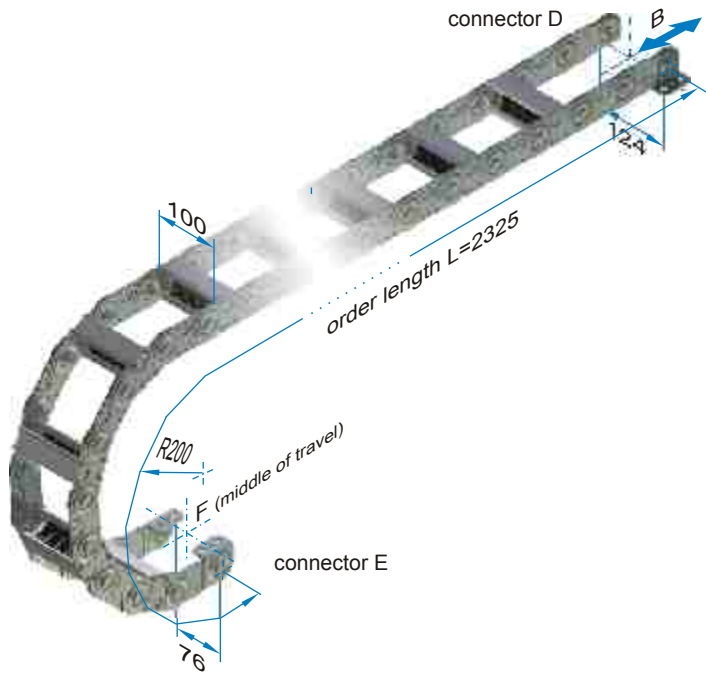

SLP 220 (SLE standard type with plastic inserts), pitch 75 mm, bending radius R200, travel $s = 3.00\text{m}$, inner width (=stay length) 100 mm, normal arrangement. The energy chain is mounted via connector D and E. A separation is done by 5 PZ in every second chain link:

$$S/2+4R = 3.000\text{mm}/2 + (4 \times 200\text{mm}) = 2300\text{mm}$$

$$2300\text{mm}/75\text{mm} = 30.66 \Rightarrow 31 \text{ chain links}$$

$$31 \times 75\text{mm} = 2325\text{mm} = \text{order length } L$$

order text:

pos 1: 1 pcs. SLP220/200x2325/100-E/D;5 PZ

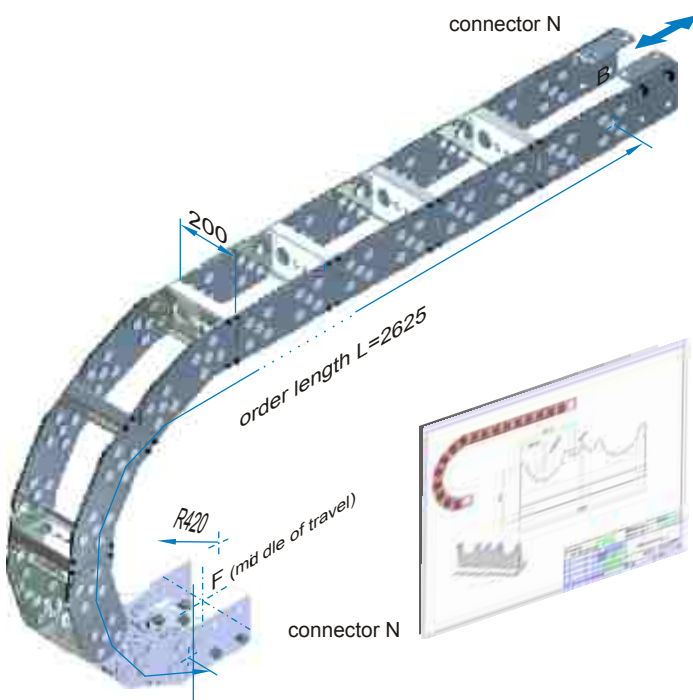

GKA 110 (GKA standard type with aluminium stays), pitch 175 mm, bending radius R420 (minimum polygon), travel $s = 1.80\text{ m}$, inner width (=stay length) 200 mm, normal arrangement.

The chain is mounted on both sides with connector N (connector N). Separation and adapted bending radius are according to drawing.

$$S/2+4R = 1800\text{mm}/2 + (4 \times 420\text{mm}) = 2580\text{mm}$$

$$2580\text{mm}/175\text{mm} = 14.74 \Rightarrow 15 \text{ chain links}$$

$$15 \times 175\text{mm} = 2625\text{mm} = \text{order length } L$$

order text:

pos 1: 1 pcs. GKA 110 /420x2625/200-N/N
according to dwg. no. 0000/2009

For energy chains type GKA choose the order length as uneven multiple of the pitch.

ORDER EXAMPLES

SFK 22H, bending radius R150, travel s = 3.00m, inner width 80 mm, inner height 56 mm, normal arrangement.
The energy chain is mounted with connector N on both ends.

$$S/2+4R = 3.000\text{mm}/2+(4 \times 150\text{mm}) = 2100\text{mm}$$

$$2100\text{mm} = \text{order length L}$$

order text:
pos 1: 1 pcs. SFK 22H/150x2100-N/N

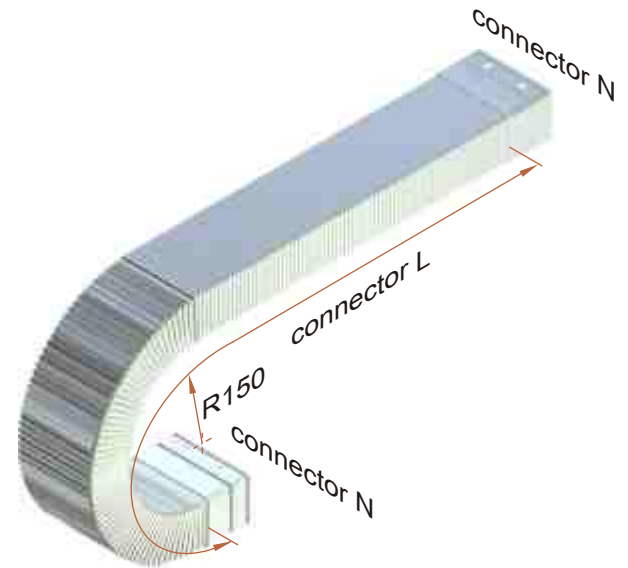

PFR 122, pitch 35 mm, bending radius R75mm, travel s = 0.31 m, inner width 38 mm, inner height 50 mm, normal arrangement.

The carrier is mounted via connector A and connector B.

$$S/2+4R = 310\text{mm}/2+(4 \times 75\text{mm}) = 455\text{mm}$$

$$455\text{mm}/35\text{mm} = 13 \text{ chain links}$$

$$13 \times 75\text{mm} = 455\text{mm} = \text{order length L}$$

order text:
pos 1: 1 pcs. PFR 122/75x455-A/B

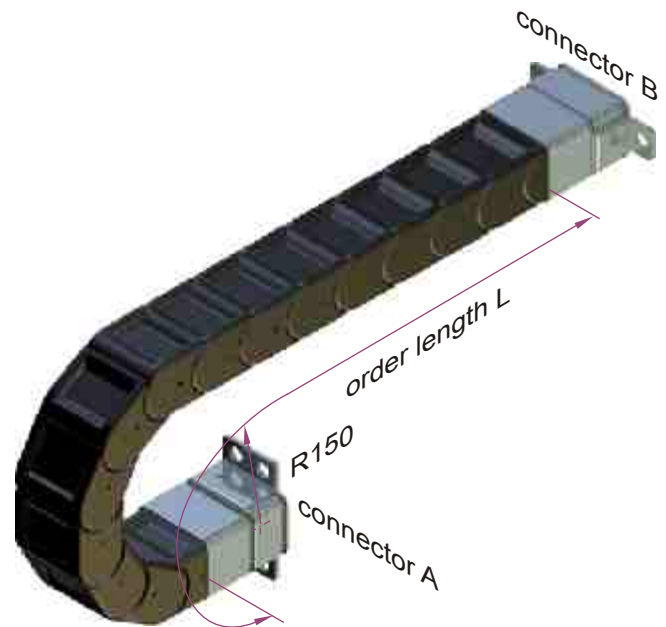

Kolibri 40.062.0 ELTOLA, pitch 45 mm, bending radius R100, travel s = 0.64 m, normal arrangement.
The chain is mounted via the integrated connectors.

$$S/2+4R = 640\text{mm}/2+(4 \times 100\text{mm}) = 720 \text{ mm}$$

$$720\text{mm}/45\text{mm} = 16 \text{ chain links}$$

$$720\text{mm} = \text{order length L}$$

order text:
pos 1: 1 pcs. Kolibri 40.062.0/100x720 ELTOLA

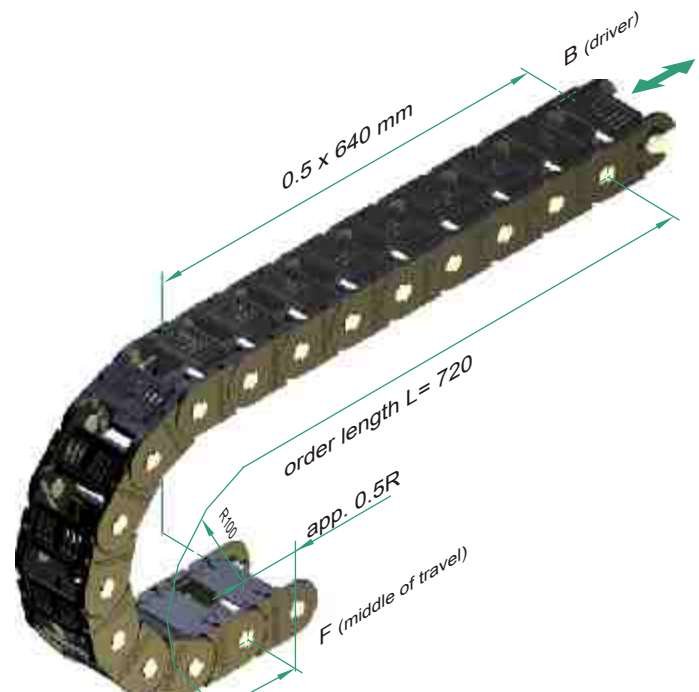

Kolibri

- Kolibri applications 19
- Kolibri dimensions 20
- Kolibri types 21
- Kolibri sizes 22
- Kolibri height 10 23
- Kolibri height 15 24
- Kolibri height 22 26
- Kolibri height 30 28
- Kolibri height 40 33
- Kolibri height 50 35
- Kolibri height 65 37
- Kolibri parts 39
- Kolibri assembly 40
- Kolibri flange connect. 42
- Kolibri part numbers 44



closed + open

The inexpensive energy chain for light-weight applications. The patented opening offers high rigid torsion behaviour and comfortable handling in one.

- easy access by flap stays
- extremely rigid and wear resistant
- unique separation with the pinch stay
- smallest dimensions

All ekd plastic energy chains are equipped with integrated connectors. Additional mounting parts are not needed.

Dimensions

bending radii:	15	to	300 mm
inner height:	7	to	50 mm
inner width:	7	to	205 mm
weight:	0.06	to	2.7 kg/m

Travel distance

The maximum travel distance is given by the arrangement and the load (weight of the lines). At normal arrangements the maximum travel distance is double the free carrying length. Support rollers or similar equipment may exceed this value.

In gliding arrangements travel distances up to 100 m are possible (according to the application).

For longer travels see chapter on design guidelines.

Travel speed

There are no limits for the travel speed in general. But with gliding arrangements application specific influences have to be taken into account.

Acceleration

There are no limits for the accelerations, in general. Limits may occur through the tensile stresses at high line weights.

Temperature

Long term temperature limits are between -20°C and 100°C.

Special variants

ELTOLA	... silent running
ALLROUND	... all movements
ATEX	... EX-protection
ESD	... antistatic
V-0	... self extinguishing

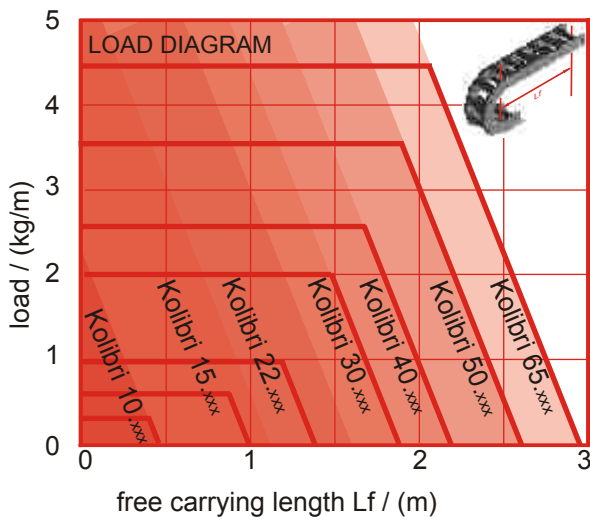

APPLICATION AREAS

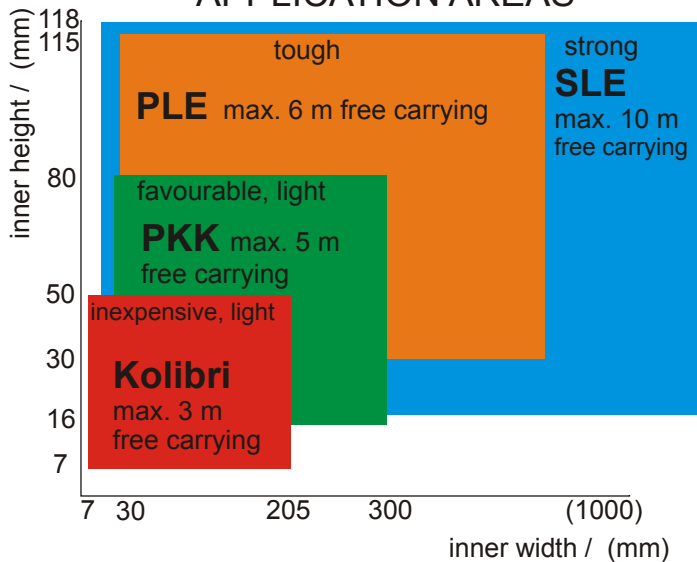

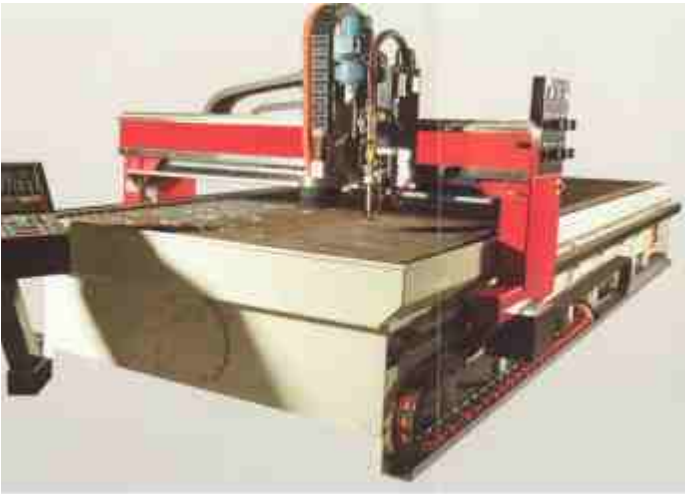

robotics, handling,
transportation, paper production,
textile industries, water plants



Content

Design guidelines

Order infos

Kolibri

PKK

PLE

SLE

GKA

SFK

PFR

Troughs

Systems

MATERIALS
ALU
ROUN
ETOLA

Materials

Informations

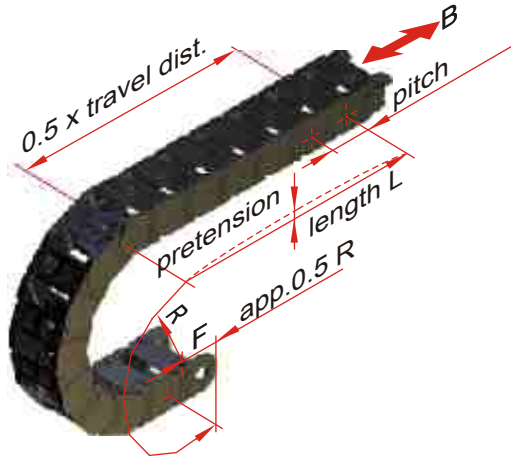
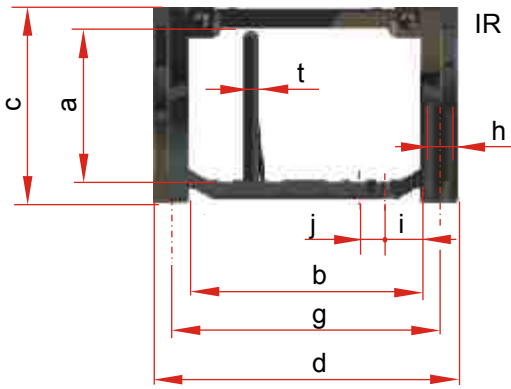

Kolibri c . d .type	prev. name		pitch	dimensions								weight kg/m
				a	b	c	d	g	h	i ¹⁾	j ¹⁾	
10.012.4	00.3		15	Ø7	10	12	12	3	-	-	-	0.05
15.015.3	.4	0	0.3	20	Ø10	15	15	15	4	-	-	0.15
15.036.5		02.5		18	10	25	15	36	30	4	-	0.30
15.037.3		02		20	10	24	15	37	30	4	-	0.30
15.051.0		03		20	10	39	15	51	44	4	-	0.35
22.025.4		04.3		30	17	15	22	25	19,4	4	-	0.20
22.038.0		05.0		26	17	27	22	38	32.5	4	8	0.34
22.048.0		06		30	17	36	22	48	41	4	13	0.37
22.060.5		07.5		26	16	48	22	60	54	4	9,5	0.54
30.030.3		1		40	24	18	30	30	23	4	-	0.50
30.050.0 .1	.5	10.0	10.5	35	23	34	30	50	40	5	9,5	0.54
30.060.0 .1		11.0		35	23	44	30	60	50	5	9,5	0.61
30.080.0 .1 .2 .4 .5		12.0	12.5	35	23	64	30	80	70	5	9,5	0.65
30.095.0 .1		13.0		35	23	79	30	95	85	5	12	0.75
30.125.0 .1		14.0		35	23	109	30	125	115	5	12	0.87
40.062.2	.5	15.5		45	31	48	40	62	54	5	8	0.91
40.075.2				45	31	60	40	75	67	5	8	1.05
50.065.0	.5	21.0	21.5	55	40	48	50	65	55	6	9	1.30
50.095.0 .1 .2 .5		19.0	19.5	55	40	78	50	95	85	6	6,5	1.35
50.125.0		22.0		55	40	108	50	125	115	6	6,5	1.52
50.150.0 .1	.5	20.0	20.5	55	40	133	50	150	140	6	6,5	1.90
65.095.1	.5	24.5		70	50	77	65	95	85	6	13,5	2.20
65.135.1	.5	25.5		70	50	117	65	135	125	6	13,5	2.60
65.195.1	.5	27.5		70	50	177	65	195	185	6	13,5	3.00
65.225.0		29.0		70	50	205	65	225	215	6	17,5	2.71

1) not Kolibri *.2

2) for Kolibri *.2 is t=4 for Kolibri *.5 is t=2

Kolibri 00.000.0

standard type
flap open bars in inner radius
separable with pinch stay
integrated connector



Kolibri 00.000.1

openable in outer radius
flap open bars in outer radius
separable with pinch stay
integrated connector



Kolibri 00.000.2

rigid version
flap open bars in inner radius
separable with PZ
integrated connector



Kolibri 00.000.3

one part chain links
not openable
not separable
integrated connector



Kolibri 00.000.4

film stay
film stay in inner radius
not separable
(integrated connector)



Kolibri 00.000.5

closed type
flap open covers in outer radius
separable with pinch stay
integrated connector



Kolibri	c . d .type		prev. name	radius								
10.012.4			00.3		15	30	50					
15.015.3	.4		0	0.3	17,5 ²⁾	20	30					
15.036.5				02.5		30	50					
15.037.3			02			20						
15.051.0			03			20	30					
22.025.4			04.3			35	70	100				
22.038.0			05.0			35	50	70	100			
22.048.0			06			35	70					
22.060.5				07.5		50	70	100				
30.030.3			1			40		100			200	
30.050.0	.1	.5	10.0	10.5		40 ¹⁾	60	75	100	150	200	
30.060.0	.1		11.0			40	50	75	100	150	200	
30.080.0	.1	.2 .4 .5	12.0	12.5		40 ¹⁾	60 ⁴⁾	75	100	150	200	
30.095.0	.1		13.0			40	75	100	125	150	200	
30.125.0	.1		14.0			40	75	100	150	200		
40.062	.2	.5	15.0	15.5		60 ¹⁾	75	100	150	200		
40.075.2			16.0			60	75	100	150	200		
50.065.0	.5		21.0	21.5		75 ¹⁾	100	125 ¹⁾	150	200	250	
50.095.0	.1	.2 .5	19.0	19.5		75 ¹⁾	100	125 ¹⁾	150	175 ¹⁾	200	250
50.125.0			22.0			75	100	150	200	250		
50.150.0	.5		20.0	20.5		75 ¹⁾	100	150	200	250		
65.095.1	.5		24.1	24.5				125	150	200	300	
65.135.1	.5			25.5				125	150	200	300 ³⁾	
65.195.1	.5			27.5				125	150	200	300	
65.225.0			29.0					100	125	150	200	300

1) not Kolibri xx.xxx.5

2) only Kolibri 15.015.3

3) additional R400

4) only Kolibri 30.080.5



Kolibri HEIGHT 10

inner height 7, inner width 7



Kolibri 10.012.4

one part link
film stay in inner radius
integrated connector or separate connectors
space (axb): $\varnothing 7$ not separable
bend radius: 15 / 30 / 50
weight: 0,05 kg/m
free carrying length: 0.4 m at 0.3 kg/m load
pitch: 15

order example:

Kolibri 10.012.4 / 50 x 1005

type / radius x length





Kolibri HEIGHT 15

inner height 10, inner width 10 to 39

Kolibri 15.015.3

one part chain link
not openable
connector as separate part (*part.no. 0700*)
space (axb): $\varnothing 10$ not separable
bend radius: 17.5 / 20 / 30
weight: 0.15 kg/m
free carrying length: 0,9.m at 0.9 kg/m load
pitch: 20

order example:

Kolibri 15.015.3 / 30 x 1000

type / radius x length



Kolibri 15.015.4

one part chain link
film-stay in inner radius
connector as separate part (see Kolibri 15.015.3)
space (axb): $\varnothing 10$ not separable
bend radius: 20 / 30
weight: 0.15 kg/m
free carrying length: 0.9 m at 0.9 kg/m load
pitch: 20

order example:

Kolibri 15.015.4 / 30 x 1000

type / radius x length

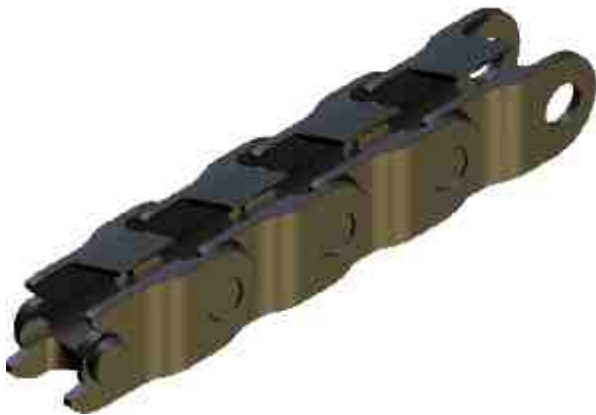

Kolibri 15.036.5

closed type
flap covers in outer radius
integrated connectors
space (axb): 10 x 25 not separable
bend radius: 30 / 50
weight: 0.3 kg/m
free carrying length: 0.9m at 0.9 kg/m load
pitch: 18

order example:

Kolibri 15.036.5 / 30 x 1008

type / radius x length



Kolibri HEIGHT 15

inner height 10, inner width 10 to 39



Kolibri 15.037.3

one part chain link
not openable
integrated connectors

space (axb): 10 x 24 not separable
bend radius: 20, 30
weight: 0.3 kg/m
free carrying length: 0.9 at 0.9 kg/m load
pitch: 20

order example:

Kolibri 15.037.3 / 20 x 1000

type / radius x length



Kolibri 15.051.0

standard type
flap stay in inner radius
integrated connectors

space (axb): 10 x 39 not separable
bend radius: 20 / 30
weight: 0.35 kg/m
free carrying length: 0.9 m at 0.9 kg/m load
pitch: 20

order example:

Kolibri 15.051.0 / 30 x 1000

type / radius x length





Kolibri HEIGHT 22

inner height 16 to 22, inner width 15 to 48



Kolibri 22.025.4

one part chain link
film stay
integrated connectors

space (axb): **17 x 15 not separable**
bend radius: 35 / 70 / 100
weight: 0.20 kg/m
free carrying length: 1.3 m at 1.5 kg/m load
pitch: 30

order example:

Kolibri 22.025.4 / 35 x 1020

type / radius x length

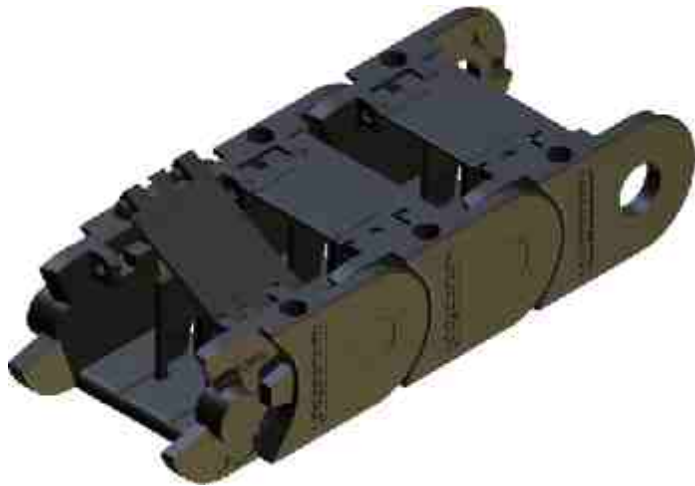

Kolibri 22.038.0

standard type
flap stay in inner radius
integrated connectors

space (axb): **17 x 27 separable (PZ ANr.1688)**
bend radius: 35 / 50 / 70 / 100
weight: 0.34 kg/m
free carrying length: 1.5 m at 1.0 kg/m load
pitch: 26

order example:

Kolibri 22.038.0 / 35 x 1040

type / radius x length

Kolibri HEIGHT 22

inner height 16 to 22, inner width 15 to 48

max. 14-20

Kolibri 22.048.0

open type
flap stay in inner radius
integrated connectors

space (axb): 17 x 36 not separable
bend radius: 35 / 70
weight: 0.37 kg/m
free carrying length: 1.3 m at 1.5 kg/m load
pitch: 30

order example:

Kolibri 22.048.0 / 35 x 1200

type / radius x length



Kolibri 22.060.5

closed type
flap stay in outer radius
integrated connectors

space (axb): 16 x 48 separable (PZ ANr.1294)
bend radius: 50 / 70 / 100
weight: 0.54 kg/m
free carrying length: 1.3 m at 1.5 kg/m load
pitch: 26

order example:

Kolibri 22.060.5 / 100 x 1014

type / radius x length





Kolibri HEIGHT 30

inner height 23 to 24, inner width 18 to 109

Kolibri 30.030.3

one part chain link
not openable
integrated connectors

space (axb): **24 x 18 not separable**
bend radius: 40 / 100 / 200
weight: 0.50 kg/m
free carrying length: 1.5 m at 2.0 kg/m load
pitch: 40

order example:

Kolibri 30.030.0 / 100 x 1200

type / radius x length



Kolibri 30.050.0

standard type
flap stay in inner radius
integrated connectors

space (axb): **23 x 34 separable (PZ ANr.1258)**
bend radius: 40 / 60 / 75 / 100 / 150 / 200
weight: 0.54 kg/m
free carrying length: 1.5 m at 2.0 kg/m load
pitch: 35

order example:

Kolibri 30.050.0 / 100 x 1225

type / radius x length

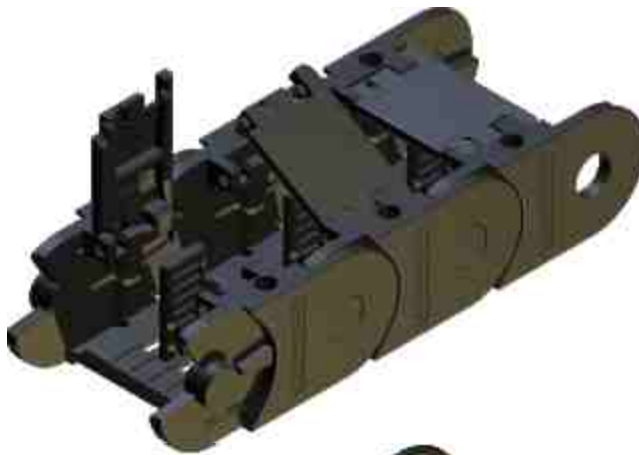

Kolibri 30.050.1

open type
flap stay in outer radius
integrated connectors

space (axb): **23 x 34 separable (PZ ANr.1258)**
bend radius: 40 / 60 / 75 / 100 / 150 / 200
weight: 0.54 kg/m
free carrying length: 1.5 m at 2.0 kg/m load
pitch: 35

order example:

Kolibri 30.050.1 / 100 x 1225

type / radius x length

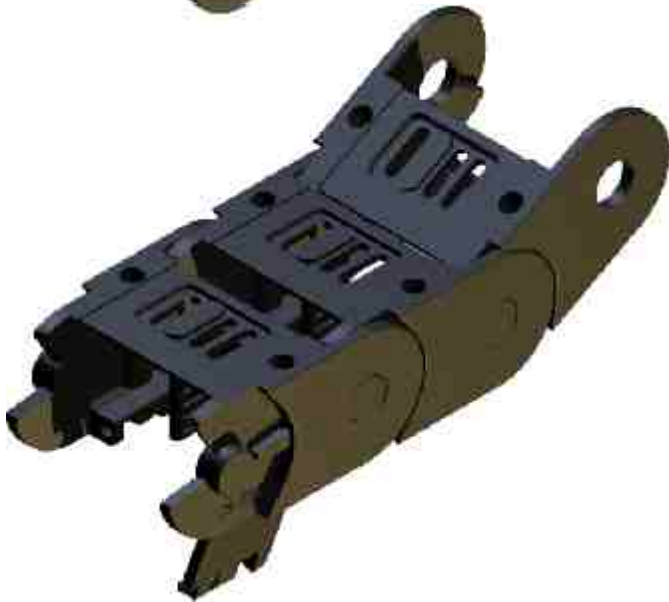

Kolibri 30.050.5

closed type
flap covers in outer radius
integrated connectors

space (axb): **23 x 34 separable (PZ ANr.1017)**
bend radius: 60 / 75 / 100 / 150 / 200
weight: 0.58 kg/m
free carrying length: 1.5 m at 2.0 kg/m load
pitch: 35

order example:

Kolibri 30.050.5 / 100 x 1225

type / radius x length



Kolibri HEIGHT 30

inner height 23 to 24, inner width 18 to 109



Kolibri 30.060.0

standard type
flap stay in inner radius
integrated connectors

space (axb): 23 x 44 separable (PZ ANr.1258)
bend radius: 40 / 50 / 75 / 100 / 150 / 200
weight: 0.61 kg/m
free carrying length: 1.5 m at 2.0 kg/m load
pitch: 35

order example:

Kolibri 30.060.0 / 100 x 1225

type / radius x length

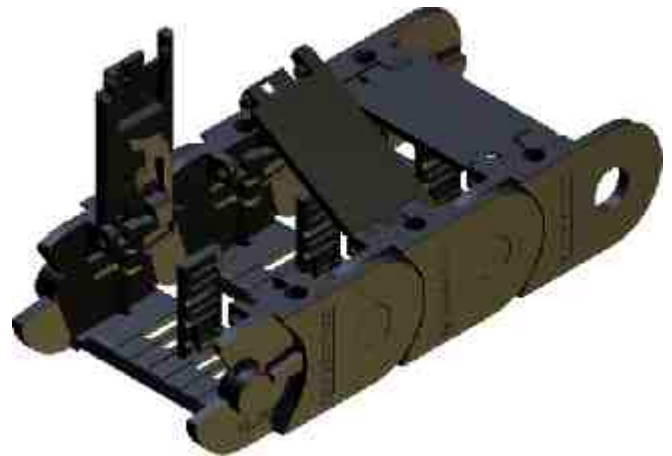

Kolibri 30.060.1

open type
flap stay in outer radius
integrated connectors

space (axb): 23 x 44 separable (PZ ANr.1258)
bend radius: 40 / 50 / 75 / 100 / 150 / 200
weight: 0.61 kg/m
free carrying length: 1.5 m at 2.0 kg/m load
pitch: 35

order example:

Kolibri 30.060.1 / 100 x 1225

type / radius x length

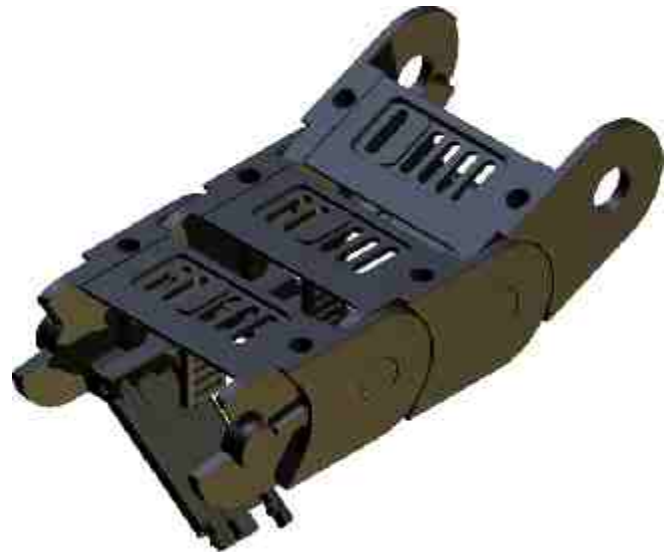

Kolibri 30.080.0

standard type
flap stay in inner radius
integrated connectors

space (axb): 23 x 64 separable (PZ ANr.1258)
bend radius: 40 / 50 / 75 / 100 / 150 / 200
weight: 0.65 kg/m
free carrying length: 1.5 m at 2.0 kg/m load
pitch: 35

order example:

Kolibri 30.080.0 / 100 x 1225

type / radius x length

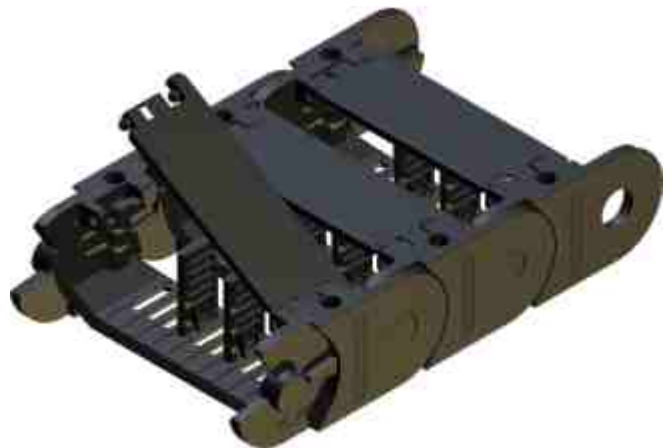

Kolibri 30.080.1

open type
flap stay in inner radius
integrated connectors

space (axb): 23 x 64 separable (PZ ANr.1258)
bend radius: 40 / 50 / 75 / 100 / 150 / 200
weight: 0.65 kg/m
free carrying length: 1.5 m at 2.0 kg/m load
pitch: 35

order example:

Kolibri 30.080.1 / 100 x 1225

type / radius x length

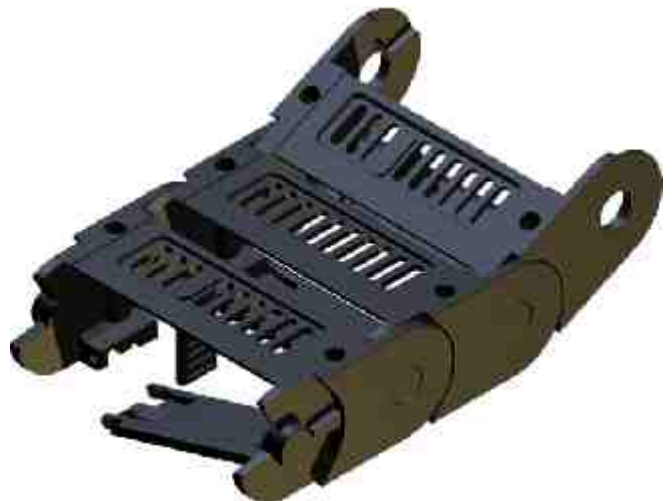



Kolibri HEIGHT 30

inner height 23 to 24, inner width 18 to 109

Kolibri 30.080.2

rigid type
flap stay in inner radius
integrated connectors

space (axb): **21 x 64 not separable**
bend radius: 40 / 75 / 100 / 150 / 200
weight: 0.7 kg/m
free carrying length: 1.5 m at 2.0 kg/m load
pitch: 35

order example:

Kolibri 30.080.2 / 100 x 1225

type / radius x length

Kolibri 30.080.4

one part chain link
lining without assembly
integrated connectors

space (axb): **21 x 64 not separable**
bend radius: 40 / 75 / 100 / 150 / 200
weight: 0.65 kg/m
free carrying length: 1.5 m at 2.0 kg/m load
pitch: 35

order example:

Kolibri 30.080.4 / 100 x 1225

type / radius x length

Kolibri 30.080.5

closed type
flap covers in outer radius
integrated connectors

space (axb): **23 x 64 separable (PZ ANr.1017)**
bend radius: 60 / 75 / 100 / 150 / 200
weight: 0.7 kg/m
free carrying length: 1.5 m at 2.0 kg/m load
pitch: 35

order example:

Kolibri 30.080.5 / 100 x 1225

type / radius x length



Kolibri HEIGHT 30

inner height 23 to 24, inner width 18 to 109



Kolibri 30.095.0

standard type
flap stays in inner radius
integrated connectors

space (axb): 23 x 79 separable (PZ ANr.1258)
bend radius: 40 / 75 / 100 / 125 / 150 / 200
weight: 0.75 kg/m
free carrying length: 1.5 m at 2.0 kg/m load
pitch: 35

order example:

Kolibri 30.095.0 / 100 x 1225

type / radius x length

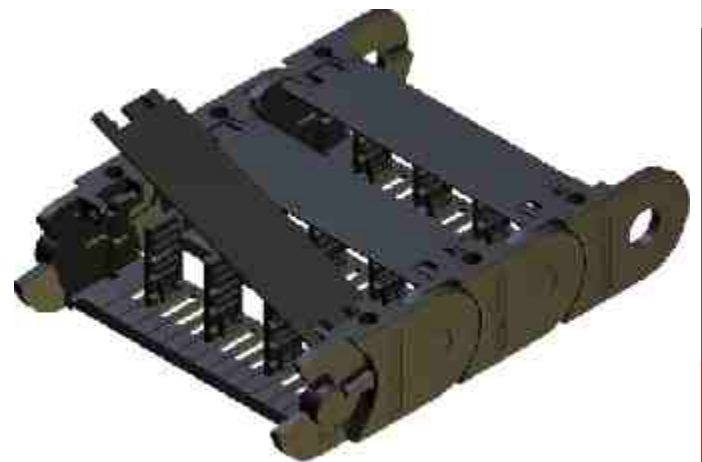

Kolibri 30.095.1

open type
flap stays in outer radius
integrated connectors

space (axb): 23 x 79 separable (PZ ANr.1258)
bend radius: 40 / 75 / 100 / 125 / 150 / 200
weight: 0.75 kg/m
free carrying length: 1.5 m at 2.0 kg/m load
pitch: 35

order example:

Kolibri 30.095.1 / 100 x 1225

type / radius x length





Kolibri HEIGHT 30

inner height 23 to 24, inner width 18 to 109

Kolibri 30.125.0

standard type
flap stay in inner radius
integrated connectors

space (axb): 23 x 109 separable (PZ ANr.1258)
bend radius: 40 / 75 / 100 / 150 / 200
weight: 0.87 kg/m
free carrying: 1.5 m at 2.0 kg/m load
pitch: 35

order example:

Kolibri 30.125.0 / 100 x 1225

type / radius x length

Kolibri 30.125.1

open type
flap stay in outer radius
integrated connectors

space (axb): 23 x 109 separable (PZ ANr.1258)
bend radius: 40 / 75 / 100 / 150 / 200
weight: 0.87 kg/m
free carrying: 1.5 m at 2.0 kg/m load
pitch: 35

order example:

Kolibri 30.125.1 / 100 x 1225

type / radius x length



Kolibri HEIGHT 40

inner height 31, inner width 48 to 60



Kolibri 40.062.2

rigid type
flap stay in inner radius
integrated connectors

space (axb): 31 x 48 separable ((PZ ANr.1521))
bend radius: 60 / 75 / 100 / 150 / 200
weight: 0.91 kg/m
free carrying length: 2.0 m at 1.0 kg/m load
pitch: 45

order example:

Kolibri 40.062.2 / 100 x 1260

type / radius x length

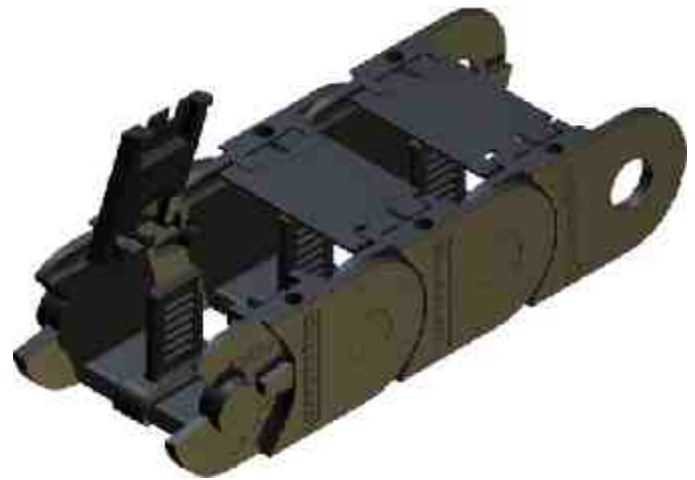

Kolibri 40.062.5

closed type
flap covers in outer radius
integrated connectors

space (axb): 31 x 48 separable ((PZ ANr.1268))
bend radius: 75 / 100 / 150 / 200
weight: 0.93 kg/m
free carrying length: 2.0 m at 1.0 kg/m load
pitch: 45

order example:

Kolibri 40.062.5 / 100 x 1260

type / radius x length



max. 27 

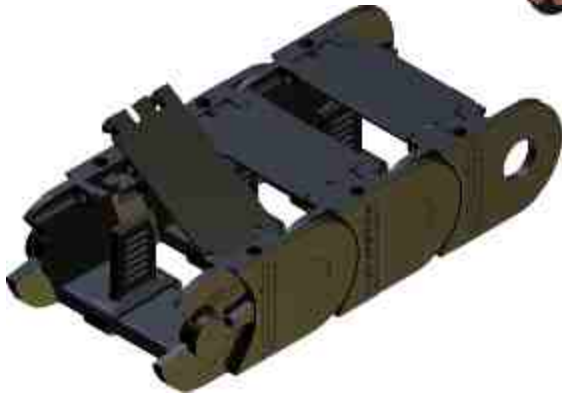

Kolibri HEIGHT 40

inner height 31, inner width 48 to 60

Kolibri 40.075.2

rigid type
flap stay in inner radius
integrated connectors

space (axb): 29 x 60 separable (PZ ANr.1521)
bend radius: 60 / 75 / 100 / 150 / 200
weight: 1.05 kg/m
free carrying length: 2.0 m at 1.0 kg/m load
pitch: 45

order example:

Kolibri 40.075.2 / 100 x 1260

type / radius x length

Kolibri HEIGHT 50

inner height 38 to 40, inner width 48 to 134



Kolibri 50.065.0

standard type
flap stay in inner radius
integrated connectors

space (axb): 40 x 48 separable (PZ ANr.1113)
bend radius: 75 / 100 / 125 / 150 / 200 / 250
weight: 1.30 kg/m
free carrying: 2.4 m at 1.0 kg/m load
pitch: 55

order example:

Kolibri 50.065.0 / 100 x 1265

type / radius x length



Kolibri 50.065.5

colsed type
flap covers in outer radius
integrated connectors

space (axb): 40 x 48 separable (PZ ANr.1113)
bend radius: 100 / 150 / 200 / 250
weight: 1.30 kg/m
free carrying length: 2.4 m at 1.0 kg/m load
pitch: 55

order example:

Kolibri 50.065.5 / 100 x 1265

type / radius x length



Kolibri 50.095.0 50.095.1

standard type
flap stay in inner radius flap stay in outer radius
integrated connectors

space (axb): 40 x 78 separable (PZ ANr.1113)
bend radius: 75/100/ 125/ 150/ 175/ 200/ 250
weight: 1.35 kg/m
free carrying length: 2.4 m at 1.0 kg/m load
pitch: 55

order example:

Kolibri 50.095.0 / 100 x 1265

type / radius x length

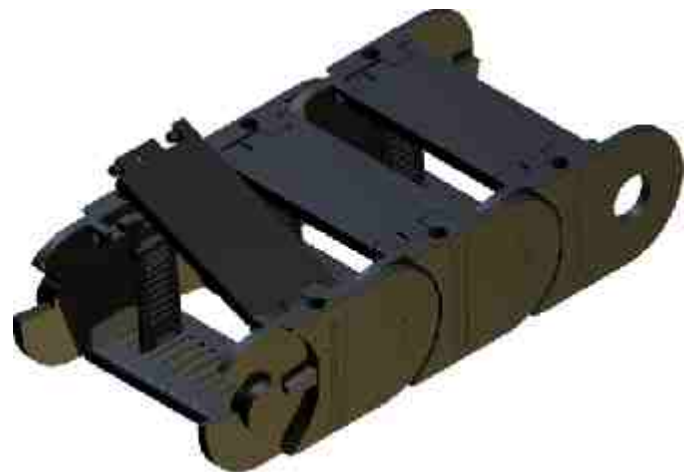

Kolibri 50.095.2

rigid type
flap stay in inner radius
integrated connectors

space (axb): 38 x 78 separable (PZ ANr.1451)
bend radius: 75/100/ 125/ 150/ 175/ 200/ 250
weight: 1.40 kg/m
free carrying length: 2.4 m at 1.0 kg/m load
pitch: 55

order example:

Kolibri 50.095.2 / 100 x 1265

type / radius x length

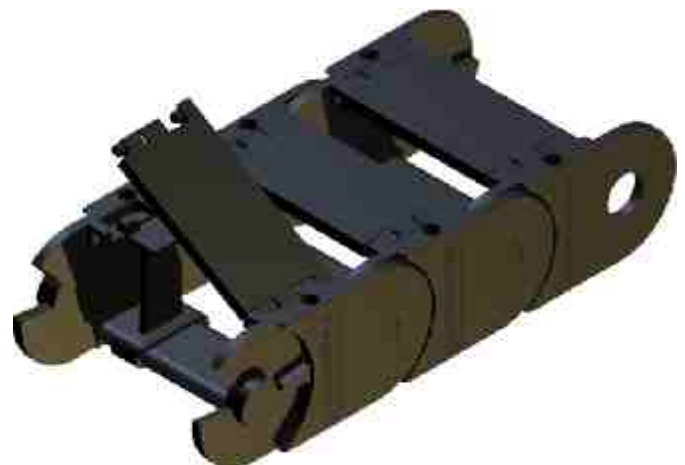

Kolibri HEIGHT 50

inner height 38 to 40, inner width 48 to 134

Kolibri 50.095.5

closed type
flap stay in outer radius
integrated connectors
space (axb): 40 x 78 separable (PZ ANr.1113)
bend radius: 75/100/ 125/ 150/ 175/ 200/ 250
weight: 1.40 kg/m
free carrying length: 2.4 m at 1.0 kg/m load
pitch: 55

order example:

Kolibri 50.095.5 / 100 x 1265

type / radius x length

Kolibri 50.125.0

standard type
flap stay in inner radius
integrated connectors
space (axb): 40 x 108 separable (PZ ANr.1326)
bend radius: 75 / 100 / 150 / 200 / 250
weight: 1.52 kg/m
free carrying length: 2.4 m at 1.0 kg/m load
pitch: 55

order example:

Kolibri 50.125.0 / 100 x 1265

type / radius x length

Kolibri 50.150.0 50.150.1

standard type
flap stay in inner radius flap stay in outer radius
integrated connectors
space (axb): 40 x 133 separable (PZ ANr.1326)
bend radius: 75 / 100 / 150 / 200 / 250
weight: 1.90 kg/m
free carrying length: 2.4 m at 1.0 kg/m load
pitch: 55

order example:

Kolibri 50.150.0 / 100 x 1265

type / radius x length

Kolibri 50.150.5

closed type
flap stay in outer radius
integrated connectors
space (axb): 40 x 133 separable (PZ ANr.1113)
Bibend radius: 75 / 100 / 150 / 200 / 250
weight: 1.90 kg/m
free carrying length: 2.4 m at 1.0 kg/m load
pitch: 55

order example:

Kolibri 50.150.5 / 100 x 1265

type / radius x length

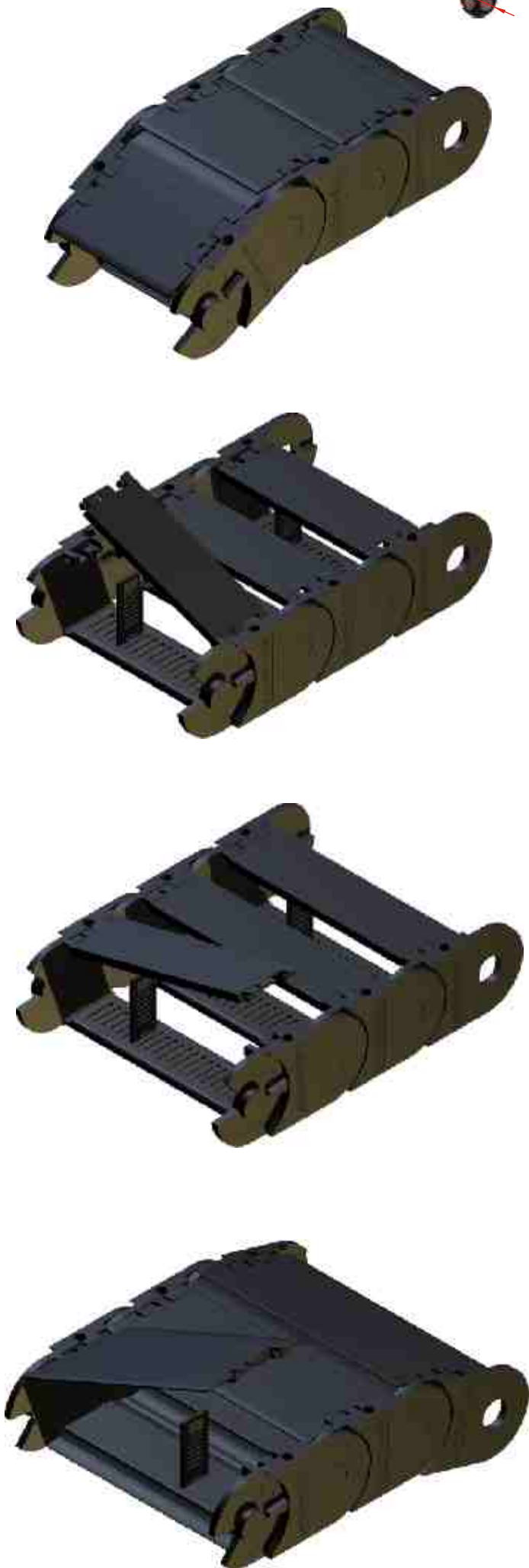

Kolibri HEIGHT 65

inner height 50, inner width 77 to 205



Kolibri 65.095.1

open type
flap stay in outer radius
integrated connectors

space (axb): 50 x 77 separable (PZ ANr.1129)
bend radius: 125 / 150 / 200 / 300
weight: 2.2 kg/m
free carrying length: 2.75 m at 1.0 kg/m load
pitch: 70

order example:

Kolibri 65.095.1 / 100 x 1400

type / radius x length



Kolibri 65.095.5

closed type
flap cover in outer radius
integrated connectors

space (axb): 50 x 77 separable (PZ ANr.1129)
bend radius: 125 / 150 / 200 / 300
weight: 2.2 kg/m
free carrying length: 2.75 m at 1.0 kg/m load
pitch: 70

order example:

Kolibri 65.095.5 / 100 x 1400

type / radius x length



Kolibri 65.135.1

open type
flap stay in outer radius
integrated connectors

space (axb): 50 x 117 separable (PZ ANr.1129)
bend radius: 125 / 150 / 200 / 300 / 400
weight: 2.6 kg/m
free carrying length: 2.75 m at 1.0 kg/m load
pitch: 70

order example:

Kolibri 65.135.1 / 100 x 1400

type / radius x length



Kolibri 65.135.5

closed type
flap cover in outer radius
integrated connectors

space (axb): 50 x 117 separable (PZ ANr.1129)
bend radius: 125 / 150 / 200 / 300 / 400
weight: 2.7 kg/m
free carrying length: 2.75 m at 1.0 kg/m load
pitch: 70

order example:

Kolibri 65.135.1 / 100 x 1400

type / radius x length



Kolibri HEIGHT 65

inner height 50, inner width 77 to 205



Kolibri 65.195.1

open type
flap stay in outer radius
integrated connectors
space (axb): **50 x 177 separable (PZ ANr.1129)**
bend radius: 125 / 150 / 200 / 300
weight: 2.9 kg/m
free carrying length: 2.75 m at 1.0 kg/m load
pitch: 70

order example:

Kolibri 65.195.1 / 100 x 1400

type / radius x length



Kolibri 65.195.5

closed type
flap cover in outer radius
integrated connectors
space (axb): **50 x 177 separable (PZ ANr.1129)**
bend radius: 125 / 150 / 200 / 300
weight: 3.0 kg/m
free carrying length: 2.75 m at 1.0 kg/m load
pitch: 70

order example:

Kolibri 65.195.5 / 100 x 1400

type / radius x length

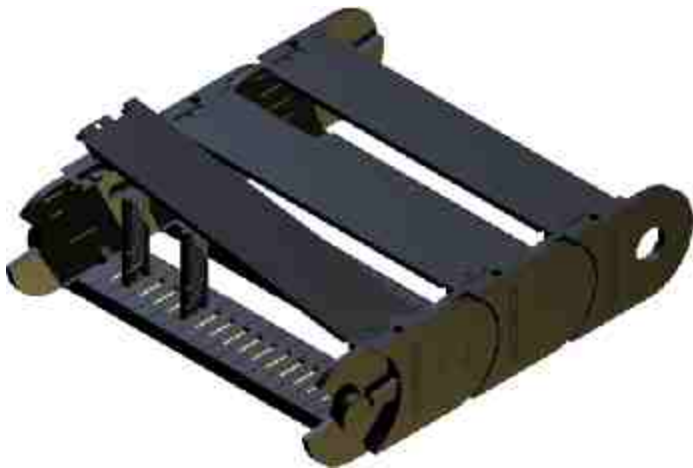

Kolibri 65.225.0

standard type
flap stay in inner radius
integrated connectors
space (axb): **50 x 205 separable (PZ ANr.1129)**
bend radius: 100 / 125 / 150 / 200 / 300
weight: 2.71 kg/m
free carrying: 2.75 m at 1.0 kg/m load
pitch: 70

order example:

Kolibri 65.225.0 / 100 x 1400

type / radius x length

- | Pos. | name |
|------|----------------------------------|
| 1 | link (open type) |
| 2 | link (closed type) |
| 3 | flange pivot |
| 4 | flange drilling |
| 5 | horn stay connector |
| 6 | horn stay 65 HS65 |
| 7 | horn stay 85 HS 85 |
| 8 | damping element |
| 9 | PZ (divider) |
| 10 | PZ (pinch stay) |
| 11 | flap stay |
| 12 | flap cover |
| 13 | notched horizontal divider |
| 14 | notched horiz. divider flying |
| 15 | telescopic horizontal divider |
| 16 | telescopic horiz. divider flying |
| 17 | ladderstay |
| 18 | hole-layer-stay 25 |
| 19 | hole-layer-stay 50 |

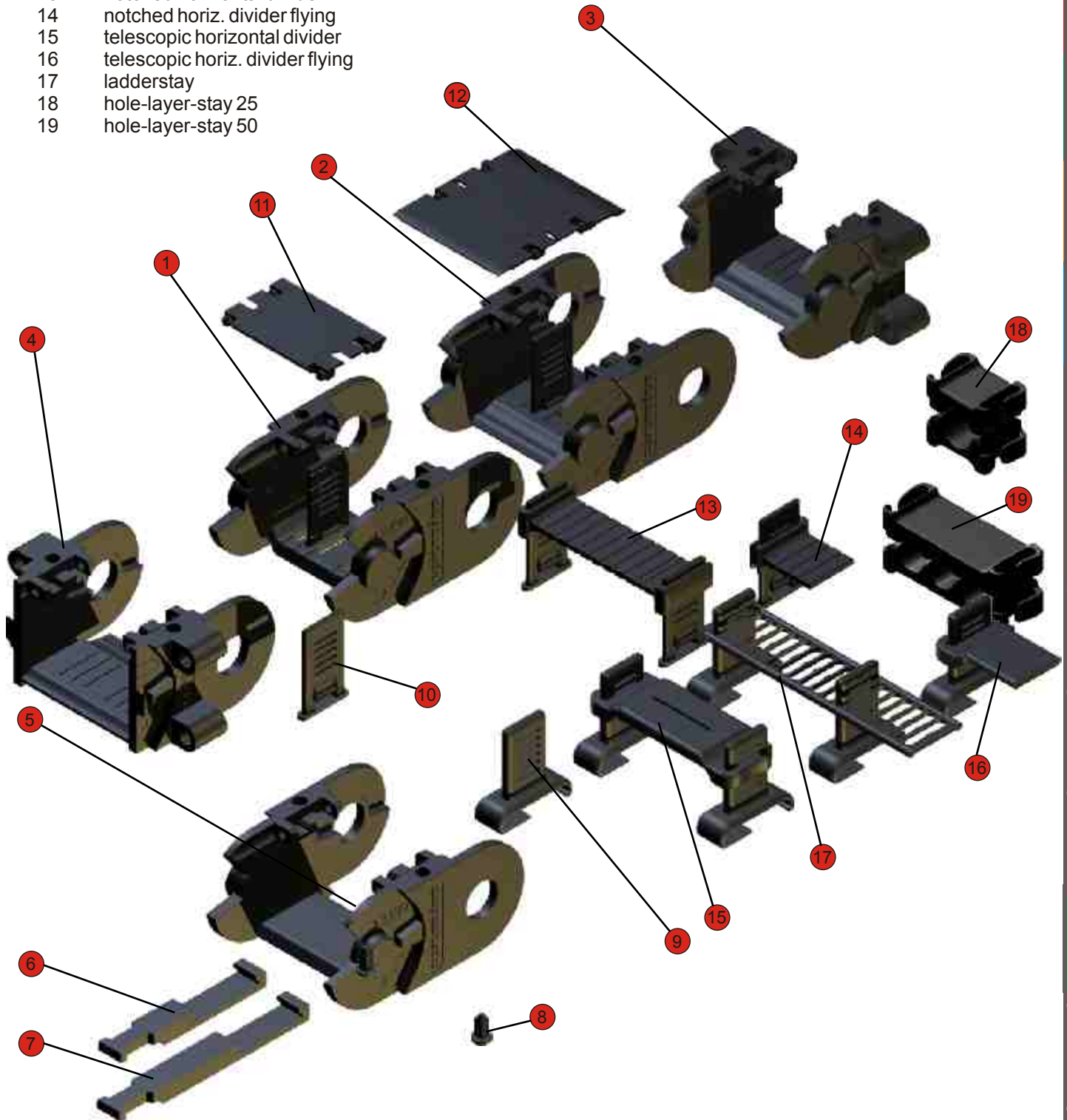

Opening and closing

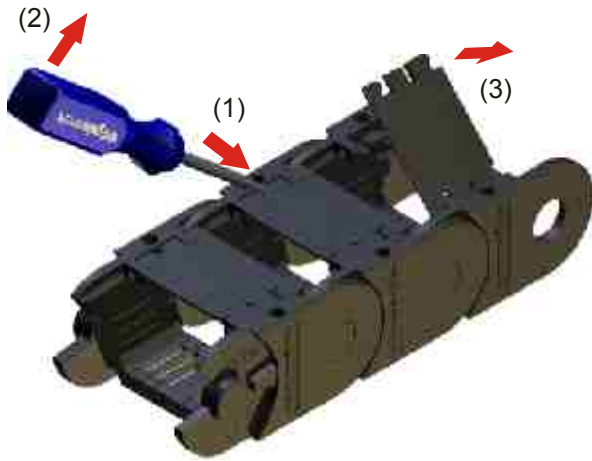

Push a screwdriver as shown in the the slot (1) then with a light lever movement (2) raise the tongue and push the locking pins of the flap stay (or the flap cover) out of the drilling. The flap stay can then be lifted (3). To remove the flap stay the second side has to be unlocked and the stay has to be pushed out against the direction of the cones.

The installation of the flap stays and flap covers are snapped in a slight angle with the pins against the corresponding drillings (4) and with slight pressure against the locking tongue.

Lifted flap stays can be re-engaged (5) with slight pressure.

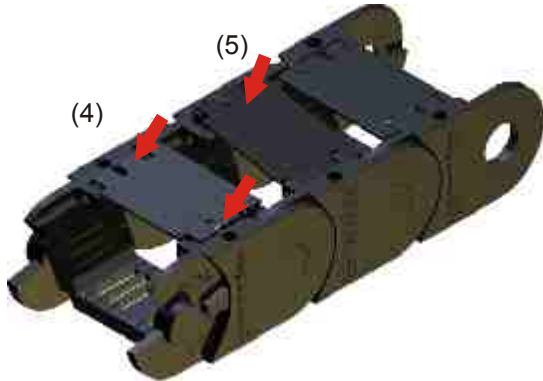

Lengthening and shortening

To lengthen or shorten the flap stays have to be opened. The walls with pivot pins are to press internally (1) and the walls with the holes are to press toward the outside (2). The chain links can be pushed together (3), or be pulled apart.

Installation of the flap stays

The assembly of the flap stays can take place before or after cable lining. Therefore energy chain does not need to be opened. The flap stays are inserted from the outside chain link floor until snap (1), (2). The dismantling of the stays is done by unlocking the tongue and pushing out (3).

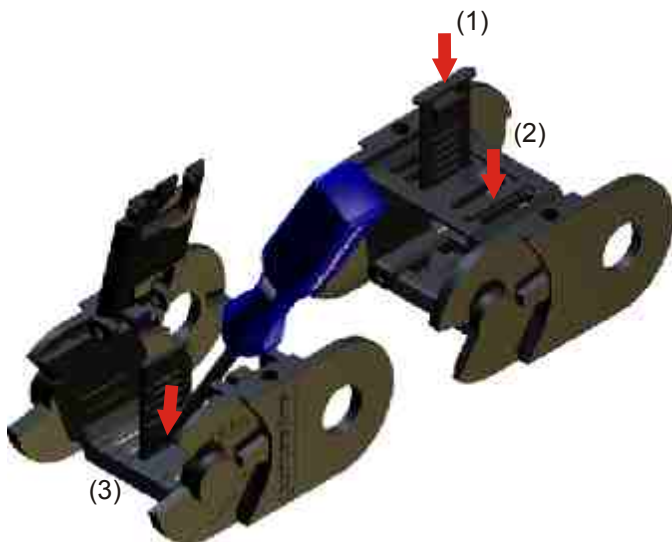
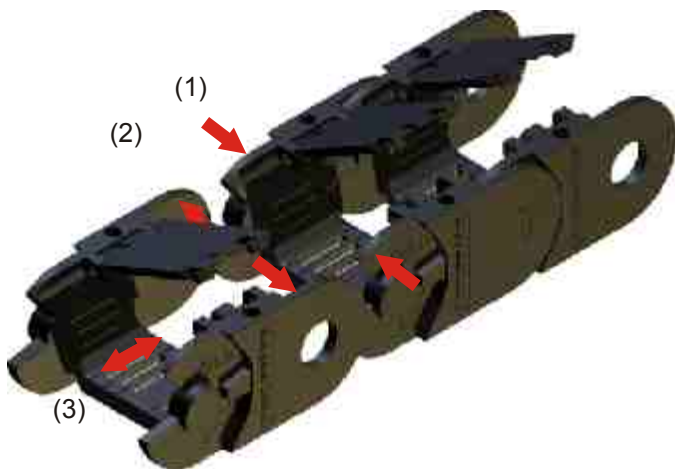

Assembly of horizontal dividers

The horizontal dividers (notched, telescopic and ladder-stay) are horizontally slid onto the vertical dividers (PZ) (1).

With a screwdriver the locking tongue can be mounted (2) and horizontal dividers disassembled (3).

Mounting the energy chain and strain relief

Before mounting the energy chain horn stays may be assembled which can be used to fix the lines via cable ties. For most applications variable strain relief is recommended, to mount the anchor profile with the energy chain using the integrated connector. (1), (2).

It is also possible to attach the anchor profile as a separate strain relief. The anchor profile is suitable for various strain relief components (see design guidelines).

When using the rigid type (00.000.2) as the final link the respective strain relief components are clipped onto the stay (1). Then the energy chain can be attached through the integrated connectors (2). The cables can then be fixed using cable ties with the horn stays (HS 65 and HS 85).

Alternatively, it is possible to mount the cable chains with flush mountig flange type brackets (1).

Maintenance of the energy chain

Kolibri energy chains are maintenance free. Like every mechanical system there will - depending on the ambient conditions - wear which must be observed. In case of this the energy chainspace has to be exchanged.

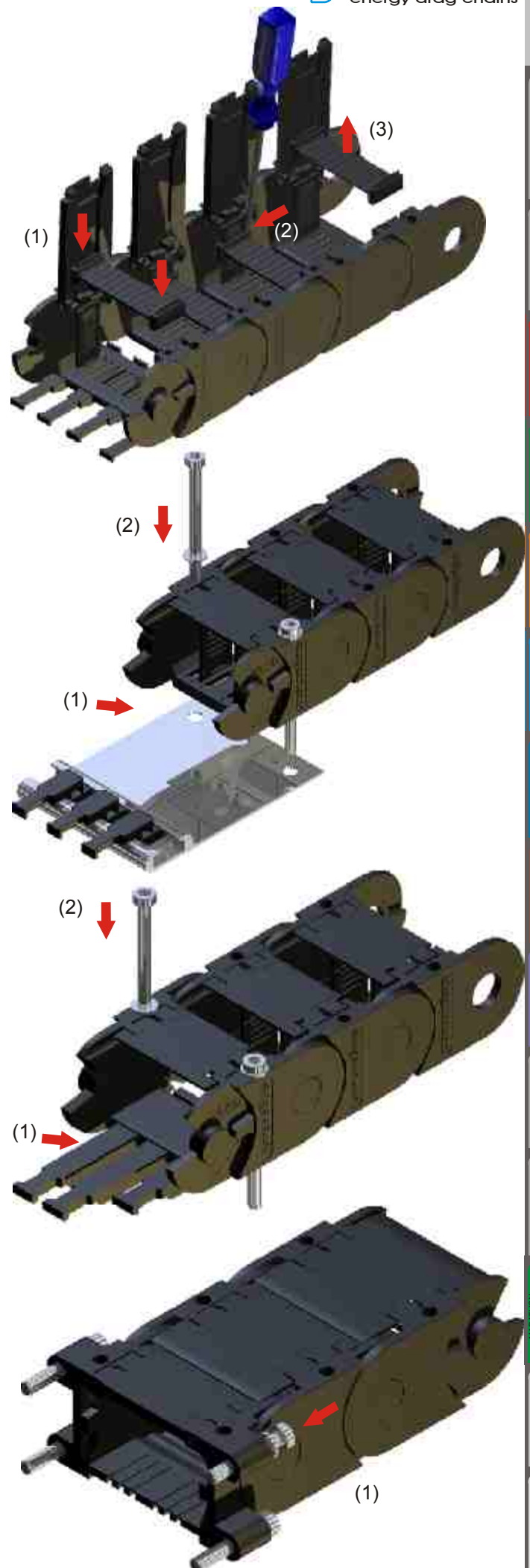

Kolibri 15.036.5
(Kolibri 02.5)

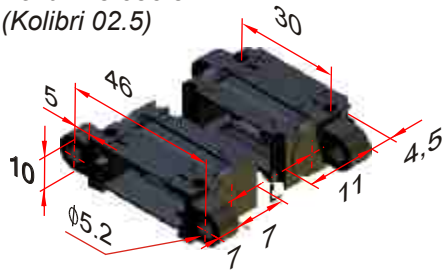

Kolibri 22.038.0
(Kolibri 05.0)

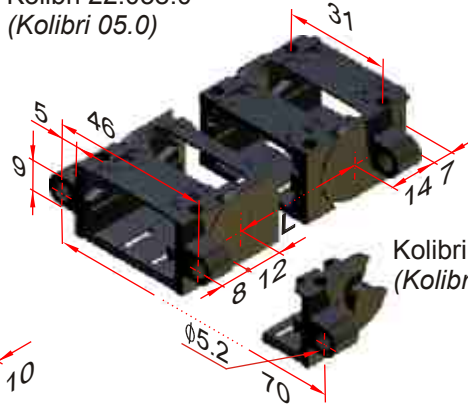

Kolibri 30.050.0
(Kolibri 10.0)

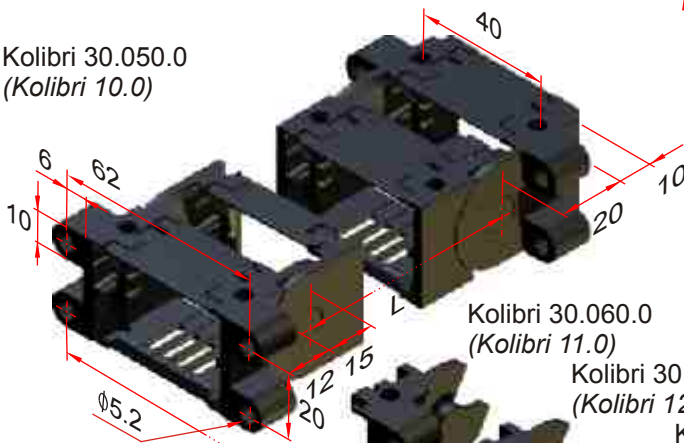

Kolibri 22.060.5
(Kolibri 07.5)

Kolibri 30.060.0
(Kolibri 11.0)

Kolibri 30.080.0
(Kolibri 12.0)

Kolibri 30.095.0
(Kolibri 13.0)

Kolibri 30.125.0
(Kolibri 14.0)

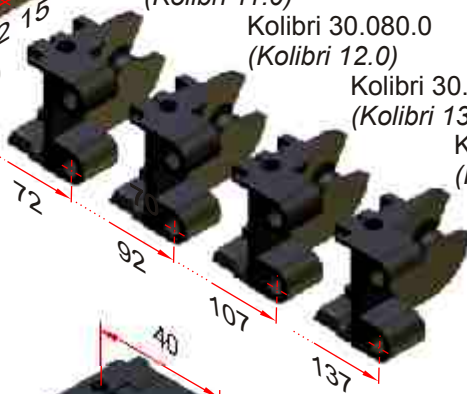

Kolibri 30.050.5
(Kolibri 10.5)

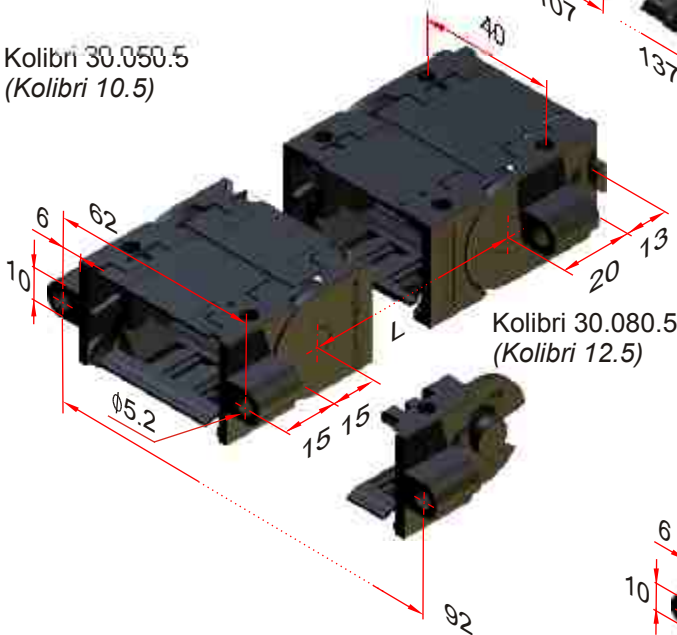

Kolibri 30.080.5
(Kolibri 12.5)

Kolibri 40.062.5
(Kolibri 15.5)

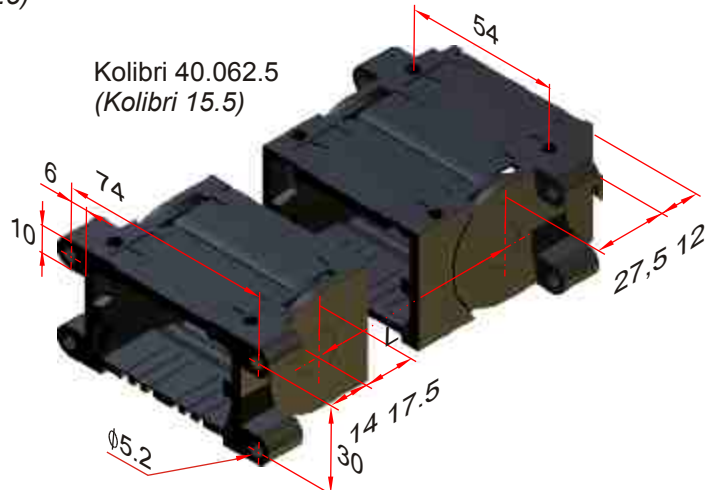

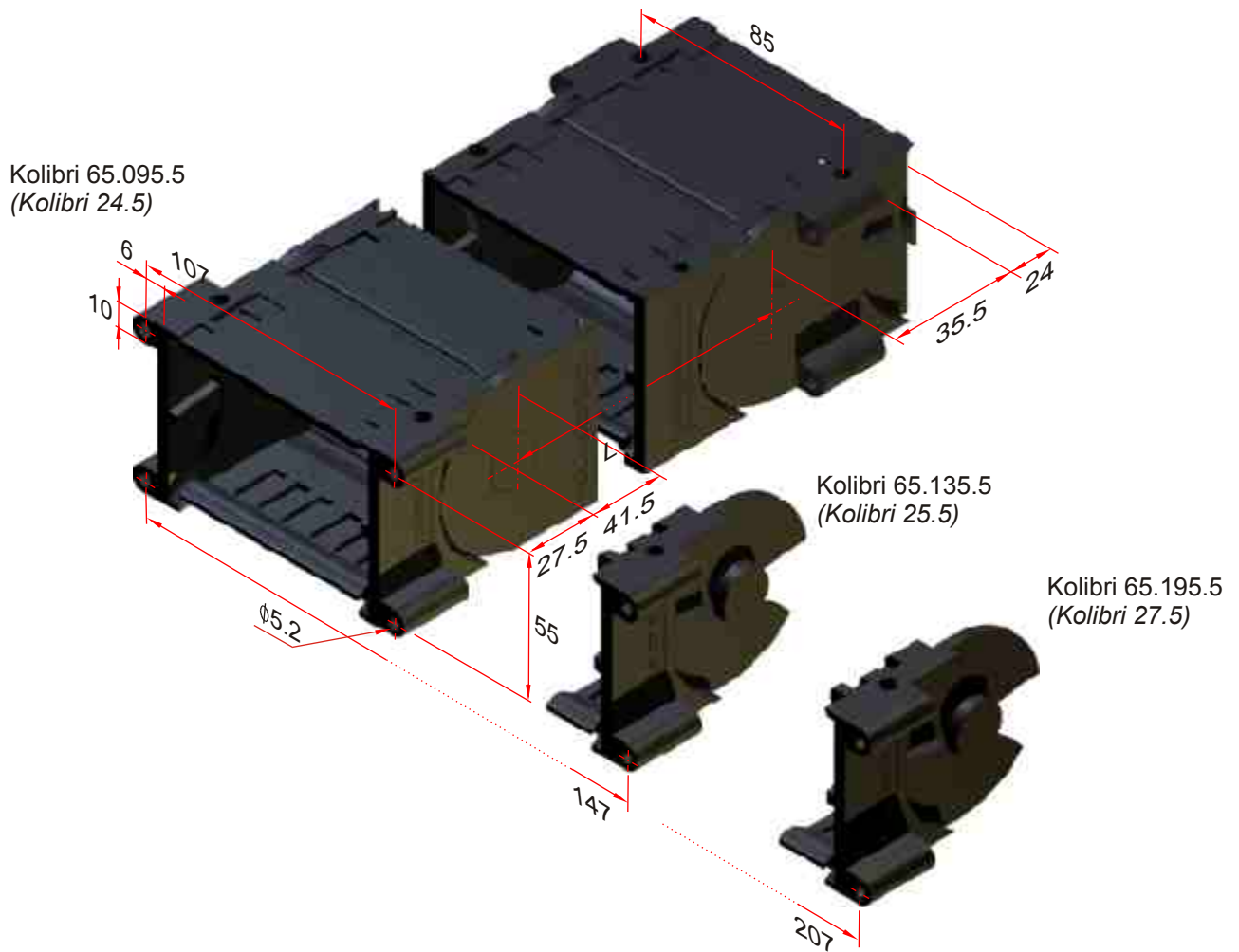
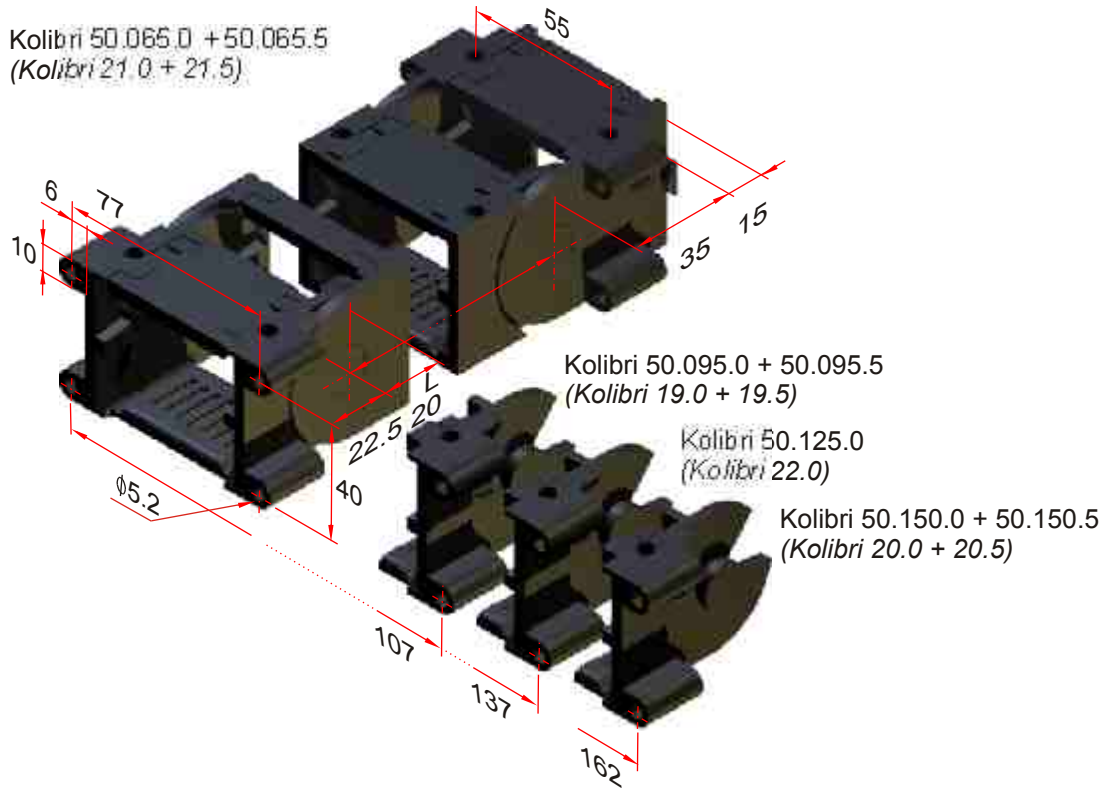

Kolibri parts 39



Kolibri	00.000.0 piece goods					00.000.1 (10m-coil)													
	Radius	15	17.5	20	30	35	40	50	60	70	75	100	125	150	175	200	250	300	400
10.012.4 (00.3)	1089	-	-	1090	-	-	1091	-	-	-	-	-	-	-	-	-	-	-	-
15.015.3 (0)	1056	0435	0029	-	-	-	-	-	-	-	-	-	-	-	-	-	-	-	-
15.015.4 (0.3)	-	-	1116	1060	-	-	-	-	-	-	-	-	-	-	-	-	-	-	-
15.036.5 (02.5)	-	-	-	1156	-	-	1157	-	-	-	-	-	-	-	-	-	-	-	-
15.037.3 (02)	-	-	1862	1861	-	-	-	-	-	-	-	-	-	-	-	-	-	-	-
15.051.0 (03)	-	-	0844	0845	-	-	-	-	-	-	-	-	-	-	-	-	-	-	-
22.025.4 (04.3)	-	-	-	0981	-	-	-	0982	-	0983	-	-	-	-	-	-	-	-	-
22.038.0 (05.0)	-	-	-	1686	-	1685	-	1684	-	1683	-	-	-	-	-	-	-	-	-
22.048.0 (06)	-	-	-	0840	-	-	-	0841	-	-	-	-	-	-	-	-	-	-	-
22.060.5 (07.5)	-	-	-	-	-	1259	-	1260	-	1261	-	-	-	-	-	-	-	-	-
30.030.3 (1)	-	-	-	-	0457	-	-	-	-	0004	-	-	-	0005	-	-	-	-	-
30.050.0 (10.0)	-	-	-	-	1224	-	1430	-	1225	1222	-	1226	-	1223	-	-	-	-	-
30.050.1 (10.1)	-	-	-	-	-	-	-	-	-	-	-	-	-	-	-	-	-	-	-
30.050.5 (10.5)	-	-	-	-	-	-	1002	-	1010	1008	-	1011	-	1004	-	-	-	-	-
30.060.0 (11.0)	-	-	-	-	1229	1377	-	-	1230	1227	-	1231	-	1228	-	-	-	-	-
30.060.1 (11.1)	-	-	-	-	-	-	-	-	-	-	-	-	-	-	-	-	-	-	-
30.080.0 (12.0)	-	-	-	-	1235	-	-	-	1236	1232	-	1233	-	1234	-	-	-	-	-
30.080.1 (12.1)	-	-	-	-	-	-	-	-	-	-	-	-	-	-	-	-	-	-	-
30.080.2 (12.2)	-	-	-	-	-	-	-	-	1394	1621	-	-	-	-	-	-	-	-	-
30.080.4	-	-	-	-	-	-	-	-	-	-	-	-	-	-	-	-	-	-	-
30.080.5 (12.5)	-	-	-	-	-	-	1798	-	-	1795	-	1796	-	1797	-	-	-	-	-
30.095.0 (13.0)	-	-	-	-	1239	-	-	-	1240	1352	1324	1241	-	1238	-	-	-	-	-
30.095.1 (13.1)	-	-	-	-	-	-	-	-	-	-	-	-	-	-	-	-	-	-	-
30.125.0 (14.0)	-	-	-	-	-	-	-	-	-	-	-	-	-	-	-	-	-	-	-
30.125.1 (14.1)	-	-	-	-	-	-	-	-	-	-	-	-	-	-	-	-	-	-	-
40.062.2 (15.0)	-	-	-	-	-	-	1489	-	1490	1491	-	1492	-	1493	-	-	-	-	-
40.062.5 (15.5)	-	-	-	-	-	-	-	-	1152	1163	-	1154	-	1155	-	-	-	-	-
40.075.2 (16.0)	-	-	-	-	-	-	1484	-	1485	1486	-	1487	-	1488	-	-	-	-	-
50.065.0 (21.0)	-	-	-	-	-	-	-	-	0971	0972	1256	0973	-	0974	0975	-	-	-	-
50.065.5 (21.5)	-	-	-	-	-	-	-	-	-	1005	-	1006	-	1007	1008	-	-	-	-
50.095.0 (19.0)	-	-	-	-	-	-	-	-	1138	1148	1431	1139	1325	1140	1141	-	-	-	-
50.095.2 (19.2)	-	-	-	-	-	-	-	-	1619	1644	1483	1370	-	-	-	-	-	-	-
50.095.5 (19.5)	-	-	-	-	-	-	-	-	-	1012	-	1013	-	1014	1016	-	-	-	-
50.125.0 (22.0)	-	-	-	-	-	-	-	-	1292	1288	-	1289	-	1290	1291	-	-	-	-
50.150.0 (20.0)	-	-	-	-	-	-	-	-	1287	1283	-	1284	-	1285	1286	-	-	-	-
50.150.5 (20.5)	-	-	-	-	-	-	-	-	-	1061	-	1062	-	1063	1064	-	-	-	-
65.095.1 (24.1)	-	-	-	-	-	-	-	-	-	-	-	-	-	-	-	-	-	-	-
65.095.5 (24.5)	-	-	-	-	-	-	-	-	-	-	1084	1085	-	1086	-	1087	-	-	-
65.135.1 (25.1)	-	-	-	-	-	-	-	-	-	-	-	-	-	-	-	-	-	-	-
65.135.5 (25.5)	-	-	-	-	-	-	-	-	-	-	1076	1077	-	1078	-	1079	1752	-	-
65.195.1 (27.1)	-	-	-	-	-	-	-	-	-	-	-	-	-	-	-	-	-	-	-
65.195.5 (27.5)	-	-	-	-	-	-	-	-	-	-	1080	1081	-	1082	-	1083	-	-	-
65.225.0 (29.0)	-	-	-	-	-	-	-	-	-	-	1356	1359	1357	-	1358	-	1360	-	-

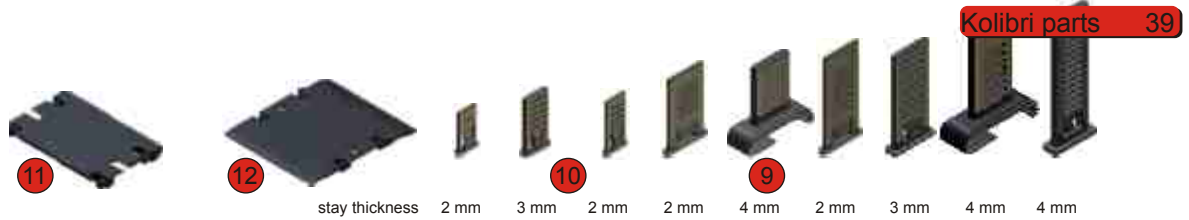

Kolibri

10.012.4	-	-	-	-	-	-	-	-	-	-	-	-
15.015.3	-	-	-	-	-	-	-	-	-	-	-	-
15.015.4	-	-	-	-	-	-	-	-	-	-	-	-
15.036.5	-	1708	-	-	-	-	-	-	-	-	-	-
15.037.3	-	-	-	-	-	-	-	-	-	-	-	-
15.051.0	1707	-	-	-	-	-	-	-	-	-	-	-
22.025.4	-	-	-	-	-	-	-	-	-	-	-	-
22.038.0	1687	-	1688	-	-	-	-	-	-	-	-	-
22.048.0	1707	-	-	-	-	-	-	-	-	-	-	-
22.060.5	-	1709	1294	-	-	-	-	-	-	-	-	-
30.030.3	-	-	-	-	-	-	-	-	-	-	-	-
30.050.0	1698	-	-	1258	-	-	-	-	-	-	-	-
30.050.1	1698	-	-	1258	-	-	-	-	-	-	-	-
30.050.5	-	1710	-	-	1017	-	-	-	-	-	-	-
30.060.0	1697	-	-	1258	-	-	-	-	-	-	-	-
30.060.1	1697	-	-	1258	-	-	-	-	-	-	-	-
30.080.0	1695	-	-	1258	-	-	-	-	-	-	-	-
30.080.1	1695	-	-	1258	-	-	-	-	-	-	-	-
30.080.2	1695	-	-	-	-	-	-	-	-	-	-	-
30.080.4	-	-	-	-	-	-	-	-	-	-	-	-
30.080.5	-	-	-	-	1017	-	-	-	-	-	-	-
30.095.0	1696	-	-	1258	-	-	-	-	-	-	-	-
30.095.1	1696	-	-	1258	-	-	-	-	-	-	-	-
30.125.0	1706	-	-	1258	-	-	-	-	-	-	-	-
30.125.1	1706	-	-	1258	-	-	-	-	-	-	-	-
40.062.2	1694	-	-	-	-	-	1521	-	-	-	-	-
40.062.5	-	1577	-	-	-	1268	-	-	-	-	-	-
40.075.2	1693	-	-	-	-	-	1521	-	-	-	-	-
50.065.0	1692	-	-	-	-	-	-	1113	-	-	-	-
50.065.5	-	1711	-	-	-	-	-	1113	-	-	-	-
50.095.0	1691	-	-	-	-	-	-	1113	-	-	-	-
50.095.2	1691	-	-	-	-	-	-	-	-	1451	-	-
50.095.5	-	1655	-	-	-	-	-	1113	-	-	-	-
50.125.0	1320	-	-	-	-	-	-	-	1326	-	-	-
50.150.0	1318	-	-	-	-	-	-	-	1326	-	-	-
50.150.5	-	1624	-	-	-	-	-	1113	-	-	-	-
65.095.1	1470	-	-	-	-	-	-	-	-	-	-	1129
65.095.5	-	1625	-	-	-	-	-	-	-	-	-	1129
65.135.1	1354	-	-	-	-	-	-	-	-	-	-	1129
65.135.5	-	1626	-	-	-	-	-	-	-	-	-	1129
65.195.1	1355	-	-	-	-	-	-	-	-	-	-	1129
65.195.5	-	1627	-	-	-	-	-	-	-	-	-	1129
65.225.0	1623	-	-	-	-	-	-	-	-	-	-	1129

Kolibri parts 39



Kolibri	FK	notched hor. divider flying	ladderstay	PTF flying	PT 55 55-80	PT 75 75-100	whole horizontal divider 25	50	head side flange
----------------	----	--------------------------------	------------	---------------	----------------	-----------------	--------------------------------	----	------------------

10.012.4	-	-	-	-	-	-	-	-	-	-
15.015.3	-	-	-	-	-	-	-	-	-	-
15.015.4	-	-	-	-	-	-	-	-	-	-
15.036.5	-	-	-	-	-	-	-	-	-	1339
15.037.3	-	-	-	-	-	-	-	-	-	-
15.051.0	-	-	-	-	-	-	-	-	-	-
22.025.4	-	-	-	-	-	-	-	-	-	-
22.038.0	-	-	-	-	-	-	-	-	-	1745
22.048.0	-	-	-	-	-	-	-	-	-	-
22.060.5	-	1127	-	-	-	-	-	-	-	1340
30.030.3	-	-	-	-	-	-	-	-	-	-
30.050.0	1363	-	-	-	-	-	-	-	-	1329
30.050.1	1363	-	-	-	-	-	-	-	-	1329
30.050.5	1363	1127	-	-	-	-	-	-	-	1341
30.060.0	1363	-	-	-	-	-	-	-	-	1330
30.060.1	1363	-	-	-	-	-	-	-	-	1330
30.080.0	1363	-	-	-	-	-	-	-	-	1331
30.080.1	1363	-	-	-	-	-	-	-	-	1331
30.080.2	1363	-	-	1665	1234	-	-	1663	1664	-
30.080.4	1363	-	-	-	-	-	-	-	-	1331
30.080.5	1363	1127	-	-	-	-	-	-	-	-
30.095.0	1363	-	-	-	-	-	-	-	-	1332
30.095.1	1363	-	-	-	-	-	-	-	-	1332
30.125.0	1363	-	-	-	-	-	-	-	-	1333
30.125.1	1363	-	-	-	-	-	-	-	-	1333
40.062.2	1363	-	-	1665	1234	-	-	1663	-	-
40.062.5	1363	-	-	-	-	-	-	-	-	1343
40.075.2	1363	-	-	1665	1234	-	-	1663	-	-
50.065.0	1269	1127	-	-	-	-	-	-	-	1336
50.065.5	1269	1127	-	-	-	-	-	-	-	1346
50.095.0	1269	1127	1127	-	-	-	-	-	-	1334
50.095.2	1269	-	-	1665	1234	-	-	1663	1664	-
50.095.5	1269	1127	1127	-	-	-	-	-	-	1344
50.125.0	1269	-	-	-	-	-	-	-	-	1337
50.150.0	1269	-	-	-	-	-	-	-	-	1335
50.150.5	1269	1127	1127	-	-	-	-	-	-	1345
65.095.1	1269	-	-	1665	1234	-	-	1663	1664	1347
65.095.5	1269	-	-	1665	1234	-	-	1663	1664	1347
65.135.1	1269	-	-	1665	1234	0879	0880	1663	1664	1348
65.135.5	1269	-	-	1665	1234	0879	0880	1663	1664	1348
65.195.1	1269	-	-	1665	1234	0879	0880	1663	1664	1349
65.195.5	1269	-	-	1665	1234	0879	0880	1663	1664	1349
65.225.0	1269	-	-	1665	1234	0879	0880	1663	1664	-

Kolibri PART NUMBERS



Kolibri anchor profile ZL50 blue ribbon ZLA 8 (PZ SLP220) ZHS10 ZLS10 HS55 HS65 HS75 HS85

10.012.4	-	-	-	-	-	-	-	-	-	-	-
15.015.3	-	-	-	-	-	-	-	-	-	-	-
45.015.4	-	-	-	-	-	-	-	-	-	-	-
15.036.5	-	-	-	-	-	-	-	-	-	-	-
15.037.3	-	-	-	-	-	-	-	-	-	-	-
15.051.0	-	-	-	-	-	-	-	-	-	-	-
22.025.4	1163	-	1142	1159	0778	1407	1160	-	-	-	-
22.038.0	1163	-	1142	1159	0778	1407	1160	-	-	-	-
22.048.0	1163	-	1142	1159	0778	1407	1160	-	-	-	-
22.060.5	1163	-	1142	1159	0778	1407	1160	-	-	-	-
30.030.3	1163	-	1142	1159	0778	1407	1160	-	-	-	-
30.050.0	1163	-	1142	1159	0778	1407	1160	1802	-	-	-
30.050.1	1163	-	1142	1159	0778	1407	1160	1802	-	-	-
30.050.5	1163	-	1142	1159	0778	1407	1160	-	-	-	-
30.060.0	1163	-	1142	1159	0778	1407	1160	1802	-	-	-
30.060.1	1163	-	1142	1159	0778	1407	1160	1802	-	-	-
30.080.0	1163	-	1142	1159	0778	1407	1160	1802	1503 ¹⁾	-	1812 ¹⁾
30.080.1	1163	-	1142	1159	0778	1407	1160	1802	1503 ¹⁾	-	1812 ¹⁾
30.080.2	1163	-	1142	1159	0778	1407	1160	-	1503	-	1812
30.080.4	1163	-	1142	1159	0778	1407	1160	-	1503	-	1812
30.080.5	1163	-	1142	1159	0778	1407	1160	-	-	-	-
30.095.0	1163	-	1142	1159	0778	1407	1160	1802	-	-	-
30.095.1	1163	-	1142	1159	0778	1407	1160	1802	-	-	-
30.125.0	1163	-	1142	1159	0778	1407	1160	1802	-	-	-
30.125.1	1163	-	1142	1159	0778	1407	1160	1802	-	-	-
40.062.2	1163	-	1142	1159	0778	1407	1160	-	1503	-	1812
40.062.5	1163	-	1142	1159	0778	1407	1160	-	-	-	-
40.075.2	1163	-	1142	1159	0778	1407	1160	-	1503	-	1812
50.065.0	1163	1273	1142	1159	-	1407	1160	-	-	-	-
50.065.5	1163	1273	1142	1159	-	1407	1160	-	-	-	-
50.095.0	1163	1273	1142	1159	-	1407	1160	-	1503 ¹⁾	1504	1812 ¹⁾
50.095.2	1163	1273	1142	1159	-	1407	1160	-	1503	-	1812
50.095.5	1163	1273	1142	1159	-	1407	1160	-	-	-	-
50.125.0	1163	1273	1142	1159	-	1407	1160	-	-	1504	-
50.150.0	1163	1273	1142	1159	-	1407	1160	-	-	1504	-
50.150.5	1163	1273	1142	1159	-	1407	1160	-	-	-	-
65.095.1	1163	1273	1142	1159	-	1407	1160	-	-	-	-
65.095.5	1163	1273	1142	1159	-	1407	1160	-	-	-	-
65.135.1	1163	1273	1142	1159	-	1407	1160	-	-	-	-
65.135.5	1163	1273	1142	1159	-	1407	1160	-	-	-	-
65.195.1	1163	1273	1142	1159	-	1407	1160	-	-	-	-
65.195.5	1163	1273	1142	1159	-	1407	1160	-	-	-	-
65.225.0	1163	1273	1142	1159	-	1407	1160	-	-	-	-

¹⁾ with horn stay connectors

PKK

- PKK applications 49
- PKK dimensions 50
- PKK types 52
- PKK sizes 54
- PKK parts 55
- PKK assembly 56
- PKK article numbers 62



closed + open

PKK CHARACTERISTICS

A development from many years of experience, which combines all the advantages of plastic energy chains to one system:

- positive locking stays
- fast stay assembly and disassembly
- easy to shorten and lengthen
- the three-dimensional chain

All ekd plastic energy chains are equipped with the integrated plastic connector. Additional components for attaching the energy chain are not required.

Dimensions

bending radii:	40	to	500 mm
inner height:	16	to	80 mm
inner width:	30	to	300 mm
energy chain weight:	0.6	to	3.4 kg / m
(see dimensions)			

Travel

The maximum range of travel is determined by the arrangement and the additional weight (line weight). At normal arrangement the maximum travel is double free carrying length. Support rollers or similar constructive steps can increase this value. Travel distances up to 100 meters are possible (see chapter on design guidelines).

Travel speed

There are no limits for the travel speed in general. But at gliding arrangements application specific influences have to be taken into account.

Acceleration

The acceleration is not subject to any restriction. Boundaries can only be achieved at high line tension forces encountered by the weights.

Temperature

Long term temperature limits are inbetween -20°C and 100°C.

Special versions

- | | |
|----------|------------------------|
| ELTOLA | ... silent running |
| ALLROUND | ... all movements |
| ATEX | ... EX-protection |
| ESD | ... antistatic |
| V-0 | ... self extinguishing |

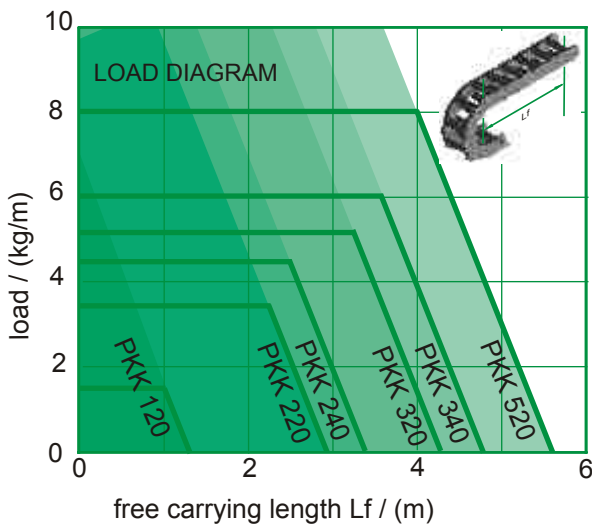

APPLICATION AREAS

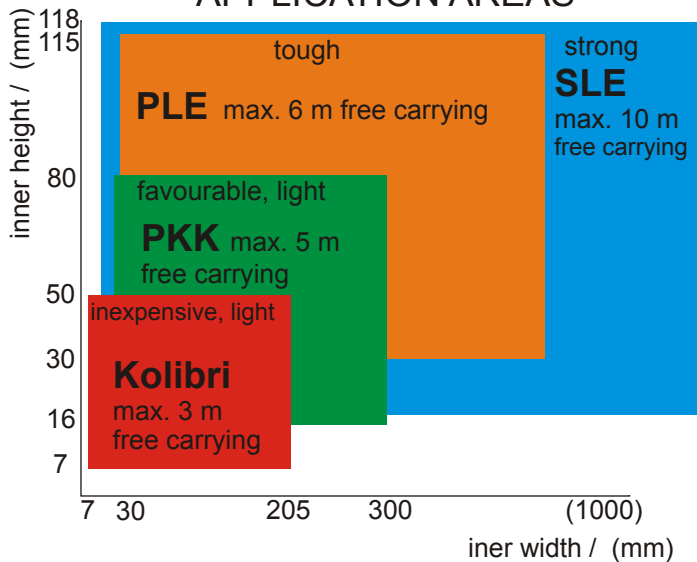



robotics, handling equipment,
machine tools,
textile machinery



PKK DIMENSIONS

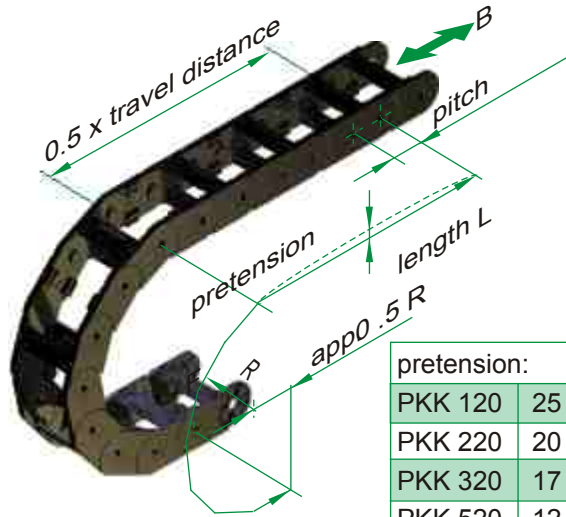
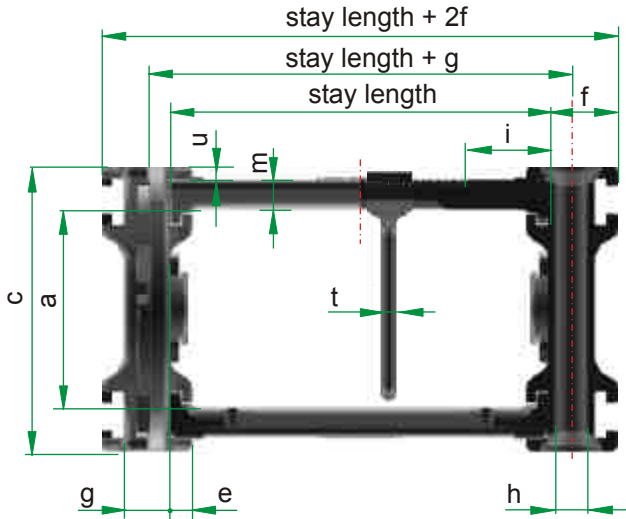

pretension:	
PKK 120	25 +/- 4 mm/m
PKK 220	20 +/- 4 mm/m
PKK 320	17 +/- 4 mm/m
PKK 520	12 +/- 4 mm/m



additional stay		v	r	s
PKK 213,223,243	short	19.5	14.5	-
		39	-	34
PKK 313,323	short	29.5	21.5	-
		59	-	51



slider	(see p.64) part no.	H	l	radius
PKK 128	0365	3	12	50 60 75
PKK 225	1740	5	18	100 150 200 300
PKK 228	0402	5	18	100 150
PKK 228	1742	8	18	200 250 300
PKK 325	1741	5	21	150 200 250 300 400
PKK 328	0432	5	21	150 200 250 300 400
PKK 328	0430	5	21	300 400
PKK 328	1632	8	21	300 400
PKK 528	1800	8	23	200 250 300 400 500
PKK 528	1801	8	23	300 400 500

friction coefficient: 0.2 to 0.25

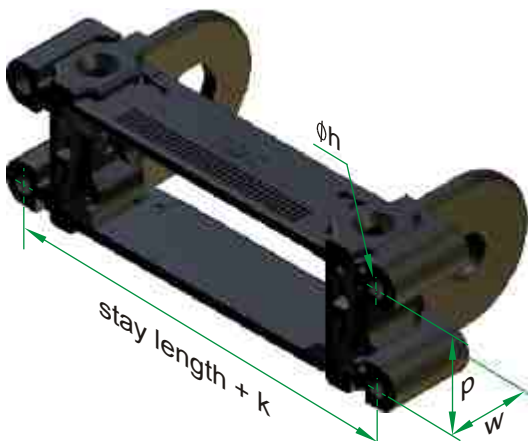

flange connector	k	p	w
PKK 120	28.5	15.5	16.5
PKK 220	40	34.5	30
PKK 320	46	55.5	40
PKK 520	50	85.5	40

PKK	Tlg.												Gewicht kg/m	
	a	c	e ¹⁾	f	g	h	i ²⁾	m ³⁾	t	u				
120 , 121, 125, 128	35	16	25	3	11	8	Ø4	15	3	2	1.5			0.60
110, 111, 115	35	16	25	3	8	8	Ø4	15	3	2	1.5			0.60
220 , 221, 223, 225, 228	65	34	50	5	15	10	Ø6	15	5	4	3			1.50
210, 211, 213, 215	65	34	50	5	10	10	Ø6	15	5	4	3			1.40
240, 241, 243, 245	65	44	60	5	10	10	Ø6	15	5	4	3			1.70
320 , 321, 323, 325, 328	90	51	75	6	18	12	Ø8	20	8	4	4			2.50
310, 311, 313, 315	90	51	75	6	12	12	Ø8	20	8	4	4			2.50
340, 341, 345	90	60	85	6	15	15	Ø8	20	8	4	4.5			2.70
520 , 521, 523, 525, 528	115	80	104	6	20	14	Ø8	20	8	4	3.5			3.40
510, 511, 513, 515	115	80	104	6	14	14	Ø8	20	8	4	3.5			3.20
bending radius R [mm]														
120 , 121, 125 ⁴⁾ , 128 ⁶⁾	40	50	60	75										
110, 111, 115 ⁴⁾	40	50	60	75										
220 , 221, 223, 225 ⁴⁾ , 228 ⁶⁾				75	100		150		200	250	300			
210, 211, 213, 215 ⁴⁾			65	75	100	125	150		200	250	300			
240, 241, 243, 245 ⁴⁾				75	100		150		200	250	300			
320 , 321, 323, 325 ⁴⁾ , 328 ⁶⁾					100		150		200	250	300	400		
310, 311, 313, 315 ⁴⁾					100	130	150		200		300	400		
340, 341, 345 ⁴⁾					100		150		200	250	300	400		
520 , 521, 523, 525 ⁴⁾ , 528 ⁶⁾							150		200	250	300	400	500	
510, 511, 513, 515 ⁴⁾							150		200	250	300	400	500	
stay length [mm] ¹⁾														
120 , 110, 111, 121, 128	30	50	60	70	80	90	100	110	120					
115, 125	50						100							
220 , 210, 211, 213, 221, 223, 228	50	60	70	80	90	100	110	120	130	150	170		200	220
215, 225 ⁵⁾	50					100				150			200	
240, 241, 243	50	60	70	80	90	100	110	120	130	150	170		200	220
245 ⁵⁾	50					100				150			200	
320 , 310, 311, 313, 321, 323, 328	50	60	70	80	90	100		120	130	150	170	180	200	230 250 300
315, 325 ⁵⁾						100				150			200	
340, 341	50	60	70	80	90	100		120	130	150	170	180	200	230 250 300
345 ⁵⁾						100				150			200	300
520 , 510, 511, 513, 521, 523, 528	50	60	70	80	90	100		120	130	150	170		200	250 300

1) The usable interior width is stay length - 2e minus the width of the used PZ
 2) First latching the PZ (latching all 2mm)
 3) Dimension does not apply to the closed type
 4) PKK 115 and 125 from R50, 215 and 225 from R100, 245, 315 and 325 from R150, 345, 525 and 515 from R200
 5) The inner radius covers (ASI) of length 200 mm of the PKK 215, 225, 245 and 300 mm of the PKK 315, 325, 345 are designed with a pivot on one side.
 6) PKK 128 from R 50, PKK 228 from R100, PKK 328 from R150, PKK 528 from R200

PKK TYPES

PKK 120, 220, 320, 520

The standard version has a stay in every second link. With additional link bands and stays the chains can be extended as multibandchains. The **integrated connector** makes each link in the chain to a mounting link.



order example

PKK 220	/ 100	x 3510	/ 100
type	radius	length	stay length

PKK 110, 210, 240, 310, 340, 510

The smooth designed PKK corresponds to the standard version, but has no exterior T-slot. These types provide a very good visual effect and a smaller width through the flat outside surfaces (also see PKK 215, PKK 245). The PKK 240 and 340 offer larger cross sections due to the increased link height.



order example

PKK 240	/ 100	x 3510	/ 100
type	radius	length	stay length

PKK 121, 221, 321, 521

The types PKK -21 are manufactured with a stay in each link. The additional stays increase the lateral stability and optimize guiding of particularly smaller cable diameter.



order example

PKK 221	/ 100	x 3510	/ 100
type	radius	length	stay length

PKK 111, 211, 241, 311, 341, 511

These are the smooth designs with a stay in each link to increase lateral stability and optimize guiding of particularly small cables. PKK 241 and PKK 341 have a higher capacity due to their increased link height.

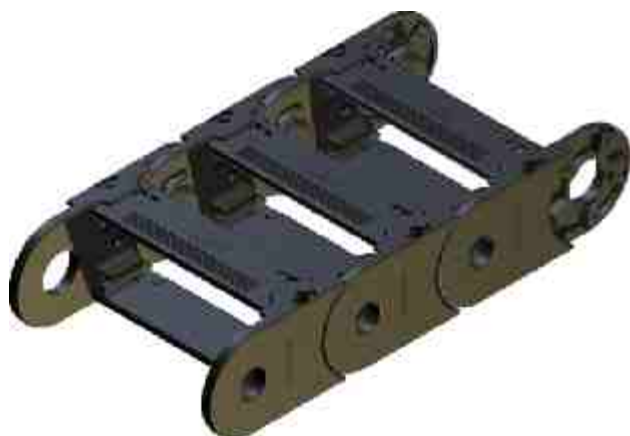

order example

PKK 241	/ 100	x 3510	/ 100
type	radius	length	stay length

PKK 213, 223, 243, 313, 323, 513, 523

The PKK with extension stays in the inner radius. Suitable for low speeds these stays create additional space. The extension stays can be arranged in the outer radius or in other combinations as per optional drawing. The extension stays are available in two lengths.

order example

PKK 223	/ 100	x 3510	/ 100
type	radius	length	stay length

PKK 125, 225, 325, 515, 525

The closed designs offer optimum protection of the lines against chips or against UV radiation. The covers can be opened in the inner or outer radius. The closed types may also be subsequently created from the standard version.

PKK 115, 215, 245, 315, 345

Without T-slot on the outside, the closed types achieve a good visual effect with their flat sides and a smaller width.

order example

PKK 215	/ 100	x 3510	/ 100
type	radius	length	stay length

PKK 128, 228, 328, 528

The PKK 128, 228 and 328 with sliders are designed for gliding arrangements (long travel distances) and are fitted with stays in each link. The sliders are mounted in the inner radius of the energy chain and have a very low coefficient of friction ($\mu = 0.2$ to 0.25).

The sliders can also be installed afterwards. At low stroke rates and low speeds ($<1\text{m/s}$) sliders are not necessary. The smallest radius of each dimension of the PKK is not suitable for sliders.

order example

PKK 228	/ 100	x 3510	/ 100
type	radius	length	stay length

Multiband energy chains

Multiband energy chains can be created by attaching additional link bands. These are assembled through stays at standard energy chains (see assembly, except PKK with smooth exteriors).

order example

PKK 220	/ 100	x 3510	/ 100 / 100
type	radius	length	stay length / stay length

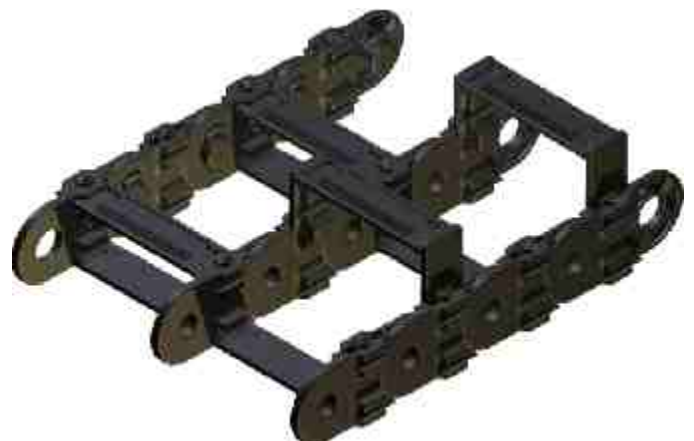
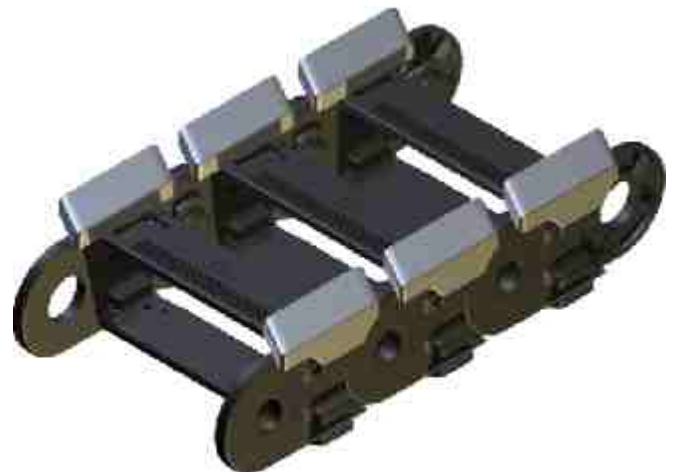
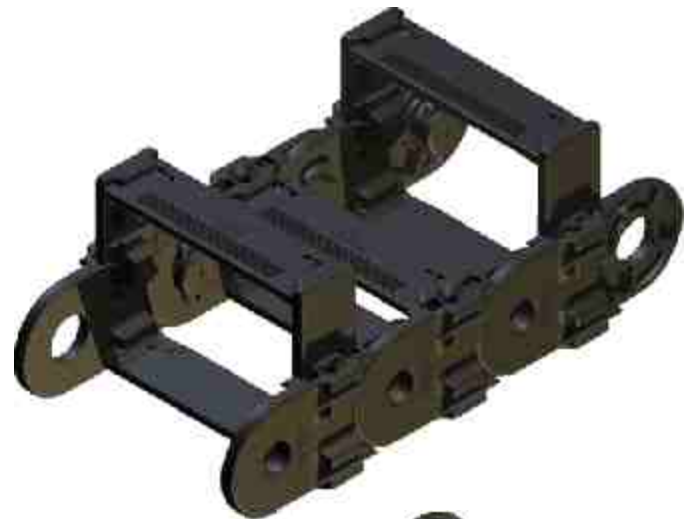

PKK SIZES

PKK120

height:	25	width:	64 ... 97
inner height:	16	inner width:	30 ... 110

PKK 220

height:	50	width:	80 ... 330
inner height:	34	inner width:	50 ... 200

PKK 240

height:	60	width:	70 ... 320
inner height:	44	inner width:	50 ... 200

PKK 320

height:	75	width:	86 ... 336
inner height:	51	inner width:	50 ... 300

PKK 340

height:	85	width:	80 ... 330
inner height:	60	inner width:	50 ... 300

PKK 520

height:	104	width:	90 ... 340
inner height:	80	inner width:	50 ... 300

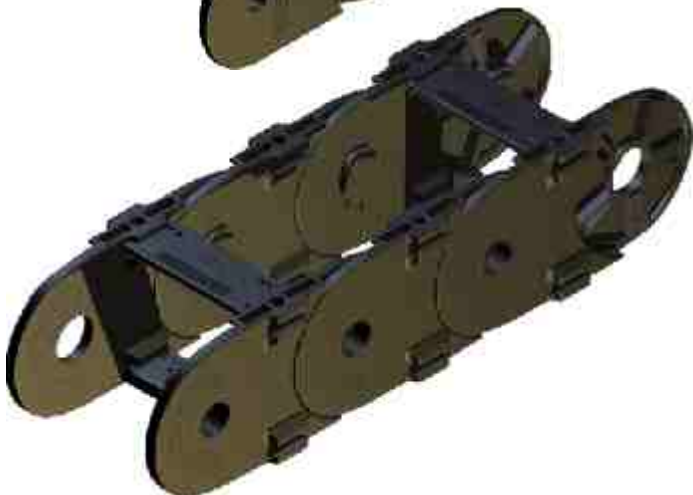
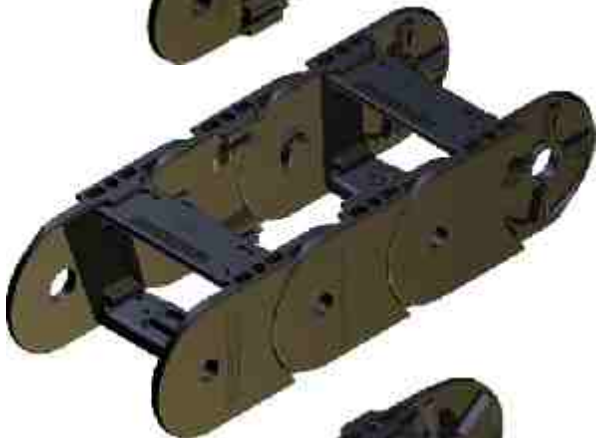
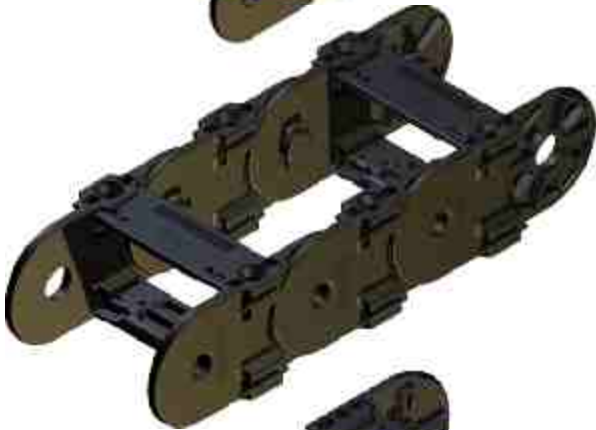

- | pos. | name |
|--------|---|
| 1 | PKK 220 link |
| 2 | PKK 210 link |
| 3 | UFA / Z (universal flange connector pivot) |
| 4 | UFA/B (universal flange connector drilling) |
| 5 | PKK 220 connector link short (drilling) |
| 6 | PKK 220 connector link short (pivot) |
| 7 | head side flange |
| 8 | spreader |
| 9 | 22 stay 100 |
| 10 | 22ASI 100 (inner cover) |
| 11 | 22ASA 100 (outer cover) |
| 12 | cover holder |
| 13,13a | PZ (plastic divider) |
| 14 | PT 55/PT 75 (telescopic horizontal divider) |
| 15 | extension stay long |
| 16 | extension stay short |
| 17 | slider R100 |
| 18 | damping element |
| 19 | band holder |
| 20 | ladder stay |
| 21 | hole layer stay 25 |
| 22 | hole layer stay 50 |
| 23 | horn stay 220 |

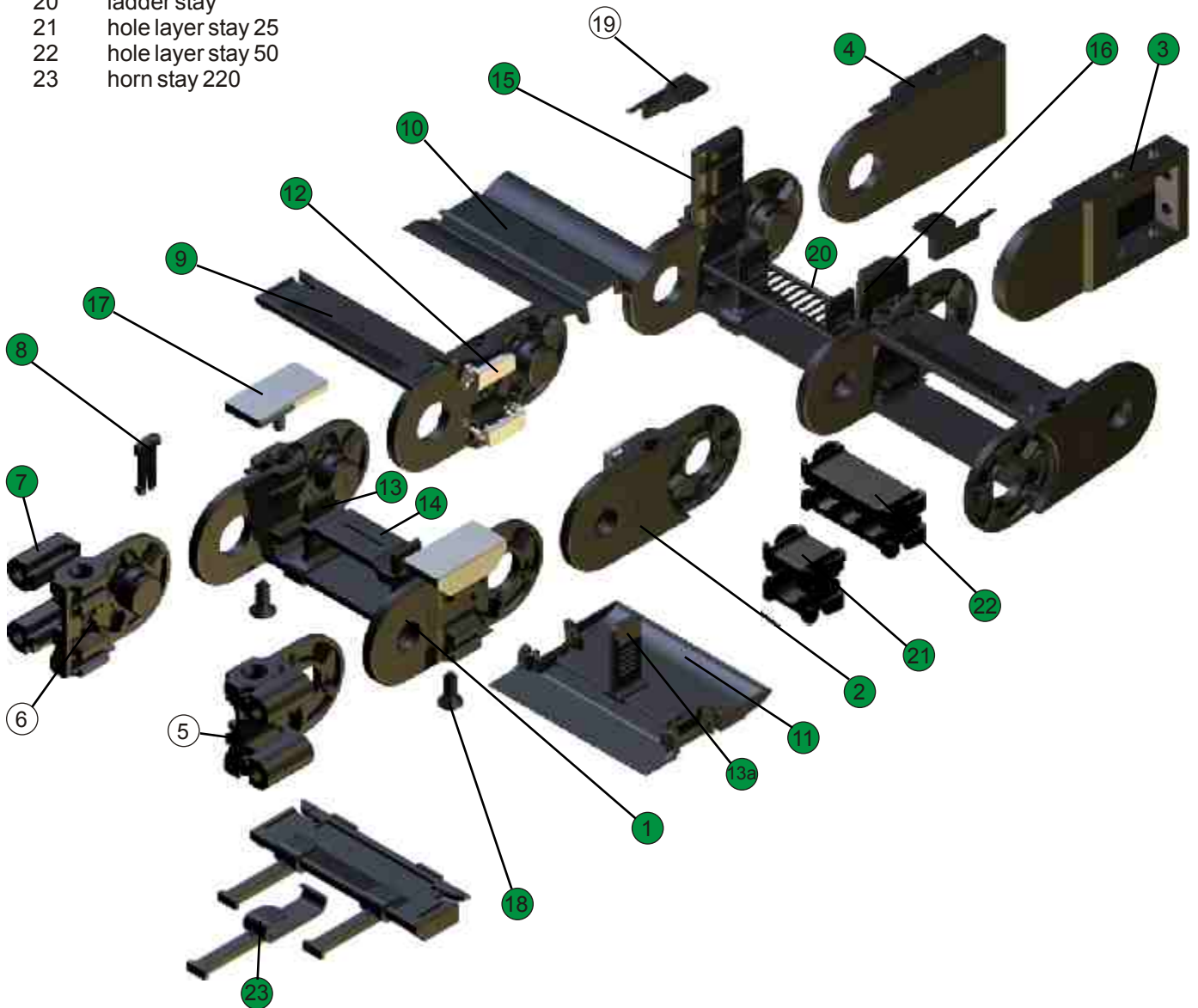

Packaging

ekd energy chains are supplied in transport friendly packaging. When removing the packaging and during removal of the energy chain or parts of it, ensure that the energy chains are free of torsion and tension, to avoid mechanical damage.

Lengthening or shortening, linkbands

Lengthening of the energy chain is done by fitting of energy chain pieces or links (1) and lock with spreader (2). To shorten the spreader is disengaged and removed, then the piece of chain removed.

Alternatively first link strands may be mounted and then stays assembled.

For the PKK the opposite link strands are rotated by 180 ° and arranged with the pivot on the inner chain.



Stay assembly

The stays with the locking tabs are put in the T-guide of the link (1) and push until it clicks into the guides (2).

The stays can be positioned initially in the T-guide and will be engaged in one swoop (plastic hammer or similar) in the final position.

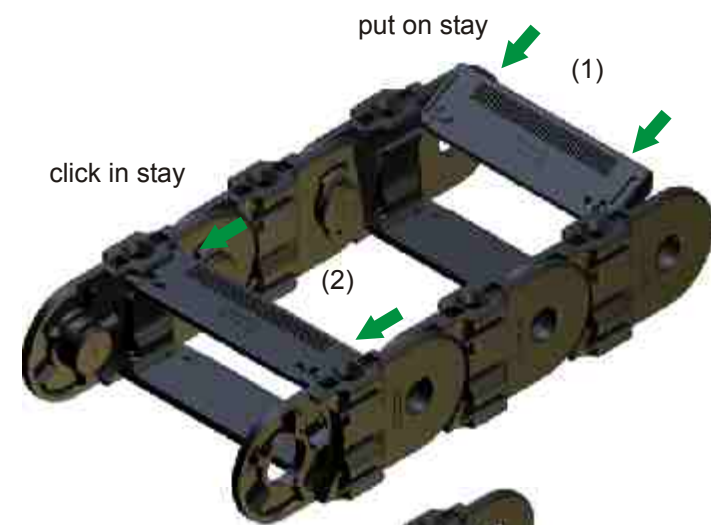

Stay disassembly

The lock tongue of the stays are unlock with a screwdriver (1) and the stays pushed out with light pressure to the front of the T-slot (2). For medium and larger series (from PKK220) the stays can be unlocked with a light hit on the lock tongue (plastic hammer or similar) and then ejected.

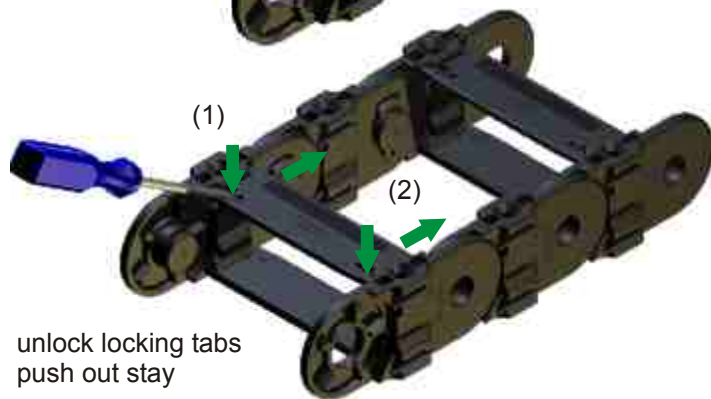

Plastic divider PZ (vertical)

The PZ will be placed in the designated position on the stay (1) and engaged (2). The PZ can be mounted fixed or movable.

The dismantling is done by unlocking (3) and removal of the PZ.

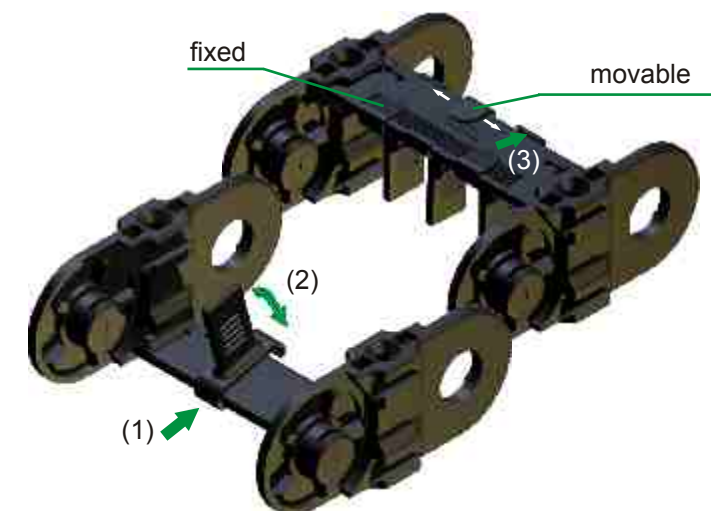

Telescopic divider and ladder divider

The telescopic horizontal divider and ladder stay horizontally pushed onto the plastic divider (PZ) and engaged in the designated height (1). The disassembly is done with a screwdriver through pull (2) and removal (3).

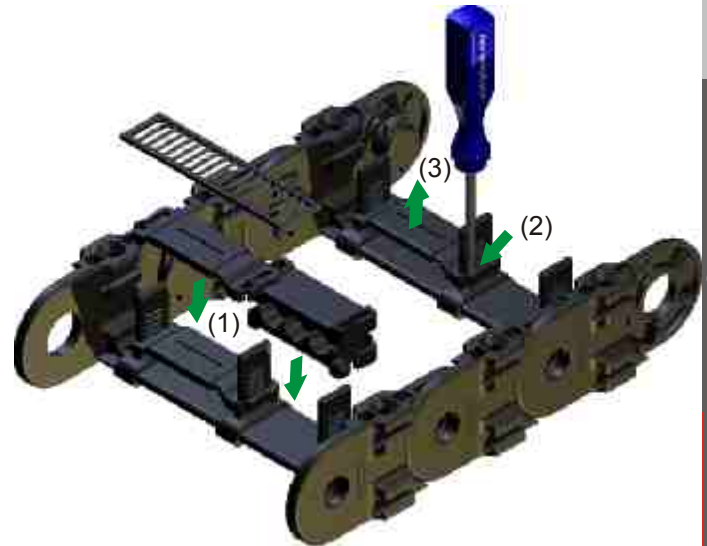

Hole layer stay

The mounting of hole layer stay is the same as the assembly of the telescopic horizontal divider and the ladder stay. Before assembling the second component the lines should be inserted. The disassembly is done with a screwdriver by unlocking and removal.

Extension stays

The extension stays are pushed onto the link guides (1) and pivoted until it clicks (1). Then the stays are pushed into the guides until it clicks (3).

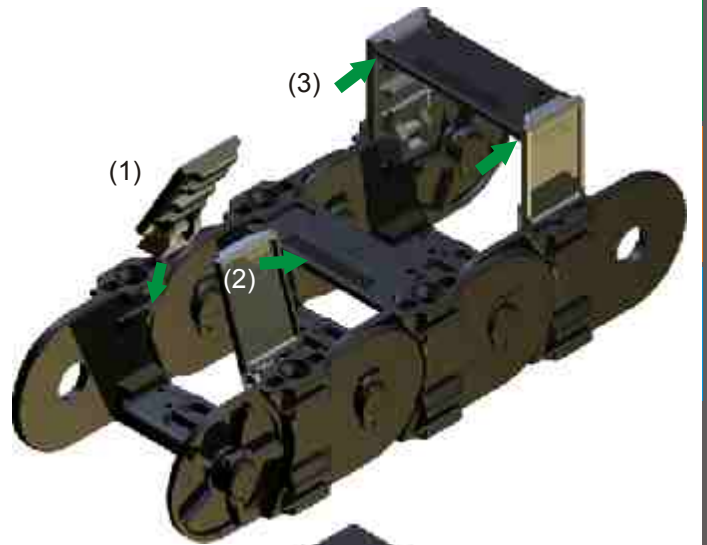

Covers

Before installing covers (ASA/ASI) first segment holder have to be pushed in the T-slot of the links (1). Then the covers can be plugged in (2). Covers and segment holder snap in the end position.

The covers are marked with arrows, to avoid wrong assembly direction. Covers for the outer radius are equipped with holders for divider (PZ). During assembly, ensure the correct overlap of the covers and that the covers are engaged on all four locking points.

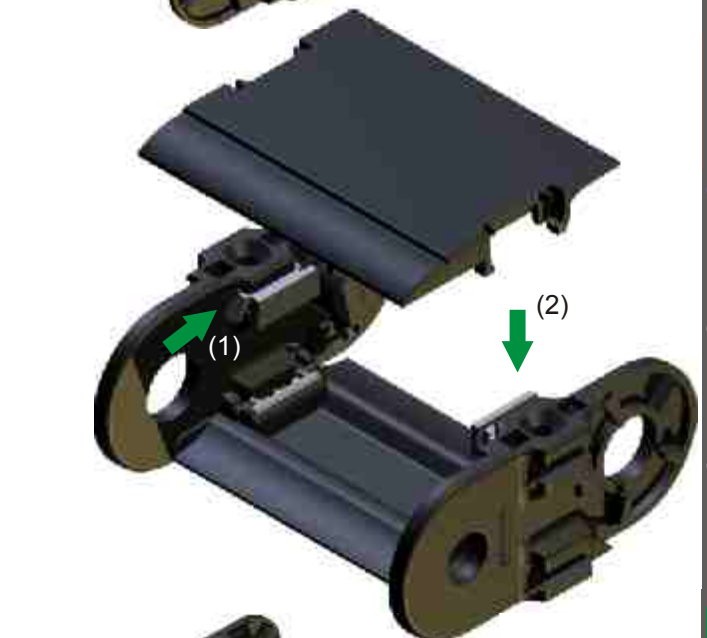

The inner radius covers (ASI) of length 200 mm of the PKK 215, 225, 245 and 300 mm of the PKK 315, 325, 345 are designed with a pivot on one side. The cover has to be pushed into the T-slot of the link on its pivot side (1) and can swing to close or open (2). For that the cover holder has to be unlocked (see disassembly).

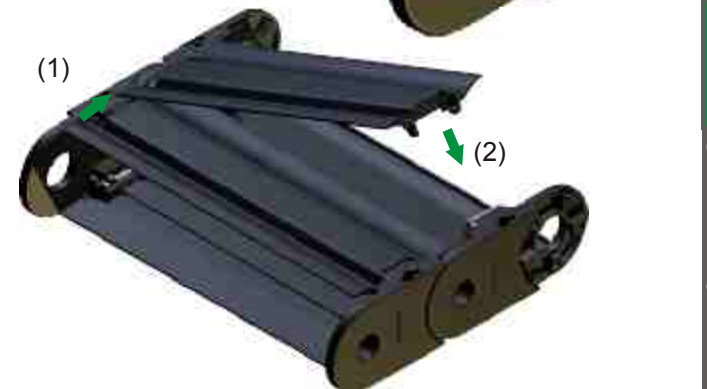

The dismantling of the covers is done by unlocking and lifting out. These are done one by one at a time with the 4 locking tongues on the segment holders using a screwdriver (1), then the cover is easy to raise.

With two release tools all four locking tongues can be done at once and the cover removed.

Attention:
The release tools can only be resolved if covers are dismantled (by lateral withdrawal)

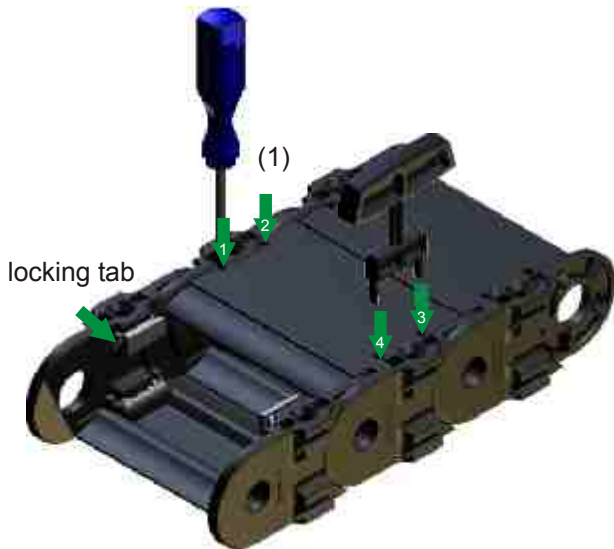

Covers with lengths 200 mm and 300 mm of the PKK 225 and 325 are equipped with a pivot on one side. These covers opening mechanism is deactivated on one side. The covers can be swiveled.

Sliders

The sliders are mounted in the inner radius of the energy chain. The minimum bend radius in each PKK size can not be fitted with sliders.

During assembly of the sliders be aware of the following:

The sliders must be conditioned (water content min. 1%, overnight storage in water at room temperature or 2 h at 80 ° C).

Heat the slider just before mounting in a water bath.

Avoid impact load.

The dismantling is carried out channel lock pliers as shown and unlock slider by turning it to the outer side.

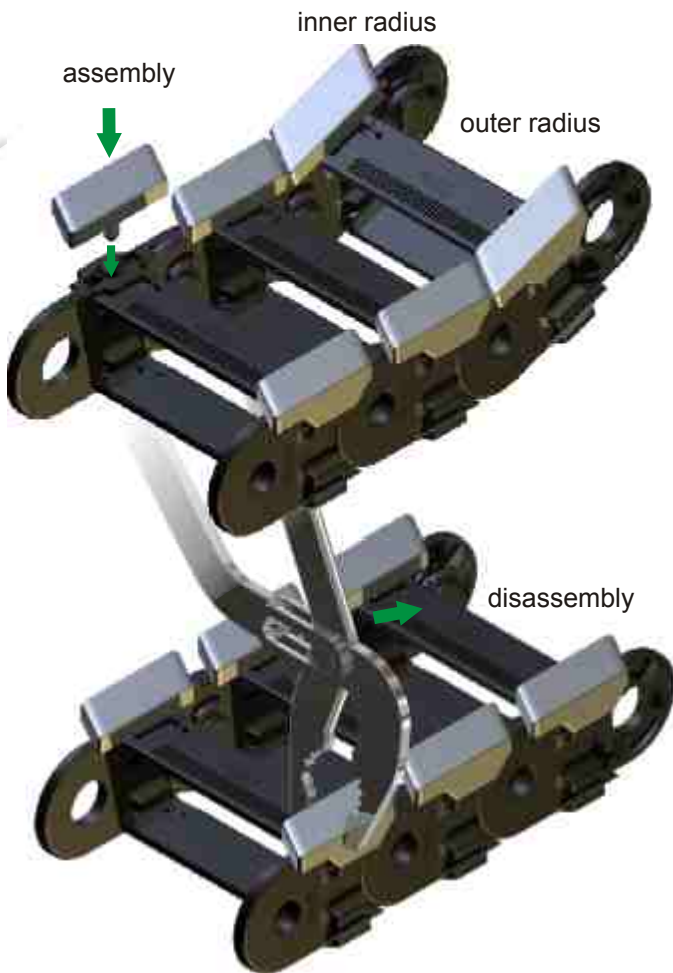

Multiband energy chains

Multiband energy chains can be created by attaching additional link strands. These are attached to existing energy chains by additional stays (see stay assembly).

By combining with extension stays large hoses or other additional components may be carried.

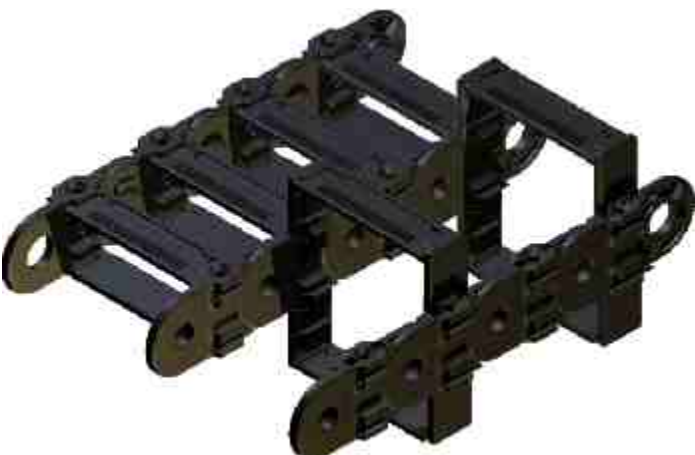

Mounting the energy chain

All ekd plastic energy chains are equipped with the **integrated connector** (1). When using integrated strain relief, no additional components are needed. Provision for the combined strain relief, the anchor profile has to be screwed with the first link in the chain. Separate strain relief can be subsequently mounted.

Headside mounting

Optionally, the attachment can be made with flange connectors or universal connectors. The flange connectors are mounted in the T-slots of short connectors links until locking (1). The energy chains can be attached through four flange connectors (2).

The universal flange connectors are mounted like the links with the spreader (3) and provide universal connection options.

Strain Reliefs

With long travel distances and high speeds the lines at one end of the cable carrier, preferably on the moved driver, are attached to strain reliefs. The distance of strain relief to the bending area depends on the particulars of the line manufacturer.

Integrated strain relief

In this space-saving type strain reliefs are directly mounted on the vertical divider (PZ) of the first link of the energy chain.

The mounting direction of the PZ must be chosen so that tension directed on the chain can not unlock the divider.

In order to avoid premature line wear caused by dynamic loads a small extra chain length is recommended.

Combined strain relief

The combined strain relief combines the advantage of sufficient distance from the strain relief to the bending line areas provided by a simple and space-saving installation of the integrated strain relief.

The anchor profile is fitted to the drilling dimensions of the energy chain (integrated connectors) and attached to this. The lateral insertion and extraction of strain relief elements is possible at any time.

Separate strain relief

The separate strain relief is recommended for high dynamic loads and large line diameters. A sufficient distance from the strain relief to the chain is easy to implement.

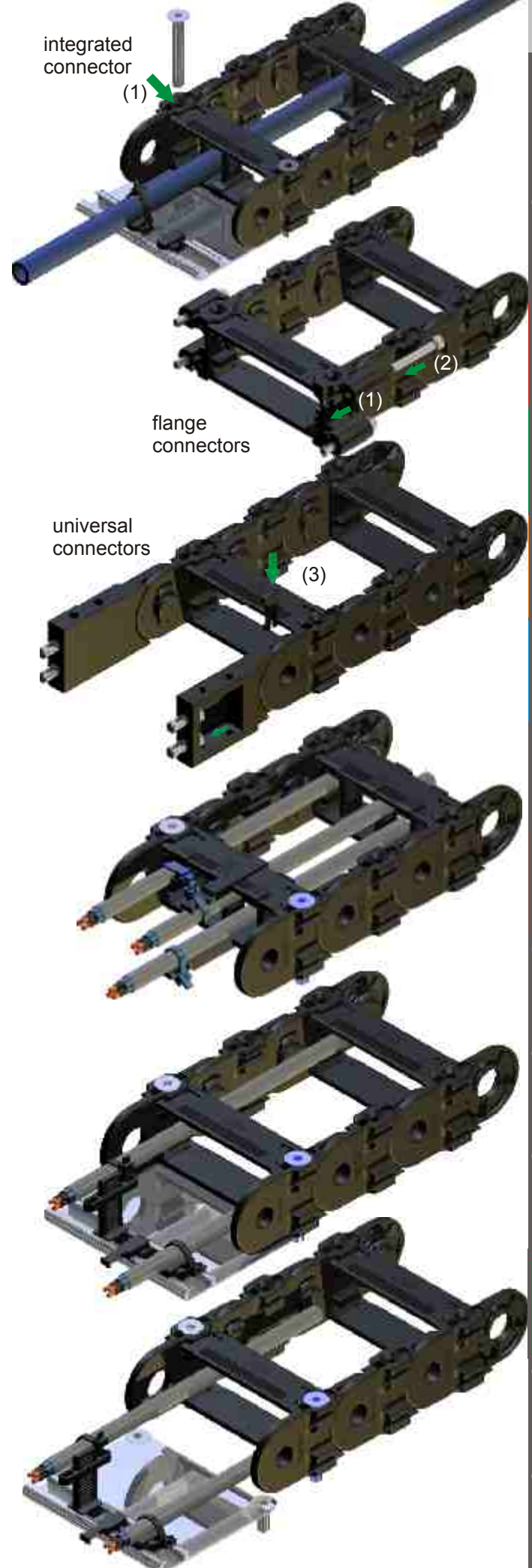

ZLP XX part no. 1163
(xx = chain width)

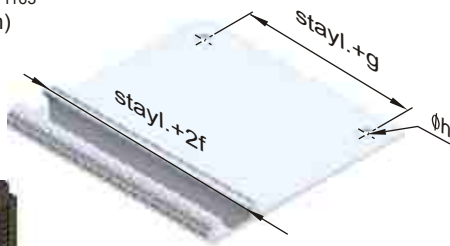

ZL 100
part no. 1612

ZL 80
part no. 1675

ZL 50
part no. 1273

$\text{Ø}7 < D < \text{Ø}35$

ZLB24
part no. 1142

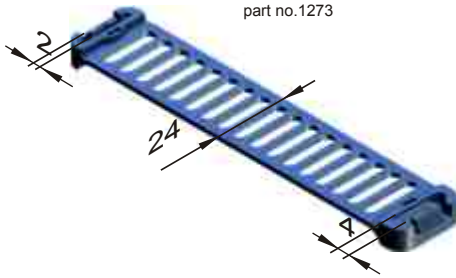

ZLS10
part no. 1160

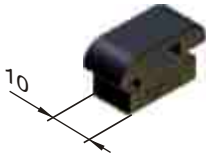

ZLA8
part no. 1159

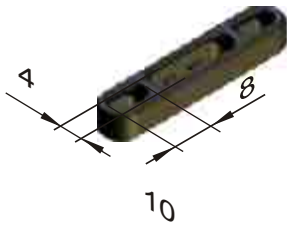

ZHS10
part no. 1407

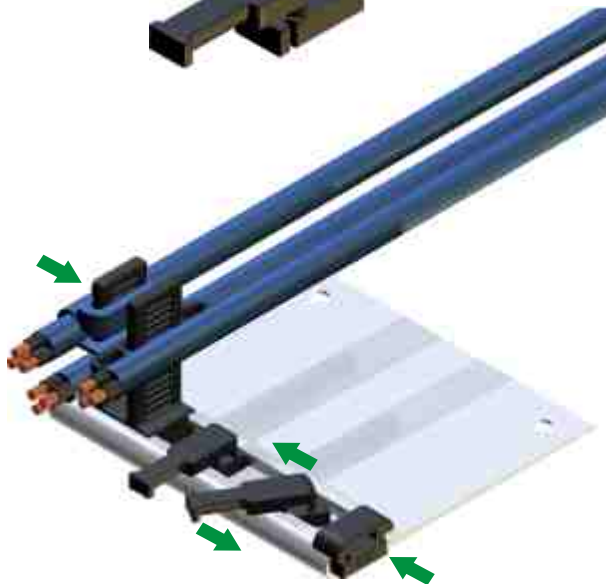
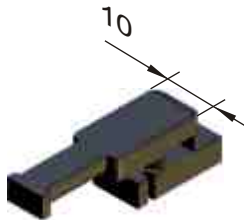

PKK ASSEMBLY

ANCHOR PROFILE ZLP

The aluminum anchor profile is used to mount various of strain relief elements. Both the distance to the energy chain as well as the positioning of the strain relief elements can be designed.

STRAIN RELIEF STAY PZL

The design of this strain relief stay is closely based on the plastic vertical divider (PZ). It is laterally inserted into the anchor profile or a c-profile and can accommodate multiple strain relief elements.

BLUE RIBBON ZLB 24

The Blue Ribbon is a special ekd developed cable tie with a 24 mm wide fixing area for cable diameters of 7 mm to 35 mm. The Blue Ribbon can be locked on the strain relief stay. The lines may be fixed single or multiple (s-shaped) with the Blue Ribbon.

PUSH ANCHOR ZLS 10

The push anchor is laterally inserted into the anchor profile or a c-profile. The lines are fixed with standard cable ties on the push anchor.

CABLE ANCHOR ZLA 8

The cable anchor is pushed onto the strain relief stay and can be fixed by the latching at different altitudes. The line is connected with commercially available cable ties on the cable anchor (single or double).

HORN STAY ZHS 10

The horn stay ZHS10 is transversely inserted into the anchor profile and locked by a 90° rotation. The line is fixed with cable ties at the horn.

YOKE CLAMPS

Commercially yoke clamps can be used as a separate strain relief (see below) and can be mounted with the aluminum c-profile of the SLE 520, SLE 320 in front of the energy chain connectors.

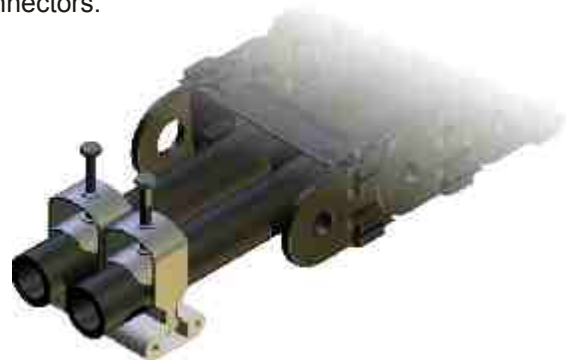

Maintenance of the energy chain

PKK energy chains are maintenance free. Like every mechanical system there will - depending on the ambient conditions - wear must be observed.

In case of this the energy chain has to be replaced.

For long travels or even in a circular motion, the energy chains are often equipped with sliding elements. These allow sliding of the upper part of the chain on a suitable surface (eg, slider-slider, slider-steel, glide bar).

The sliders show wear according to the application due to abrasion. The slider surfaces should be checked at regular intervals on their condition. With a thickness of 1-2 mm sliders have to be replaced.



link



PKK

PKK

	R	40	50	60	75
110,111	m.V.	1598	1599	1600	1601
	o.V.	1605	1604	1603	1602
113	m.V.	1598	1599	1600	1601
	o.V.	1605	1604	1603	1602
115	m.V.	1598	1599	1600	1601
	o.V.	1605	1604	1603	1602

	R	40	50	60	75
120, 121	m.V.	0380	0379	0378	0377
	o.V.	1717	1716	1715	1714
123	m.V.	0380	0379	0378	0377
	o.V.	1717	1716	1715	1714
125	m.V.	0380	0379	0378	0377
	o.V.	1717	1716	1715	1714
128	m.V.	0380	0379	0378	0377
	o.V.	1717	1716	1715	1714

	R	65	75	100	125	150	200	250	300
210, 211	m.V.	1454	1299	1300	1635	1301	1302	1571	1303
	o.V.								
213	m.V.	1454	1299	1300	1635	1301	1302	1571	1303
	o.V.								
215	m.V.	1454	1299	1300	1635	1301	1302	1571	1303
	o.V.								

	R	75	100	150	200	250	300
220, 221	m.V.	394	1295	1296	1297	1596	1298
	o.V.						
223	m.V.	394	1295	1296	1297	1596	1298
	o.V.						
225	m.V.	394	1295	1296	1297	1596	1298
	o.V.						
228	m.V.	394	1295	1296	1297	1596	1298
	o.V.						

	R	75	100	150	200	250	300
240, 241	m.V.		1455	1456	1457	1458	1459
	o.V.						
243	m.V.		1455	1456	1457	1458	1459
	o.V.						
245	m.V.		1455	1456	1457	1458	1459
	o.V.						

	R	100	150	200	250	300	400
320, 321	m.V.	0421	1305	1306	1570	1307	1308
	o.V.		420	419	1569	418	417
323	m.V.	0421	1305	1306	1570	1307	1308
	o.V.		420	419	1569	418	417
325	m.V.	0421	1305	1306	1570	1307	1308
	o.V.		420	419	1569	418	417
328	m.V.	0421	1305	1306	1570	1307	1308
	o.V.		420	419	1569	418	417

	R	100	130	150	200	300	400
310, 311	m.V.		1309	1310	1311	1312	1313
	o.V.						
313	m.V.		1309	1310	1311	1312	1313
	o.V.						
315	m.V.		1309	1310	1311	1312	1313
	o.V.						

	R	100	150	200	250	300	400
340, 341	m.V.		1544	1545	1546	1547	1548
	o.V.			1543	1542	1541	1540
345	m.V.		1544	1545	1546	1547	1548
	o.V.			1543	1542	1541	1540

	R	150	200	250	300	400	500
510, 511	m.V.						
	o.V.						
513	m.V.						
	o.V.						
515	m.V.						
	o.V.						

	R	150	200	250	300	400	500
520, 521	m.V.	1094	1095	1437	109	1097	1098
	o.V.						
523	m.V.	1094	1095	1437	1096	1097	1098
	o.V.						
525	m.V.	1094	1095	1437	1096	1097	1098
	O.V.						
528	m.V.	1094	1095	1437	1096	1097	1098
	o.V.						

	R	150	200	250	300	400	500
510, 511	m.V.						
	o.V.						
513	m.V.						
	o.V.						
515	m.V.						
	o.V.						

	R	150	200	250	300	400	500
520, 521	m.V.	1094	1095	1437	109	1097	1098
	o.V.						
523	m.V.	1094	1095	1437	1096	1097	1098
	o.V.						
525	m.V.	1094	1095	1437	1096	1097	1098
	O.V.						
528	m.V.	1094	1095	1437	1096	1097	1098
	o.V.						



PKK 30 50 60 70 80 90 100 110 120 130 150 170 180 200 220 230 250 300

110	373	374	375	372	371	370	369	1815	1864	-	-	-	-	-	-	-	-	-
111	373	374	375	372	371	370	369	1815	1864	-	-	-	-	-	-	-	-	-
113	373	374	375	372	371	370	369	1815	1864	-	-	-	-	-	-	-	-	-
115	-	-	-	-	-	-	-	-	-	-	-	-	-	-	-	-	-	-
120	373	374	375	372	371	370	369	1815	1864	-	-	-	-	-	-	-	-	-
121	373	374	375	372	371	370	369	1815	1864	-	-	-	-	-	-	-	-	-
123	373	374	375	372	371	370	369	1815	1864	-	-	-	-	-	-	-	-	-
125	-	-	-	-	-	-	-	-	-	-	-	-	-	-	-	-	-	-
128	373	374	375	372	371	370	369	1815	1864	-	-	-	-	-	-	-	-	-
210	-	390	389	388	387	386	385	1517	384	1436	383	382	-	381	1887	-	-	-
211	-	390	389	388	387	386	385	1517	384	1436	383	382	-	381	1887	-	-	-
213	-	390	389	388	387	386	385	1517	384	1436	383	382	-	381	1887	-	-	-
215	-	-	-	-	-	-	-	-	-	-	-	-	-	-	-	-	-	-
220	-	390	389	388	387	386	385	1517	384	1436	383	382	-	381	1887	-	-	-
221	-	390	389	388	387	386	385	1517	384	1436	383	382	-	381	1887	-	-	-
223	-	390	389	388	387	386	385	1517	384	1436	383	382	-	381	1887	-	-	-
225	-	-	-	-	-	-	-	-	-	-	-	-	-	-	-	-	-	-
228	-	390	389	388	387	386	385	1517	384	1436	383	382	-	381	1887	-	-	-
240	-	390	389	388	387	386	385	1517	384	1436	383	382	-	381	1887	-	-	-
241	-	390	389	388	387	386	385	1517	384	1436	383	382	-	381	1887	-	-	-
243	-	390	389	388	387	386	385	1517	384	1436	383	382	-	381	1887	-	-	-
245	-	-	-	-	-	-	-	-	-	-	-	-	-	-	-	-	-	-
310	-	416	1564	1565	1164	1566	411	-	1009	1567	410	1392	1888	409	-	1889	408	407
311	-	416	1564	1565	1164	1566	411	-	1009	1567	410	1392	1888	409	-	1889	408	407
313	-	416	1564	1565	1164	1566	411	-	1009	1567	410	1392	1888	409	-	1889	408	407
315	-	-	-	-	-	-	-	-	-	-	-	-	-	-	-	-	-	-
320	-	416	1564	1565	1164	1566	411	-	1009	1567	410	1392	1888	409	-	1889	408	407
321	-	416	1564	1565	1164	1566	411	-	1009	1567	410	1392	1888	409	-	1889	408	407
323	-	416	1564	1565	1164	1566	411	-	1009	1567	410	1392	1888	409	-	1889	408	407
325	-	-	-	-	-	-	-	-	-	-	-	-	-	-	-	-	-	-
328	-	416	1564	1565	1164	1566	411	-	1009	1567	410	1392	1888	409	-	1889	408	407
340	-	416	1564	1565	1164	1566	411	-	1009	1567	410	1392	1888	409	-	1889	408	407
341	-	416	1564	1565	1164	1566	411	-	1009	1567	410	1392	1888	409	-	1889	408	407
345	-	-	-	-	-	-	-	-	-	-	-	-	-	-	-	-	-	-
510	-	416	1564	1565	1164	1566	411	-	1009	1567	410	1392	1888	409	-	1889	408	407
511	-	416	1564	1565	1164	1566	411	-	1009	1567	410	1392	1888	409	-	1889	408	407
513	-	416	1564	1565	1164	1566	411	-	1009	1567	410	1392	1888	409	-	1889	408	407
515	-	-	-	-	-	-	-	-	-	-	-	-	-	-	-	-	-	-
520	-	416	1564	1565	1164	1566	411	-	1009	1567	410	1392	1888	409	-	1889	408	407
521	-	416	1564	1565	1164	1566	411	-	1009	1567	410	1392	1888	409	-	1889	408	407
523	-	416	1564	1565	1164	1566	411	-	1009	1567	410	1392	1888	409	-	1889	408	407
525	-	-	-	-	-	-	-	-	-	-	-	-	-	-	-	-	-	-
528	-	416	1564	1565	1164	1566	411	-	1009	1567	410	1392	1888	409	-	1889	408	407

PKK parts 55

11

10

12

8

16

15

17



PKK	ASA 50	ASI 50	ASA 100	ASI 100	ASA 150	ASI 150	ASA 200	ASI 200	ASA 300	ASI 300	SH	SZR	ASK	ASL	GL
110	-	-	-	-	-	-	-	-	-	-	-	367	-	-	-
111	-	-	-	-	-	-	-	-	-	-	-	367	-	-	-
113	-	-	-	-	-	-	-	-	-	-	-	367	366	-	-
115	364	362	363	361	-	-	-	-	-	-	360	367	-	-	-
120	-	-	-	-	-	-	-	-	-	-	-	367	-	-	-
121	-	-	-	-	-	-	-	-	-	-	-	367	-	-	-
123	-	-	-	-	-	-	-	-	-	-	-	367	366	-	-
125	364	362	363	361	-	-	-	-	-	-	360	367	-	-	-
128	-	-	-	-	-	-	-	-	-	-	-	367	-	-	365
210	-	-	-	-	-	-	-	-	-	-	-	404	-	-	-
211	-	-	-	-	-	-	-	-	-	-	-	404	-	-	-
213	-	-	-	-	-	-	-	-	-	-	-	404	1597	403	-
215	401	399	400	398	487	485	888	887	-	-	397	404	-	-	-
220	-	-	-	-	-	-	-	-	-	-	-	404	-	-	-
221	-	-	-	-	-	-	-	-	-	-	-	404	-	-	-
223	-	-	-	-	-	-	-	-	-	-	-	404	1597	403	-
225	401	399	400	398	487	485	888	887	-	-	397	404	-	-	1740
228	-	-	-	-	-	-	-	-	-	-	-	404	-	-	402,1742
240	-	-	-	-	-	-	-	-	-	-	-	404	-	-	-
241	-	-	-	-	-	-	-	-	-	-	-	404	-	-	-
243	-	-	-	-	-	-	-	-	-	-	-	404	1597	403	-
245	401	399	400	398	487	485	888	887	-	-	397	404	-	-	-
310	-	-	-	-	-	-	-	-	-	-	-	434	-	-	-
311	-	-	-	-	-	-	-	-	-	-	-	434	-	-	-
313	-	-	-	-	-	-	-	-	-	-	-	434	1622	433	-
315	-	-	428	426	427	425	491	489	492	490	424	434	-	-	-
320	-	-	-	-	-	-	-	-	-	-	-	434	-	-	-
321	-	-	-	-	-	-	-	-	-	-	-	434	-	-	-
323	-	-	-	-	-	-	-	-	-	-	-	434	1622	433	-
325	-	-	428	426	427	425	491	489	492	490	424	434	-	-	1741
328	-	-	-	-	-	-	-	-	-	-	-	434	-	-	430,432,1632
340	-	-	-	-	-	-	-	-	-	-	-	434	-	-	-
341	-	-	-	-	-	-	-	-	-	-	-	434	-	-	-
345	-	-	428	426	427	425	491	489	492	490	424	434	-	-	-
510	-	-	-	-	-	-	-	-	-	-	-	1474	-	-	-
511	-	-	-	-	-	-	-	-	-	-	-	1474	-	-	-
513	-	-	-	-	-	-	-	-	-	-	-	1474	-	-	-
515	-	-	-	-	1399	1400	1401	1402	-	-	1478	1474	-	-	-
520	-	-	-	-	-	-	-	-	-	-	-	1474	-	-	-
521	-	-	-	-	-	-	-	-	-	-	-	1474	-	-	-
523	-	-	-	-	-	-	-	-	-	-	-	1474	1622	433	-
525	-	-	-	-	1399	1400	1401	1402	-	-	1478	1474	-	-	-
528	-	-	-	-	1399	1400	1401	1402	-	-	1478	1474	-	-	1800, 1801

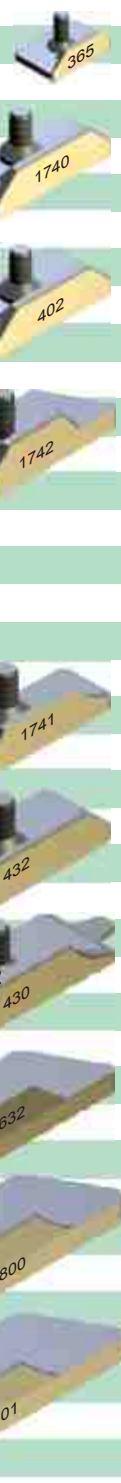

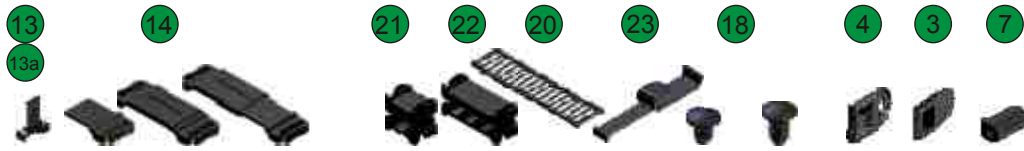

PKK PZ PTF PT55 PT75 LL25 LL50 LS HS FK SK UFA B / Z SFA

110	368	-	-	-	-	-	-	-	-	-	-	-	-	-
111	368	-	-	-	-	-	-	-	-	-	-	-	-	-
113	368	-	-	-	-	-	-	-	-	-	-	-	-	-
115	359	-	-	-	-	-	-	-	-	-	-	-	-	-
120	368	-	-	-	-	-	-	-	-	-	-	-	-	1435
121	368	-	-	-	-	-	-	-	-	-	-	-	-	1435
123	368	-	-	-	-	-	-	-	-	-	-	-	-	1435
125	359	-	-	-	-	-	-	-	-	-	-	-	-	1435
128	368	-	-	-	-	-	-	-	-	-	-	-	-	1435
210	405	879	879	880	1663	1664	1665	1847	1269	-	1467	1667	-	-
211	405	879	879	880	1663	1664	1665	1847	1269	-	1467	1667	-	-
213	405	879	879	880	1663	1664	1665	1847	1269	-	1467	1667	-	-
215	396	879	879	880	1663	1664	1665	-	1269	-	1467	1667	-	-
220	405	879	879	880	1663	1664	1665	1847	-	1366	1467	1667	1433	-
221	405	879	879	880	1663	1664	1665	1847	-	1366	1467	1667	1433	-
223	405	879	879	880	1663	1664	1665	1847	-	1366	1467	1667	1433	-
225	396	879	879	880	1663	1664	1665	-	-	1366	1467	1667	1433	-
228	405	879	879	880	1663	1664	1665	1847	-	1366	1467	1667	1433	-
240	1461	879	879	880	1663	1664	1665	1847	1269	-	-	-	-	-
241	1461	879	879	880	1663	1664	1665	1847	1269	-	-	-	-	-
243	1461	879	879	880	1663	1664	1665	1847	1269	-	-	-	-	-
245	1463	879	879	880	1663	1664	1665	-	1269	-	-	-	-	-
310	423	879	879	880	1663	1664	1665	1848	1317	-	1468	1666	-	-
311	423	879	879	880	1663	1664	1665	1848	1317	-	1468	1666	-	-
313	423	879	879	880	1663	1664	1665	1848	1317	-	1468	1666	-	-
315	422	879	879	880	1663	1664	1665	-	1317	-	1468	1666	-	-
320	423	879	879	880	1663	1664	1665	1848	-	1365	1468	1666	1434	-
321	423	879	879	880	1663	1664	1665	1848	-	1365	1468	1666	1434	-
323	423	879	879	880	1663	1664	1665	1848	-	1365	1468	1666	1434	-
325	423	879	879	880	1663	1664	1665	-	-	1365	1468	1666	1434	-
328	423	879	879	880	1663	1664	1665	1848	-	1365	1468	1666	1434	-
340	1549	879	879	880	1663	1664	1665	1848	1317	-	-	-	-	-
341	1549	879	879	880	1663	1664	1665	1848	1317	-	-	-	-	-
345	1654	879	879	880	1663	1664	1665	-	1317	-	-	-	-	-
510	1067	879	879	880	1663	1664	1665	1848	1317	-	-	-	-	-
511	1067	879	879	880	1663	1664	1665	1848	1317	-	-	-	-	-
513	1067	879	879	880	1663	1664	1665	1848	1317	-	-	-	-	-
515	1477	879	879	880	1663	1664	1665	-	1317	-	-	-	-	-
520	1067	879	879	880	1663	1664	1665	1848	1317	-	-	-	1434	-
521	1067	879	879	880	1663	1664	1665	1848	1317	-	-	-	1434	-
523	1067	879	879	880	1663	1664	1665	1848	1317	-	-	-	1434	-
525	1477	879	879	880	1663	1664	1665	-	1317	-	-	-	1434	-
528	1067	879	879	880	1663	1664	1665	1848	1317	-	-	-	1434	-

PLE

- PLE applications 67
- PLE dimensions 68
- PLE types 69
- PLE sizes 71
- PLE parts 72
- PLE assembly 73
- PLE part numbers 76



closed + open

PLE CHARACTERISTICS

The PLE with aluminum stays is available as **PLE** with plastic inserts or plastic slot profile, as **PLS** with foam slot profile or as **PLP** with plastic divider PZ.

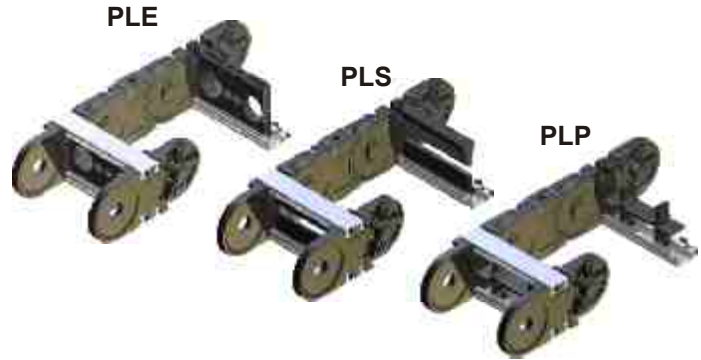

- positive stay locking
- both inside and outside radius can be opened
- simple to shorten or lengthen
- stepless stay length up to 1000 mm

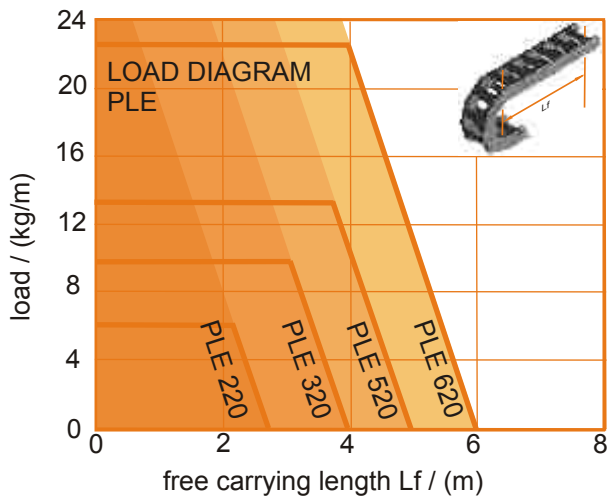

All ekd plastic energy chains are equipped with the **integrated connector**. Additional components for mounting the energy chain are not required.

Travel

The maximum travel is determined by the arrangement and the additional weight (line weight). At normal arrangement the maximum travel is twice the free carrying length. Support rollers or similar constructive steps can increase this value.

In gliding arrangements travel distances up to 100 meters are possible.

Longer travel distances need further constructive steps, like SYSTEM MARATHON, which exceeds the travel distance nearly without limits.

Travel speed

There are no limits for the travel speed in general. But in gliding applications specific influences have to be taken into account.

Acceleration

In principle there are no restrictions for the acceleration. Limits can only be achieved at high tension forces caused by high additional weights.

Temperature

The operating temperature is inbetween -20 °C and 100 °C.

Special versions

- | | |
|----------|------------------------|
| ALLROUND | ... all movements |
| ATEX | ... EX-protection |
| ESD | ... antistatic |
| V-0 | ... self extinguishing |

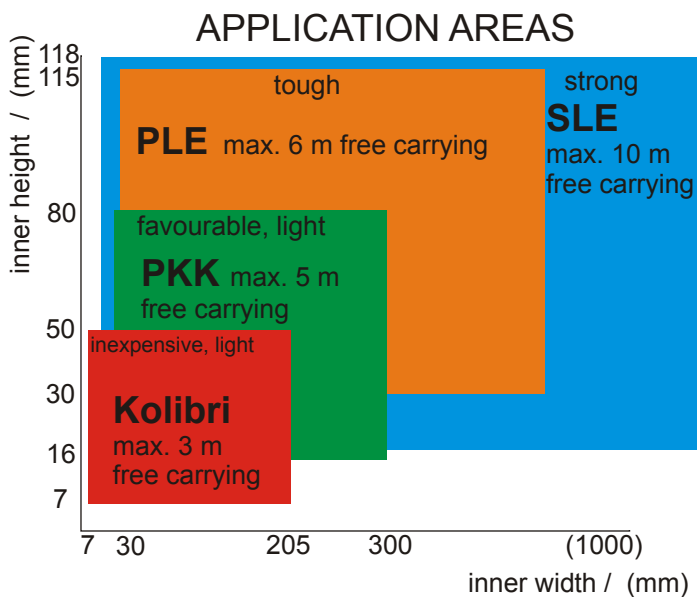



**Machine tools,
Handling technology,
Conveying and lifting equipment**



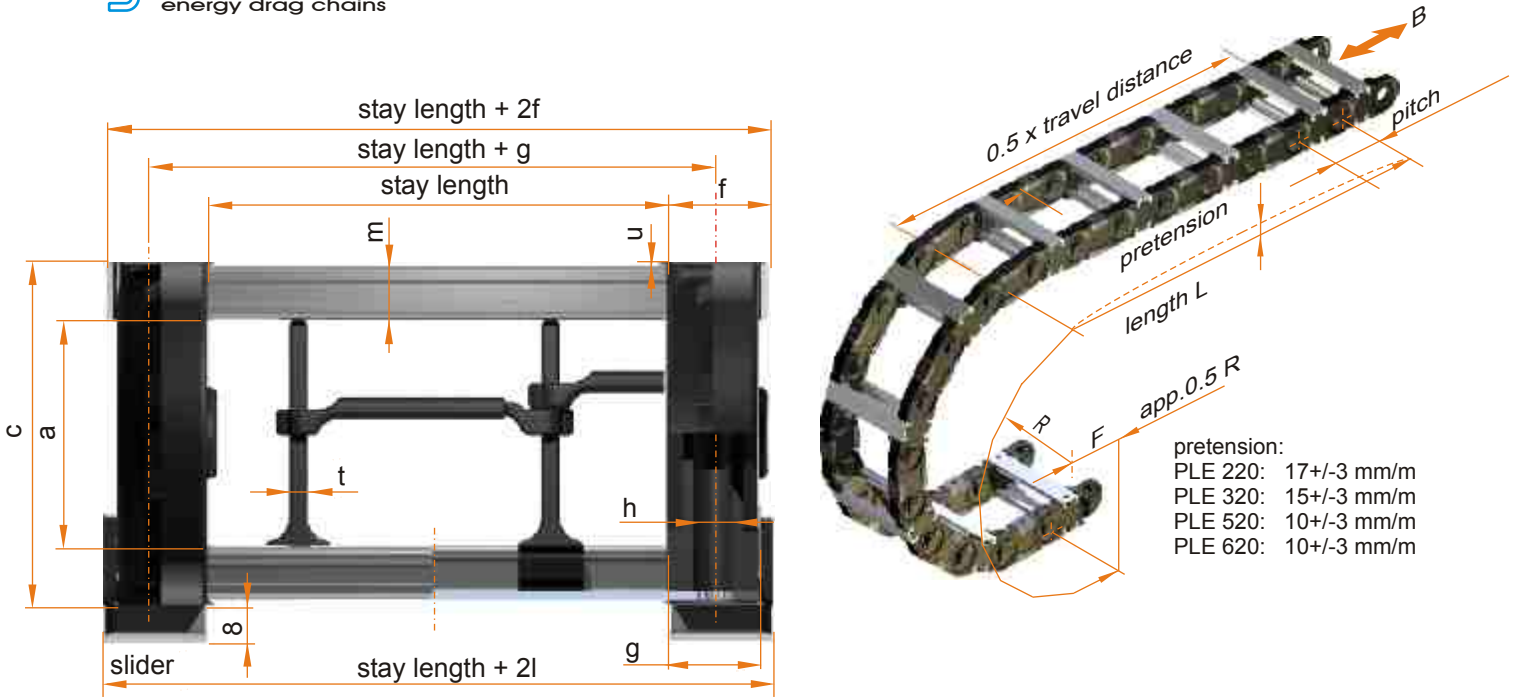

pretension:
 PLE 220: 17+/-3 mm/m
 PLE 320: 15+/-3 mm/m
 PLE 520: 10+/-3 mm/m
 PLE 620: 10+/-3 mm/m

The usable interior width is stay length - 2 mm

PLE	bending radius R [mm]	pitch	a	c	f	g	h	l ¹⁾	m	t	u	weight [kg/m] ³⁾
220, 221	75 100 150 200 300	75	31	50	18	16	Ø6	-	9	4	1	1.9
320, 321, 325, 328 ²⁾	150 200 250 300 400	100	49	75	22	20	Ø8	18	12	4	1	3.4 (4.4)
520, 521, 525, 528 ²⁾	200 250 300 400 500	125	68	100	26	24	Ø8	21	15	4	1	4.8 (5.9)
541, 548 ²⁾	200 250 300 400 500	125	80	100	26	24	Ø8	21	9	4	1	4.60
620, 621	230 300 400 500 700	187	115	150	32	32	Ø10	-	15	8	2	7.20

1) stay length + 2l is the outside width, including sliders 2) PLE 328 from R200, PLE 528, 548 from R250
 3) weight with stay length 100, values in brackets for closed version

The stay lengths are offered in steps of 1 mm.

PLE	minimum stay length [mm]	maximum stay length [mm]	PLE inserts Ø [mm]															
			10	15	20	25	30	35	40	45	50	55	60	65	70			
220, 221	50	800																
320, 321, 325, 328	60	900																
520, 521, 525, 528	70	1000																
541, 548	70	900																
620, 621	90	1000																

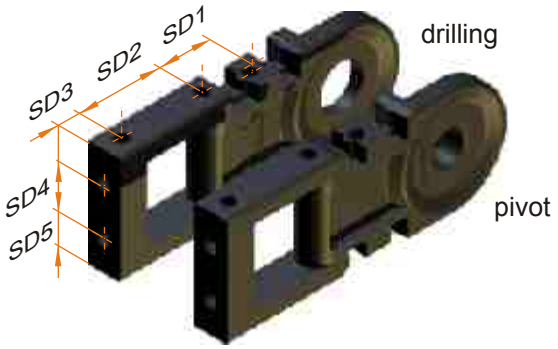

PLE SD- connector	SD1	SD2	SD3	SD4	SD5
220, 221, 225	22,5	37,5	8,5	22	7,5
320, 321, 325, 328	35	45	8,5	45	15
520, 521, 525, 528	35	45	8,5	66	17

order example: travel distance 3 m, bending radius 200 mm, cable: 1x15 mm, 8x8 mm, 3x12 mm, 2x22 mm, chain arrangement is hanging

PLE 320 / 200	x	2325	/ 200	/ SD 32, SD 32 /	h	/ 5 PZ, 1 Pt55
type / radius	x	length	/ stay length /	connectors /	arrangement /	stay distribution

PLE energy chains are distinguished from standard plastic chains by their extreme stability and the rigid, continuously adjustable aluminum profile. Stay lengths up to 1000 mm can be accommodated.

The allocation of the interior offers variable opportunities and guarantees optimum line protection even at high acceleration and travel speed.

The **PLE** (PLE with plastic inserts or plastic insert-profile) ensures a perfect guide at high speeds. Errors during installation of the cables are nearly impossible, with this variation, the hole design of the stays meet exactly the requirements of the lines. Plastic inserts are available in 5 mm steps. The plastic insert-profile can be ordered according to drawing.

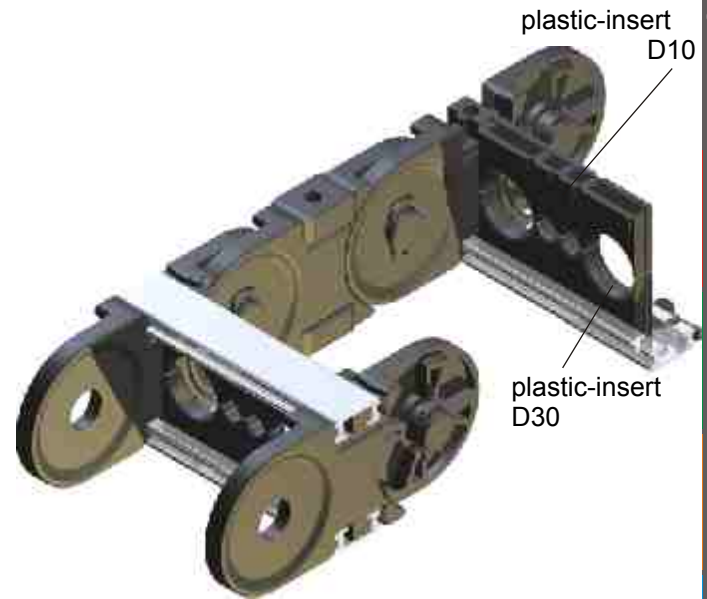

In case of limited installation space, the **PLS** (PLE with foam insert-profile) are used. Again, the optimal guiding of the lines at high speeds and acceleration is ensured. All lines are in the neutral axis (middle of chain height).

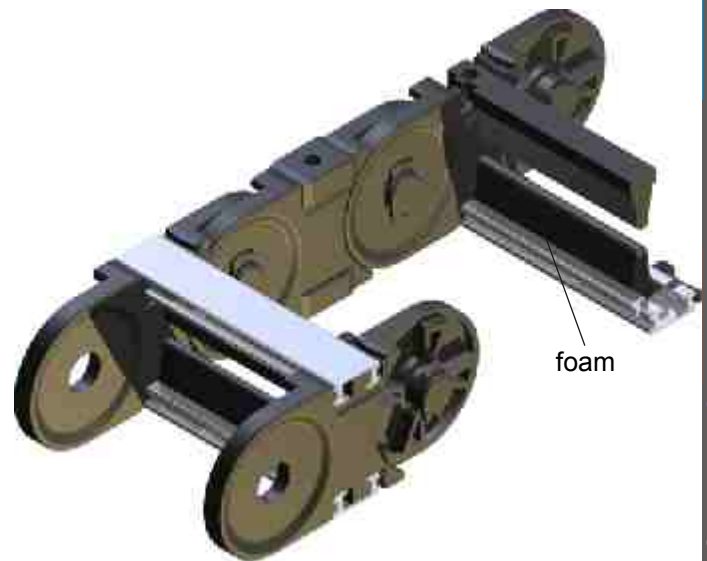

For space reasons the **PLP** (PLE with plastic dividers) may be chosen. This inexpensive design allows secure guiding of large amounts of cable. The highly variable stay distribution opportunities through the small steps (3mm) in height and the infinitely adjustable plastic telescopic dividers (PT) allow maximum space for all needs, even when changes in cable diameters are required.

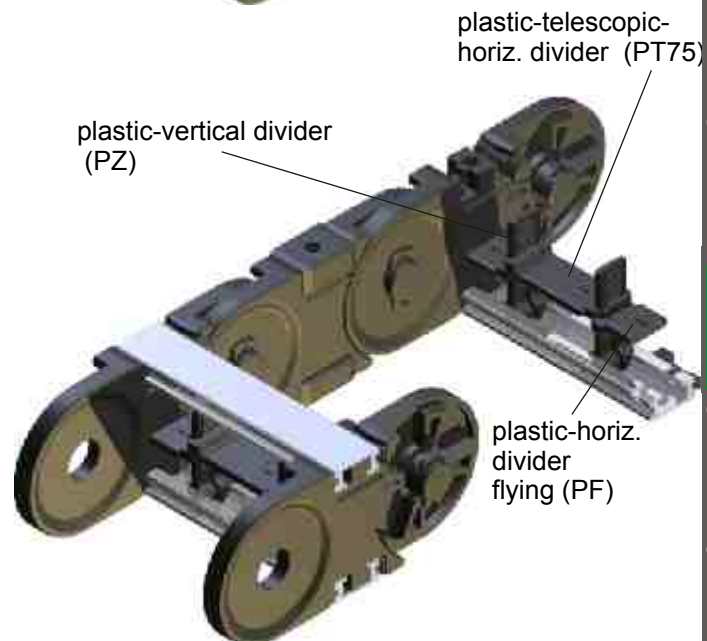

PLE 220, 320, 520, 620

The standard type is build with stays in every second chain link. The **integrated connector** makes every link in the chain when needed to a connector (not 620) and therefore the separate ordering and storage of end connector brackets is not necessary.

order example:

PLE 220	/ 100	x 3525	/ 100
type	radius	length	stay length

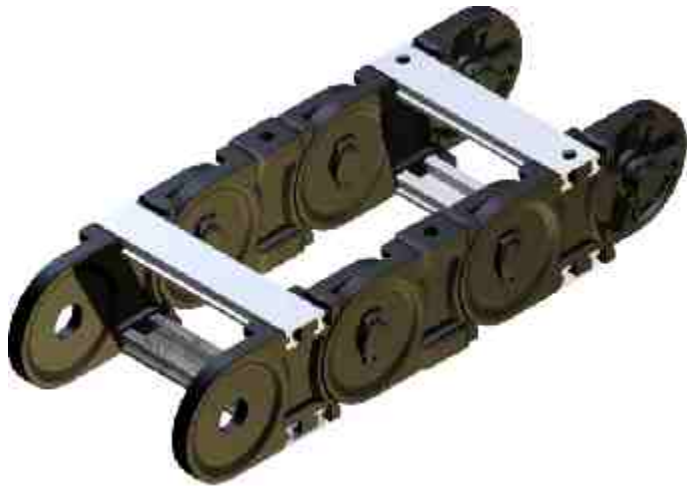

PLE 221, 321, 521, 541, 621

These designs are made with stays in each link. This increases the lateral stability and improves the guiding particularly of smaller diameter lines.

order example:

PLE 221	/ 100	x 3525	/ 100
type	radius	length	stay length

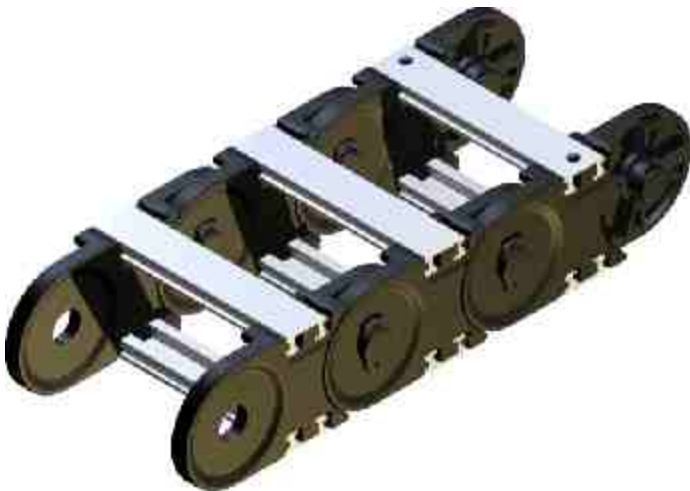

PLE 325, 525

The closed types with aluminum covers may also replace the standard version stay. The covers can be opened in the inner or outer radius.

order example:

PLE 325	/ 300	x 3500	/ 100
type	radius	length	stay length

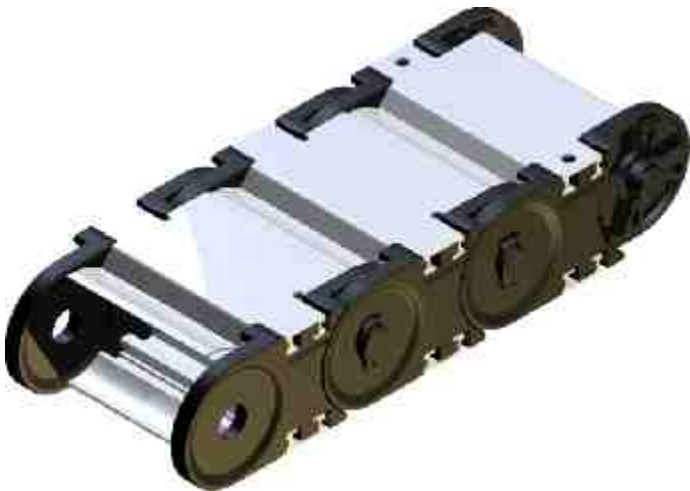

PLE 328, 528, 548

These types are suitable for long travel, the upper strand slides on the lower strand. For increased stability these energy chains are also build with stays in each link. The energy chains are fitted with sliders in the inner radius, which have a very low coefficient of friction ($\mu = 0.2$ to 0.25). After reaching the wear limit, the slider can be renewed and the energy chain will continue. Subsequent slider assembly is also possible. Then, the stays must be provided with drilled location holes.

order example:

PLE 328	/ 200	x 3500	/ 100
type	radius	length	stay length

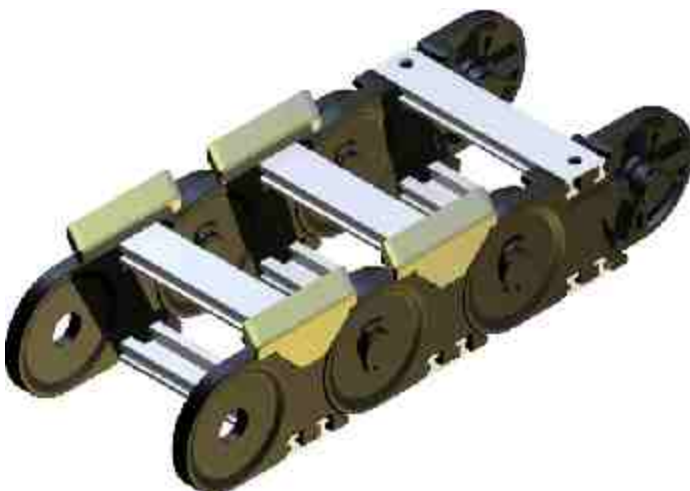

PLE 220

standard type

height: 50 width: 86 ... 836
inner height: 31 inner width: 50 ... 800

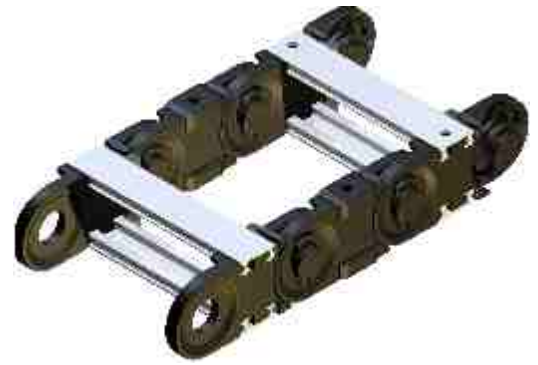

PLE 320

standard type

height: 75 width: 104 ... 944
inner height: 49 inner width: 60 ... 900



PLE 520

standard type

height: 100 width: 122 ... 1052
inner height: 68 inner width: 70 ... 1000

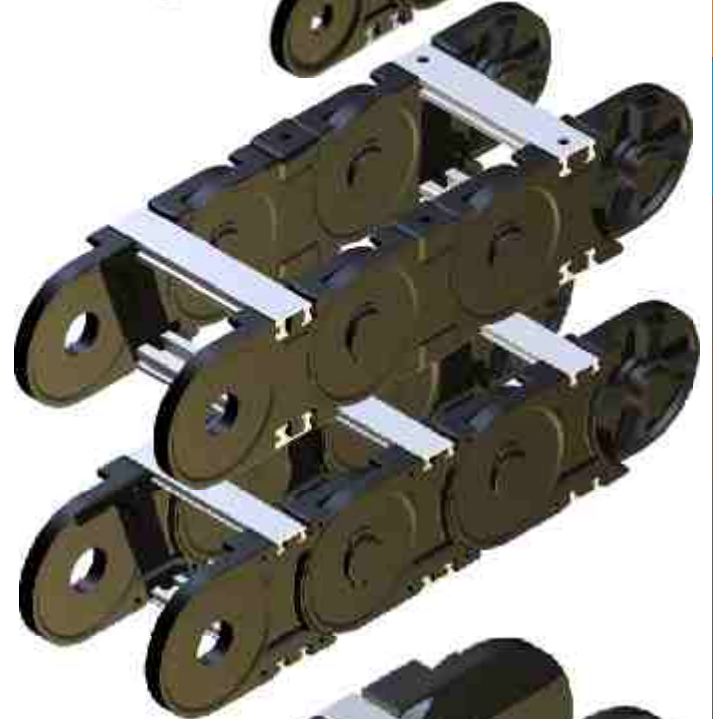

PLE 541

stay in each link

height: 100 width: 122 ... 1052
inner height: 80 inner width: 70 ... 1000

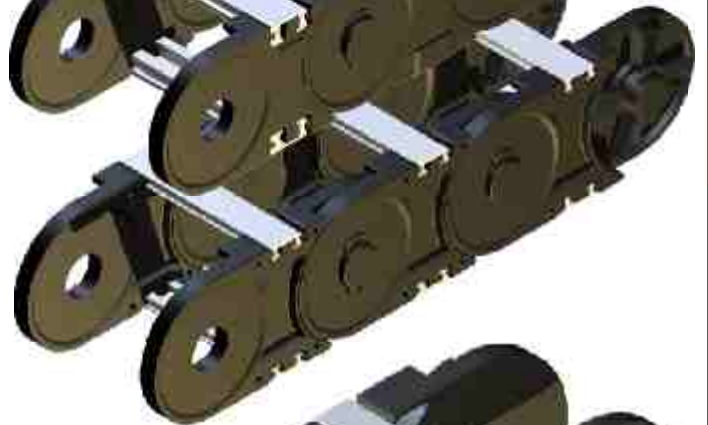

PLE 620

standard type

height: 150 width: 154 ... 1064
inner height: 115 inner width: 90 ... 1000

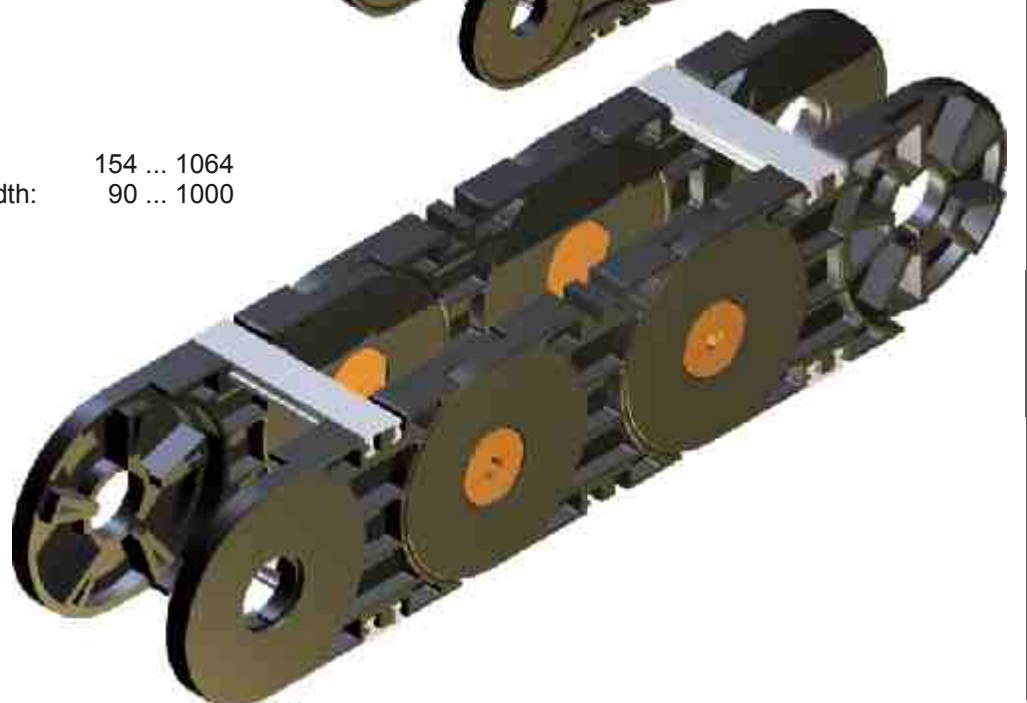

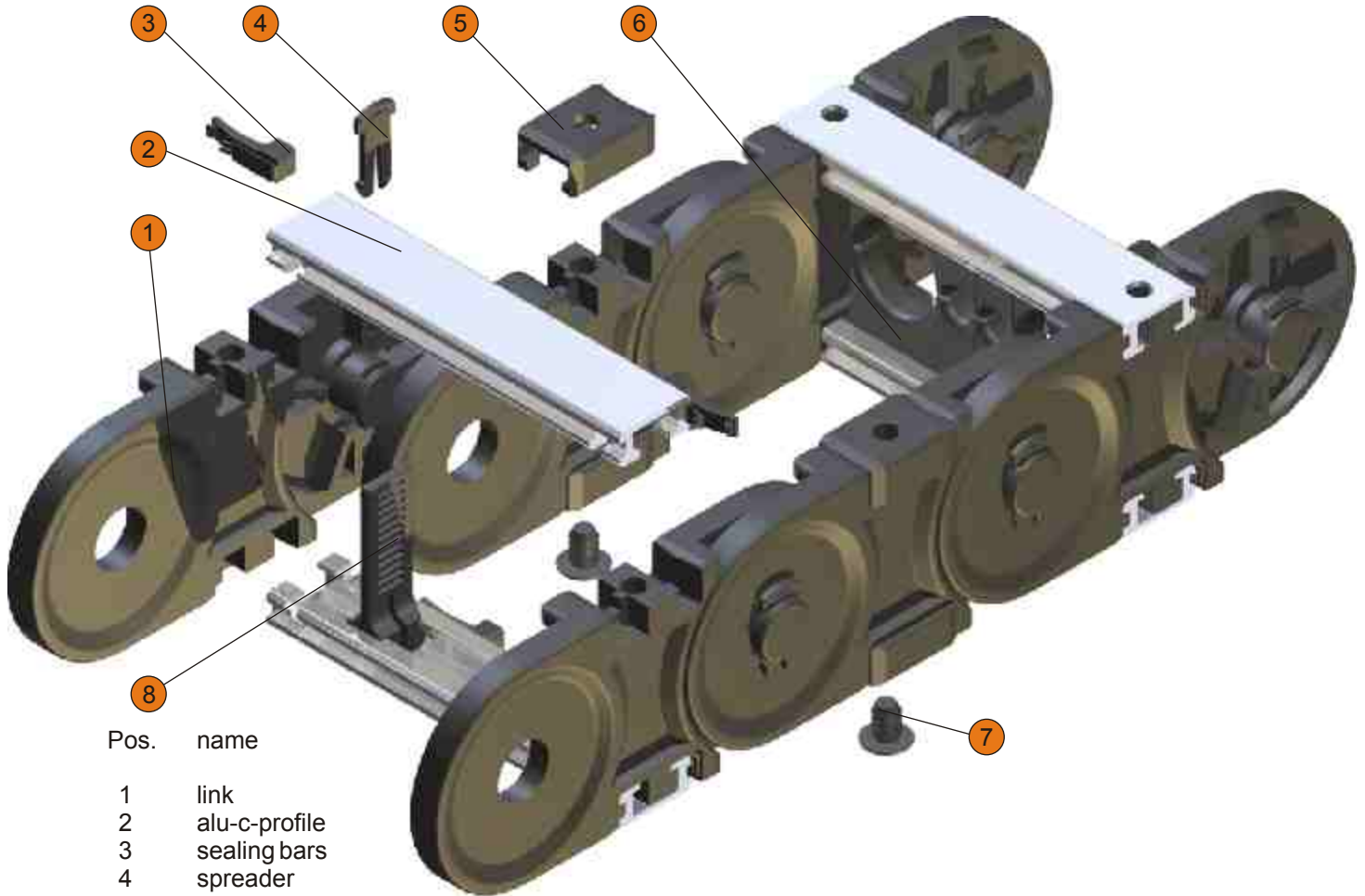

Pos.	name
1	link
2	alu-c-profile
3	sealing bars
4	spreader
5	filler
6	insert
7	damping element
8	plastic vertical divider (PZ)
9	inner cover
10	outer cover

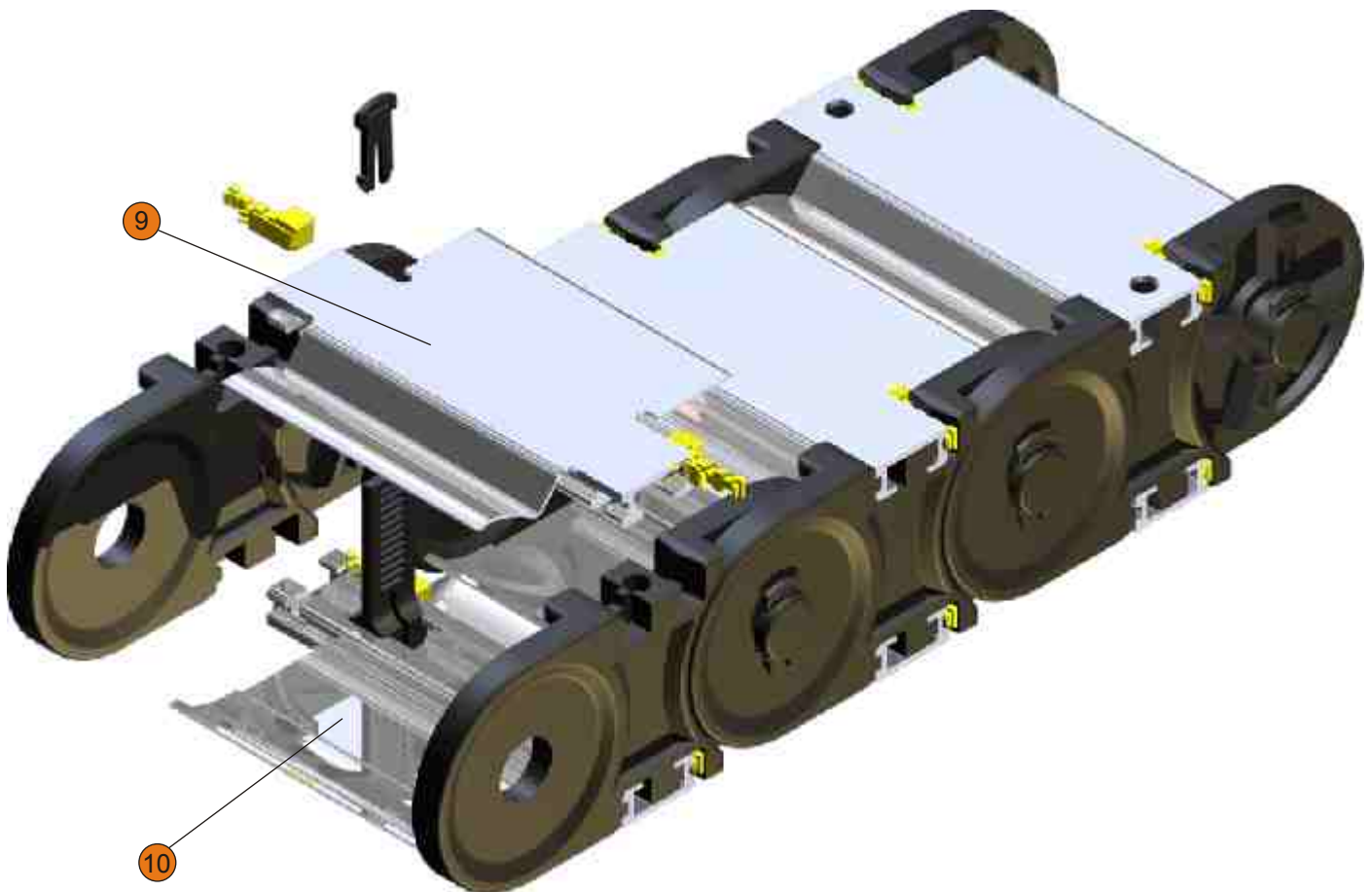

Lengthening or shortening, link bands

To shorten the spreaders are disengaged (1), taken from (2,3) and the corresponding piece of chain removed (4). Lengthening is done by adding links and inter-lock with the spreaders.

Alternatively, first part of strands assembled or dismantled. Then a stay assembly or disassembly is required.

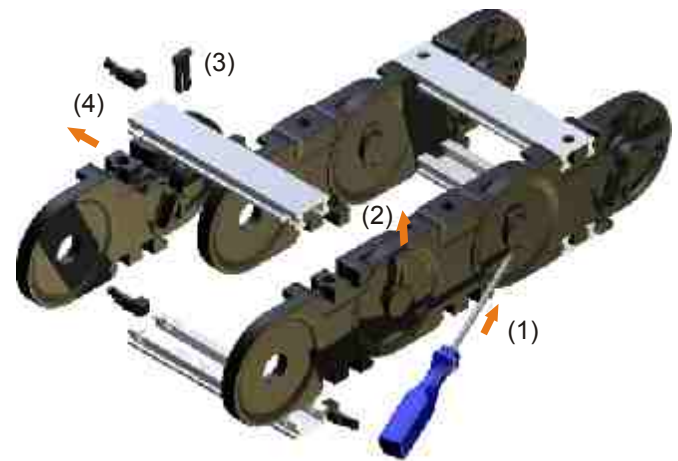

Stay assembly

Stays are installed (1) and locked by horizontal shifting into place (2). Then pushing the sealing bars outside until they lock the link.

Stay disassembly

Push sealing bar to the inside (4), unlock stay (5) and remove them (6).

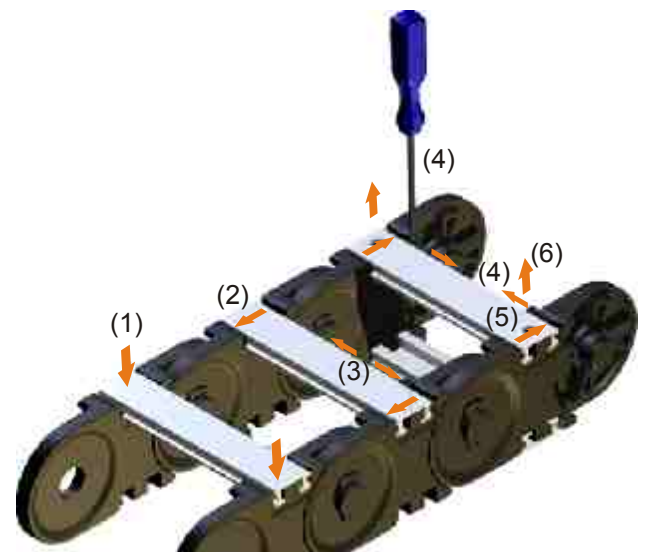

Filler

The fillers are mounted in the recess and (possibly with a light plastic hammer) pushed until locked (1).

The dismantling of the fillers is done with a screwdriver. The screwdriver blade ought to be small enough to start behind the filler. Then unhinge the filler (2).

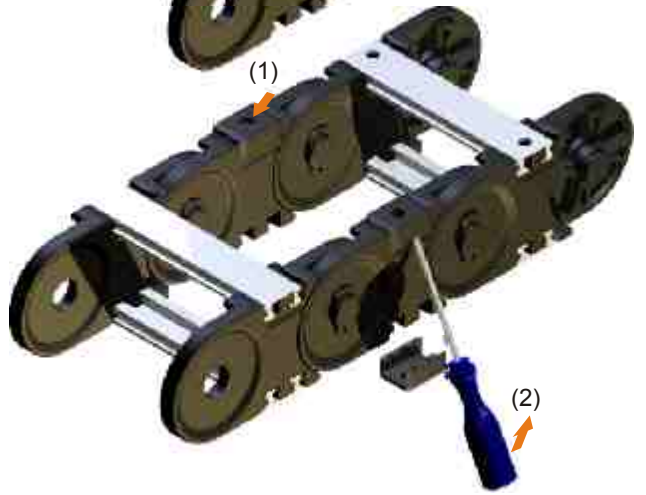

Covers

The assembly of the covers is the same as the assembly and disassembly of the stays. The sealing bar is positioned in the designated position with a screwdriver.

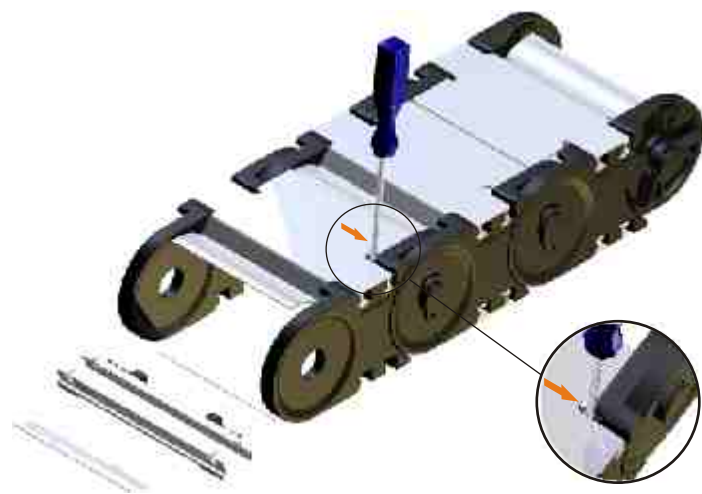

Plastic inserts

The inserts are assembled according to the required lateral position (1) and inserted into the stay (2).

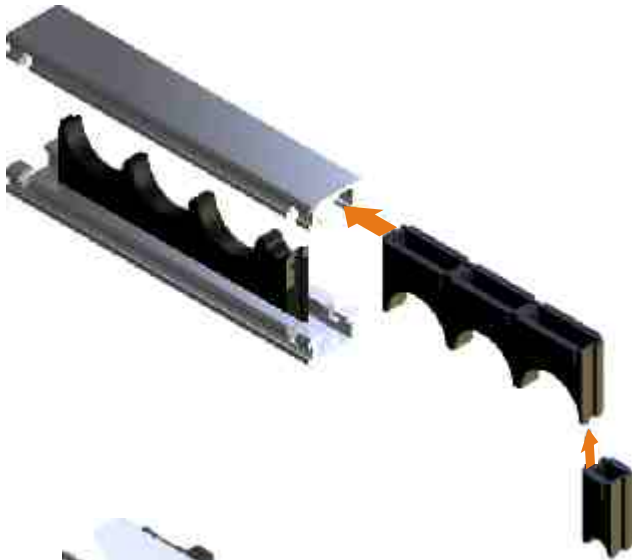

Foam

The foam insert is pushed laterally into the aluminum-profile (1), before they are assembled to the chain links.



Plastic divider PZ

The plastic dividers are hooked into the desired position with the long side of the foot in the aluminum bar and engaged with slight pressure (1).

Corrections of the position by lateral displacement are possible. The dismantling of the PZ is done by pulling in the opposite direction or sideways push out from the stay.

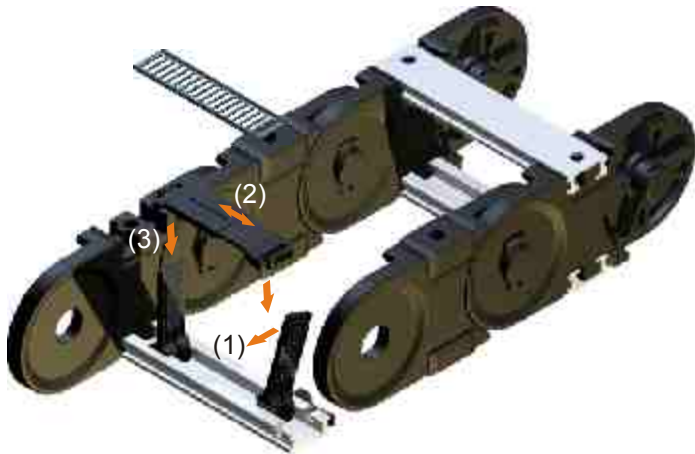

Telescopic horizontal divider

The telescopic horizontal divider can be adjusted in length (2), vertically fitted on the PZ (3) and engaged in the designated height.

The dismantling is carried out with a screwdriver by unlocking and removal.

Mounting the energy chain

All ekd plastic energy chains are equipped with **integrated connectors**. They allow the mounting of the energy chain with any link.

In gliding energy chain applications or for a smooth optical effect, the mounting holes in the fixed connector can be countersunk.

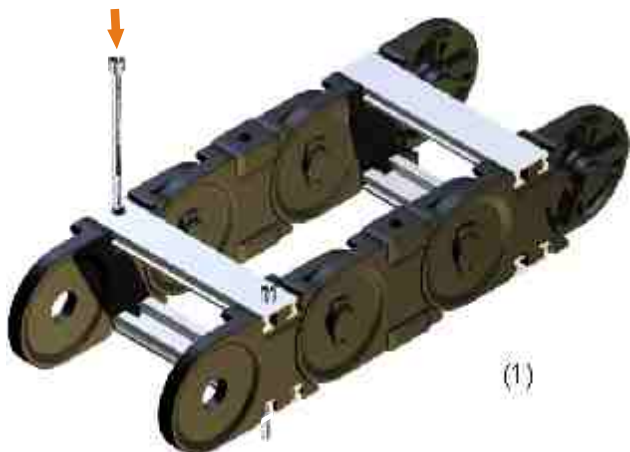

Face mounting

The energy chain PLE can be optionally fitted with flange connectors. The flange connectors allow various mounting opportunities, mounted like chain links and secured with a stay.

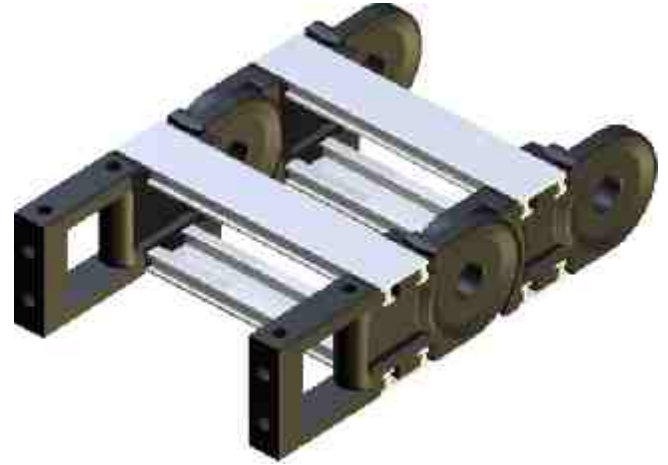

Sliders

To avoid damage the slider must be conditioned (overnight storage in water at room temperature or 2 h at 80 ° C).

The slider is positioned at the inner radius of the energy chain, with the pin in the bore of the stay (1) and pushed until the snap hook locks (2).

To dismantle unhinge the snap hook (3) and remove the slider to the top (4).

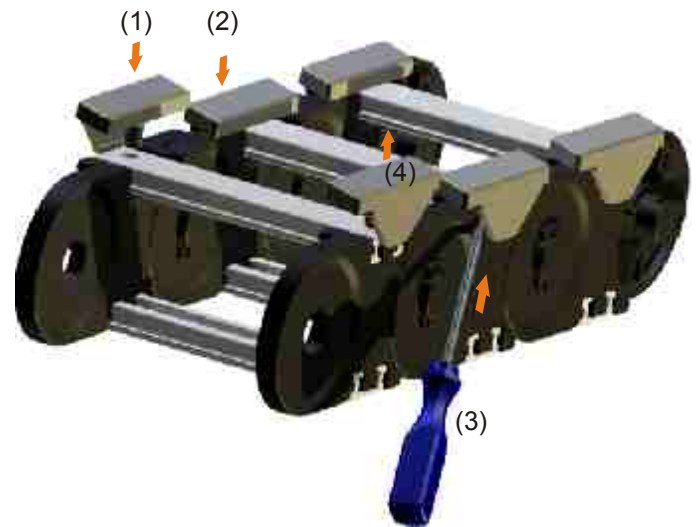

The implementation of an energy chain with sliders has to be done smoothly. In addition, the glide bars (1) should be fitted with contour at the end of the energy chain and counter sinking the connector screws (2). The distance between the glide bar to the first slider should be less than the slider length (3).

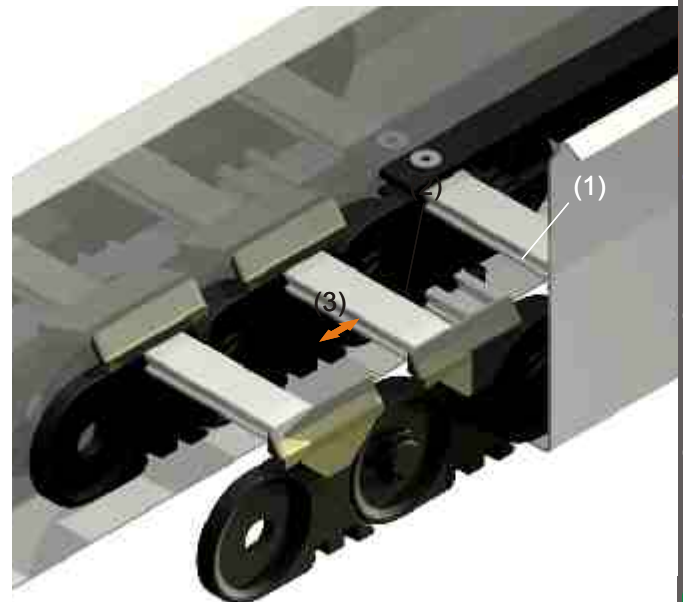

Maintenance of the energy chain

PLE energy chains are maintenance free. Like every mechanical system this will depend on the ambient conditions so wear will occur which must be observed.

In case of the energy chain has to be replaced.

For long travels or in a circular motion, the energy chains are often equipped with sliding elements. These allow sliding of the upper part of the chain on a suitable surface (eg, slider-slider, slider-steel, glide bar).

The sliders wear depends on the application. The slider surfaces should be checked at regular intervals. With a thickness of 1-2 mm sliders have to be replaced.

1



PLE	link					
	R	75	100	150	200	300
220	m.V.	0346	1190	1219	1191	1192
	o.V.	1193	1194	1218	1195	1196
221	m.V.	0346	1190	1219	1191	1192
	o.V.	1193	1194	1218	1195	1196
	R	150	200	250	300	400
320	m.V.	0351	1197	1198	1199	1200
	o.V.	1201	1202	1203	1204	1205
321	m.V.	0351	1197	1198	1199	1200
	o.V.	1201	1202	1203	1204	1205
325	m.V.	0351	1197	1198	1199	1200
	o.V.	1201	1202	1203	1204	1205
328	m.V.	0351	1197	1198	1199	1200
	o.V.	1201	1202	1203	1204	1205
	R	200	250	300	400	500
520	m.V.	0944	1206	1207	1208	1209
	o.V.	1211	1212	1213	1214	1215
521	m.V.	0944	1206	1207	1208	1209
	o.V.	1211	1212	1213	1214	1215
525	m.V.	0944	1206	1207	1208	1209
	o.V.	1211	1212	1213	1214	1215
528	m.V.	0944	1206	1207	1208	1209
	o.V.	1211	1212	1213	1214	1215
	R	200	250	300	400	500
541	m.V.	1611	1607	1608	1609	1610
	o.V.	xxxx	xxxx	xxxx	xxxx	xxxx
548	m.V.	1611	1607	1608	1609	1610
	o.V.	Xxxx	xxxx	xxxx	xxxx	xxxx
	R	230	300	400	500	700
620	m.V.	1104	1100	1101	1102	1103
	o.V.	-	-	-	-	-
621	m.V.	1104	1100	1101	1102	1103
	o.V.	-	-	-	-	-

PLE PART NUMBERS

4



5



7



2



3



10

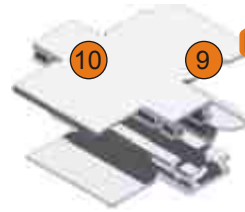

9

PLE parts

72

PLE

SR

PS

FK

C-profile

SRR/SRR5

ASA

ASI

foam

220	0348	0345	1269	0976	0344		-	-	0730
221	0348	-	1269	0976	0344		-	-	0730

320	0353	0350	1317	0977	0349		-	-	0731
321	0353	-	1317	0977	0349		-	-	0731
325	0353	-	1317	-	1668 1669		1640	1638	0731
328	0353	-	1317	0977	0349		-	-	0731

520	0358	0943	1317	0978	0942		-	-	0732
521	0358	-	1317	0978	0942		-	-	0732
525	0358	-	1317	-	1656 1657		1641	1639	0732
528	0358	-	1317	0978	0942		-	-	0732

541	0358	-	1269	0976	1676		-	-	-
548	0358	-	1269	0976	1676		-	-	-

hub



connector angle



cover connector angle



left right

620	1109	-	-	0978	1328		1630	1629	1631
621	1109	-	-	0978	1328		1630	1629	1631

PLE parts 72

8



PLE	PZ	PTF	PT 55	PT 75	LL 25	LL 50	LS	GL	SDA Drilling Pin
-----	----	-----	-------	-------	-------	-------	----	----	---------------------

220	0778	1519	0879	0879	0880	1663	1664	1421	-	1439 1761
221	0778	1519	0879	0879	0880	1663	1664	1421	-	1439 1761



320	0163	1678	0879	0879	0880	1663	1664	1421	-	1773 1774
321	0163	1678	0879	0879	0880	1663	1664	1421	-	1773 1774
325	0163	1678	0879	0879	0880	1663	1664	1421	1450	1773 1774
328	0163	1678	0879	0879	0880	1663	1664	1421	1450	1773 1774



520	0719	1680	0879	0879	0880	1663	1664	1421	-	1775 1776
521	0719	1680	0879	0879	0880	1663	1664	1421	-	1775 1776
525	0719	1680	0879	0879	0880	1663	1664	1421	1449	1775 1776
528	0719	1680	0879	0879	0880	1663	1664	1421	1449	1775 1776



541	1613		0879	0879	0880	1663	1664	1421	-	
548	1613		0879	0879	0880	1663	1664	1421	1449	



620	1257	1110	-	-	-	-	-	-	-	
621	1257	1110	-	-	-	-	-	-	-	

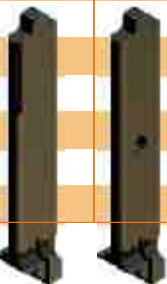

PLE PART NUMBERS

inserts

diameter in mm

PLE

10 15 20 25 30 35 40 45 50 55 60 65 70



220	649	650	651	652	653	-	-	-	-	-	-	-	-
221	649	650	651	652	653	-	-	-	-	-	-	-	-



320	654	665	656	657	658	659	660	661	662	-	-	-	-
321	654	665	656	657	658	659	660	661	662	-	-	-	-
325	654	665	656	657	658	659	660	661	662	-	-	-	-
328	654	665	656	657	658	659	660	661	662	-	-	-	-



520	1628	663	664	665	666	667	668	669	670	671	672	714	715
521	1628	663	664	665	666	667	668	669	670	671	672	714	715
525	1628	663	664	665	666	667	668	669	670	671	672	714	715
528	1628	663	664	665	666	667	668	669	670	671	672	714	715

541	-	-	-	-	-	-	-	-	-	-	-	-	-
-----	---	---	---	---	---	---	---	---	---	---	---	---	---

548	-	-	-	-	-	-	-	-	-	-	-	-	-
-----	---	---	---	---	---	---	---	---	---	---	---	---	---

620	-	-	-	-	-	-	-	-	-	-	-	-	-
-----	---	---	---	---	---	---	---	---	---	---	---	---	---

621	-	-	-	-	-	-	-	-	-	-	-	-	-
-----	---	---	---	---	---	---	---	---	---	---	---	---	---

SLE

SLE applications	81
SLE dimensions	82
SLE types	84
SLE sizes	86
SLE parts	87
SLE assembly	88
SLE connectors	83
SLE part numbers	92
SLE accessories	98

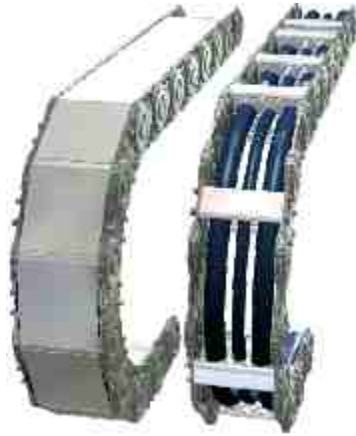

closed + open

SLE CHARACTERISTICS

The SLE is available as **SLA** with aluminium T- or slot-profile, as **SLE** with plastic inserts or plastic slot profile, as **SLS** with foam slot profile, as **SLP** with plastic divider PZ or as **SLR** with pipe or roll stays.



In steel, stainless steel and hardened material is the steel chain in case of large free carrying lengths, large quantities of cables and heavy-duty hydraulic hoses first choice.

- stay distributions in many variants
- stay fast assembly and disassembly
- simple shortening and lengthening
- shroud protecting pivot mechanics

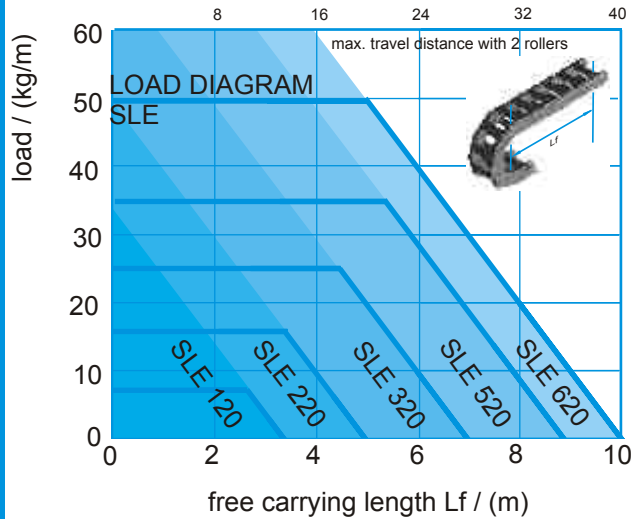

Travel

The maximum travel distance is determined by the arrangement and the additional weight (line weight). At normal arrangement the maximum travel is twice the free carrying length. Support rollers or similar constructive steps can increase this value.

In gliding arrangement travel distances up to 100 meters are possible (application dependent). Exceeding this value additional constructive action is needed (see design guidelines).

Travel speed

The standard and the stainless steel design is limited at 1m/s. Exceeding this and high dynamic loads caused by e.g. vibrations or high number of cycles require the use of the hardened (carburised) material.

Acceleration

The acceleration in principle is not limited. Limits are achieved, by very long chains and line weight that cause extreme tensile forces.

Temperature

The long term operating temperature is -20 °C to 600 °C (-40 °C stainless steel to 600 °C).

Special types

- Stainless Steel
- Carburised (hardened)



application fields

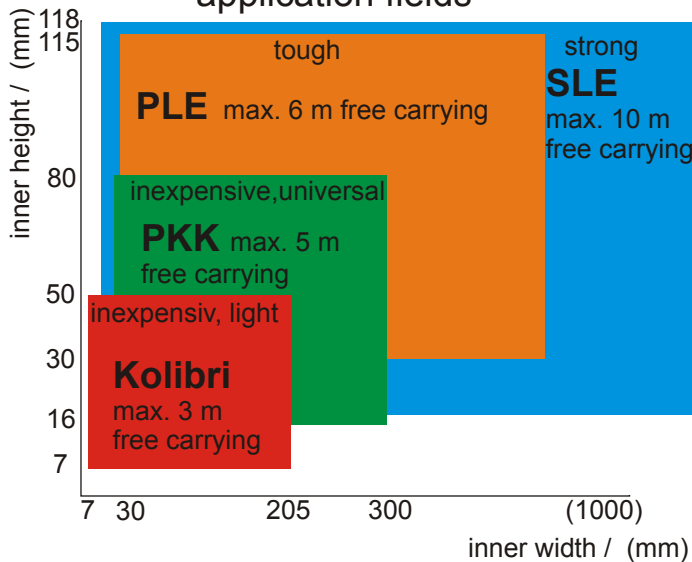

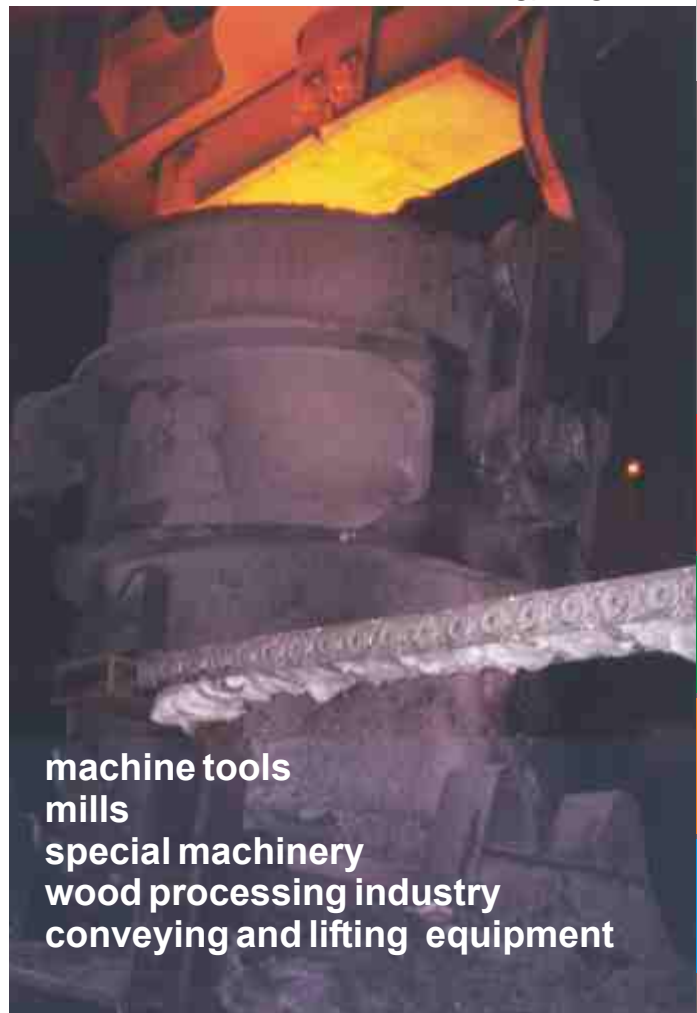

machine tools
mills
special machinery
wood processing industry
conveying and lifting equipment



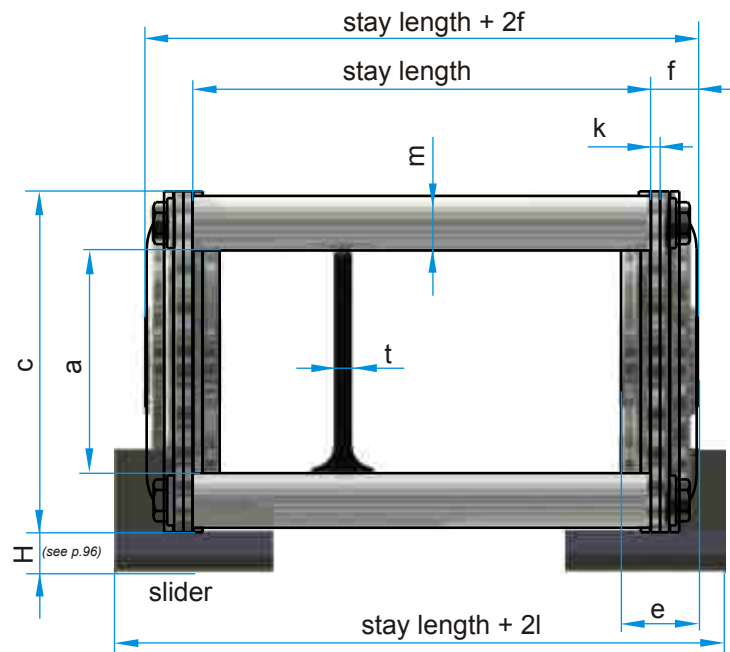

the usable interior width is stay length - 2(e-f)

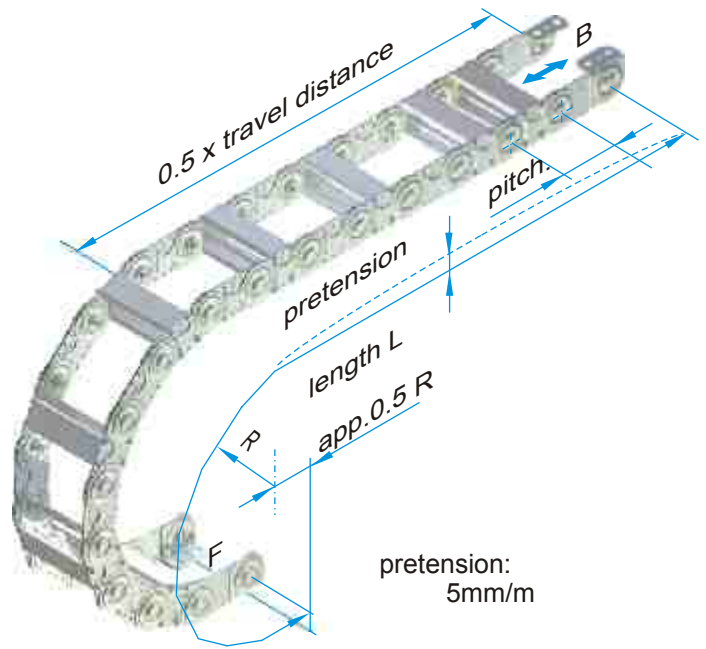

SLE	pitch	a	c	e	f	g	h	k	l ¹⁾	m	o	p	t	weight [kg/m]
120, 121, - , 128	50	20	35	10	6	7,5	7	1	9	7	10	20	4	2.3
220, 221, 225, 228	75	31	50	14	8	12	9	1,5	13	9	12	30	4	4.3 (5.8)
320, 321, 325, 328	100	49	75	16	11	17	11	2	18	12	12	50	4	7.9 (9.6)
520, 521, 525, 528	125	68	100	22	14	22	13	3	20	15	12	70	4	15.1 (16.9)
620, 621, 625, 628	175	118	150	22	14	26	13	3	20	15	24	115	8	19.3 (20.9)

the weight is given for the standard type with with a stay length of 100, values in brackets for closed version

1) stay length + 2l is the width of the chain with sliders

bending radius R [mm]

120, 121, - , 128			60	100	150		250								
220, 221, 225, 228				100	150	200	250	300							
320, 321, 325, 328 ¹⁾					150	200	250	300	400						
520, 521, 525, 528 ¹⁾						200	250	300	400	500					
620, 621, 625 ²⁾ 628 ¹⁾							250	300	400	500	600				

¹⁾ SLE 328 from R200, SLE 528 from R300, SLE 628 from R400 ²⁾ SLE 625 from R300

the stay lengths are offered in steps of 1 mm

stay length SLE plastic inserts Ø [mm]



120, 121, - , 128	40 ... 800														
220, 221, 225, 228	50 ... 900	10	15	20	25	30									
320, 321, 325, 328	60 ... 1000	10	15	20	25	30	35	40	45	50					
520, 521, 525, 528	70 ... 1200	10	15	20	25	30	35	40	45	50	55	60	65	70	
620, 621, 625, 628	100 ..1200														

order example:

travel distance 3 m, bending radius 200 mm,

cables: 1x15 mm, 8x8 mm, 3x12 mm, 2x22 mm,

normal arrangement

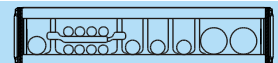

SLP 220 / 200 x 2325 / 200 /N/N¹⁾ / 5 PZ 1 PT55

type / radius x length / stay length / connectors / arrangement / stay distribution

1) 1. fixed connector / 2. moving connector

Normal connector in outer radius

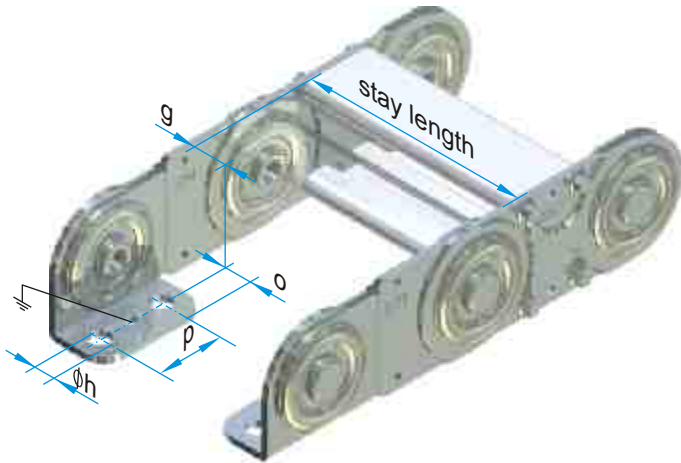

connector **E** in inner radius



SLE	connector screws
120	M 6
220	M 8
320	M10
520	M12
620	M12

connector **A**

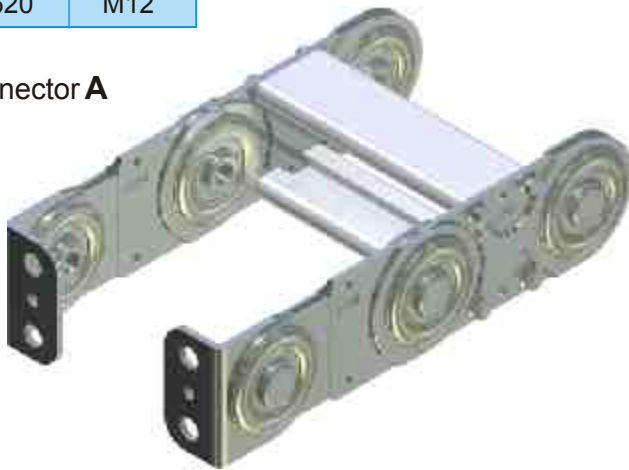

connector **B**

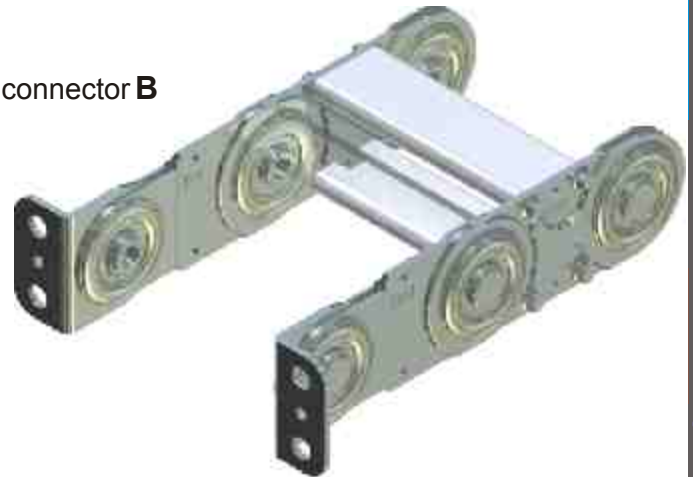

connector **C** in outer radius

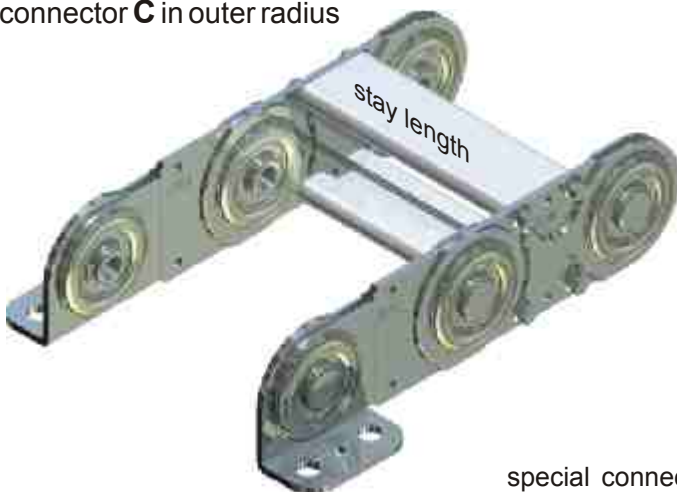

connector **D** in inner radius

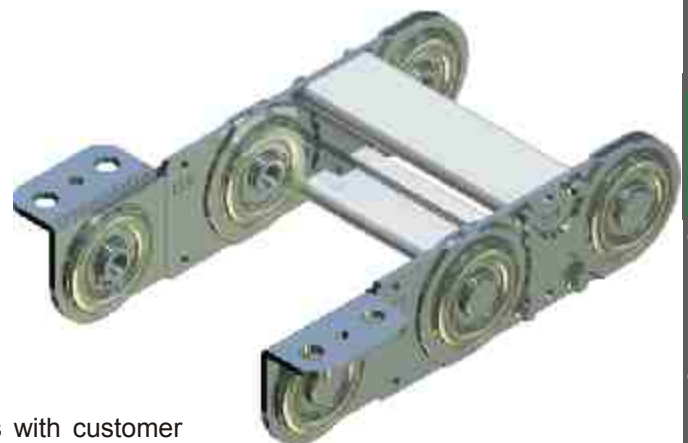

special connectors with customer dimensions are available

SLE TYPES

SLE 120, 220, 320, 520, 620

The standard type is built with stays in every second chain link. The steel link energy chains can be opened in the inner and in the outer bending radius.



order example

SLP 120	/	100	x	2050	/	100	/	D	/	E	/	h	/	2PZ
type		radius		length		stayw.		connect.		arran.		stay		dist.

SLE 121, 221, 321, 521, 621

These designs are made with stays in each link. This increases the lateral stability and improves the guiding particularly of smaller diameter lines.

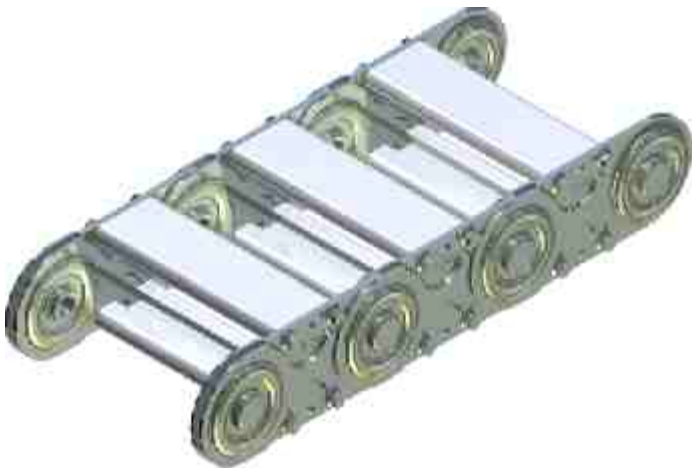

order example

SLP 321	/	100	x	3100	/	200	/	N	/	N	/	n	/	5PZ, 3PT
type		radius		length		stayw.		connect.		arran.		stay		dist.

SLE 225, 325, 525, 625

The closed types offer optimum protection of the lines against dust and cuts or other environmental influences. At higher temperatures the covers **Silver Star** provide excellent protection.

The closed types also may be built to replace the standard version stay.



order example

SLP 225	/	200	x	2550	/	150	/	N	/	N
type		radius		length		stayw.		connectors		

SLE 128, 228, 328, 528, 628

These types are suitable for long travel, the upper strand slides on the lower strand. For greater stability these energy chains are built with stays in each link. The energy chains are fitted with sliders, which have a very low coefficient of friction ($\mu = 0.2$ to 0.25).

After reaching the wear limit the slider can be renewed and the energy chain will continue.

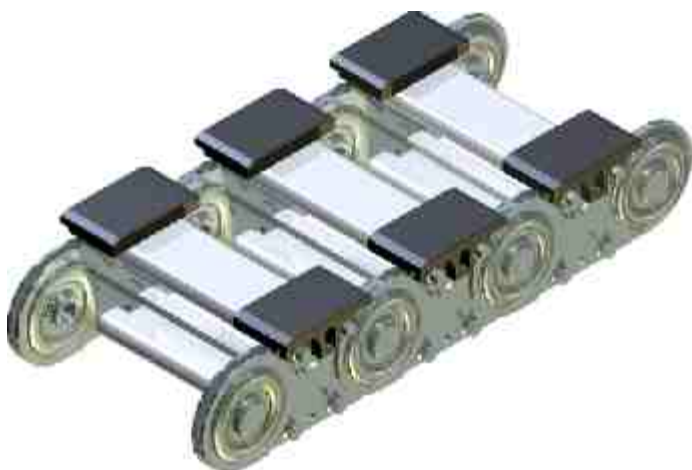

order example

SLP 328	/	200	x	45000	/	250	/	N	/	N	/	g	/	3PZ
type		radius		length		stayw.		connect.		arran.		stay		dist.

Compared to standard chains the SLE series is characterized by the fact that the sturdy aluminium profile can be steplessly adapted to the requirements. Stay lengths of up to 1500 mm can be provided. The subdivision of the interior satisfies every requirement and guarantees optimized cable protection, even at very high accelerations and travel speeds.

The **SLA** (SLE with aluminum T-profile or aluminium slot-profile) is a highly customized and robust energy chain, which is chosen primarily for larger dimensions. The stays are milled in accordance with the requirements of the user with individual hole patterns.

For extreme applications, the variants SLA, SLS and SLE should be preferred, since these offer optimize cable guiding. In the case of high speed and acceleration a multi-layer arrangement of the cable should be avoided.

The **SLE** (SLE with plastic inserts or plastic slot-profile) ensures at high speeds a perfect guide and almost excludes errors during installation of the lines. With this design the hole pattern of the stays can be adjusted accurately to the needs of the lines. Plastic inserts are available in a 5 mm grid. The plastic slot-profile can be ordered to suit special requirements.

For limited installation space, the **SLS** (SLE with foam slot-profile) are used. Again, the optimal guiding of the lines at high speeds and acceleration is ensured. Well-known automotive manufacturers have used this type for years with the best experiences. All lines lie in the neutral axis of the energy chain.

For space reasons, the **SLP** (SLE with plastic divider PZ and others) can be selected. This inexpensive design allows the guiding of large amounts of cable. The highly variable distribution possibility through small steps of (3mm) in height, plus the Telescopic divider (PT) allows maximum space for all needs, even when changes in cable diametres are required.

The **SLR** (SLE with a pipe or roll stays) is manufactured only upon request. The pipe stay allows special material combinations, such as the exclusion of aluminum or the use of stainless steel and brass. The roll bar has advantages particularly for heavy lines with high friction and wear in terms of durability of the cables and hoses: Relative movements on the energy chain are compensated by the rolling motion of the stays.

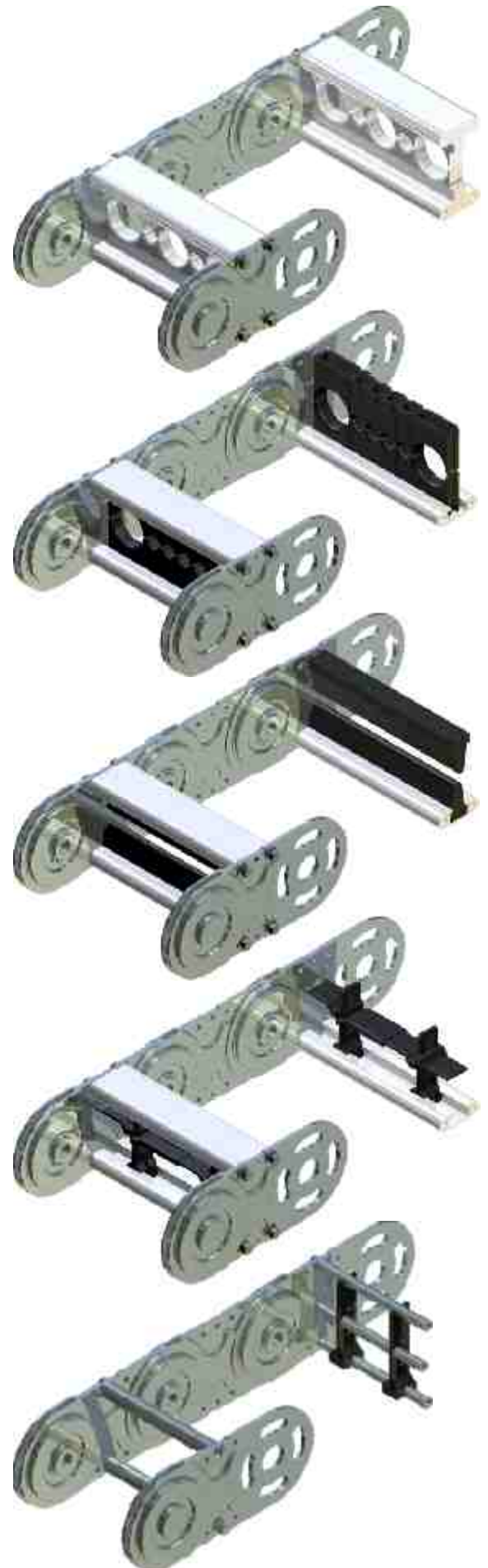

SLE SIZES



SLE 120

standard type		width:	52 ... 812
height:	35	inner width:	40 ... 800
inner height:	20		



SLE 220

standard type		width:	66 ... 916
height:	50	inner width:	50 ... 900
inner height:	31		



SLE 320

standard type		width:	80 ... 1020
height:	75	inner width:	60 ... 1000
inner height:	49		



SLE 520

standard type		width:	98 ... 1028
height:	100	inner width:	70 ... 1500
inner height:	68		



SLE 620

standard type		width:	128 ... 1228
height:	150	inner width:	100 ... 1500
inner height:	118		

item name

- 1 link
- 2 connector link single
- 3 connector link double
- 4 connector angle
- 5 flange bolt
- 6 radius bolt
- 7 cover plate
- 8 retaining ring
- 9 aluminum C-profile
- 10 serrated screw
- 11 plastic (vertical) divider
- 12 outer cover
- 13 spacer
- 14 inner cover
- 15 band holder
- 16 band (steel / stainless steel)
- 17 threaded bolt
- 18 lock washer
- 19 locknut
- 20 plastic inserts
- 21 foam
- 22 slider
- 23 aluminium-T-profile
- 24 pipe stay
- 25 flange rollers

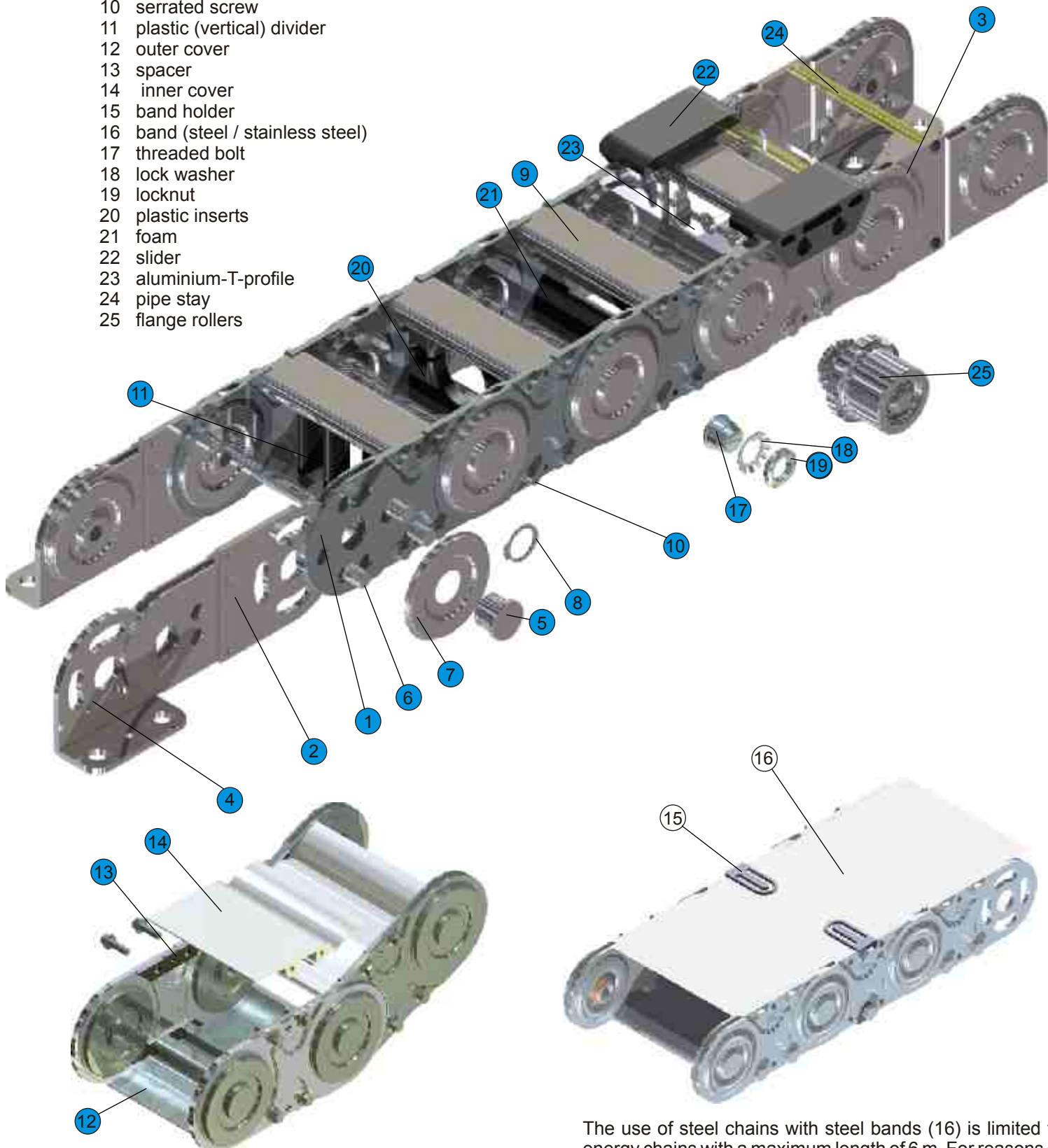

The use of steel chains with steel bands (16) is limited to energy chains with a maximum length of 6 m. For reasons of rigidity longer energy chains have to be built by using the **silver star** covers.

Packaging

ekd energy chains are supplied in secured device packaging. When removing the packaging and moving the energy chains or parts of them, ensure that the energy chains are free of torsion and tension to avoid mechanical damage.

Lengthening or shortening

If energy chains are delivered in pieces, proceed with the installation as follows:

Push the link together (1) and insert the flange bolts (5) with a shroud (7) in the chain outside. Then build the radius by inserting the radius bolts (6) (see chart for correct radius). Finally put on the inner shroud (7) and fit the retaining ring (8). Roll the energy chain to check that the radius is correct throughout its length.

Shortening in the reverse order:

Loosen the retaining rings (8), pull out the flange bolts (5), lifting the shroud (7), pull the radius bolts (6) and remove the links (1).

Energy chains with threaded bolts instead of the retaining rings (8), first unlock the locking plates (18) to solve the locknuts (19). Thereafter, the threaded bolts (17) and pins (6) can be removed and taken from the links (1).

Implement the connector angle

The connector angles (4) are orientated to the outer radius and to the chain center (normal end mounted). By loosening the retaining rings (8), drag the flange bolts (5), lift off the shroud (7) and pull the radius bolts (6) the connector angles (4) can be disassembled and placed in a different position.

Bending radius

Loosen the retaining rings (1) and lift off the shrouds (7). Implement the radius bolts (6) according to table (page 89). Then mounting the shrouds (7) and retaining Rings (1).

The detachable bolts position for the different radii can be found engraved on the double connector links (3).

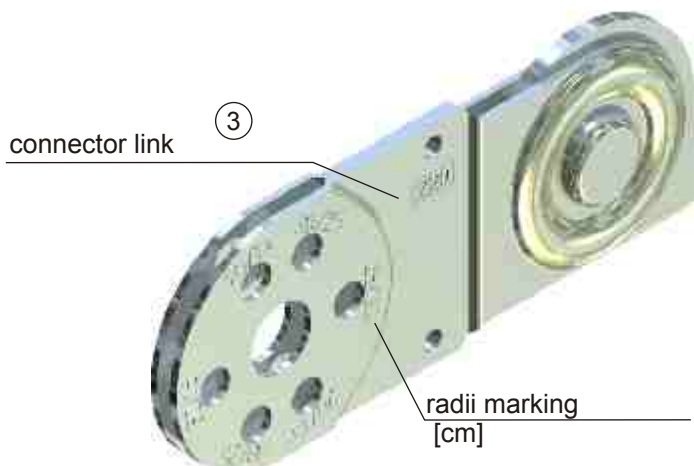
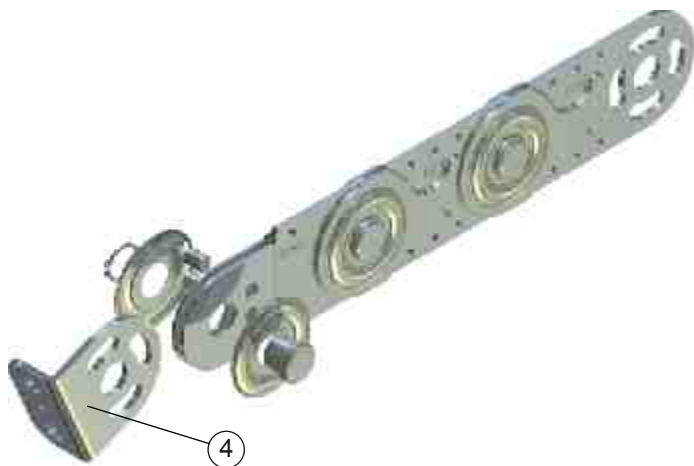
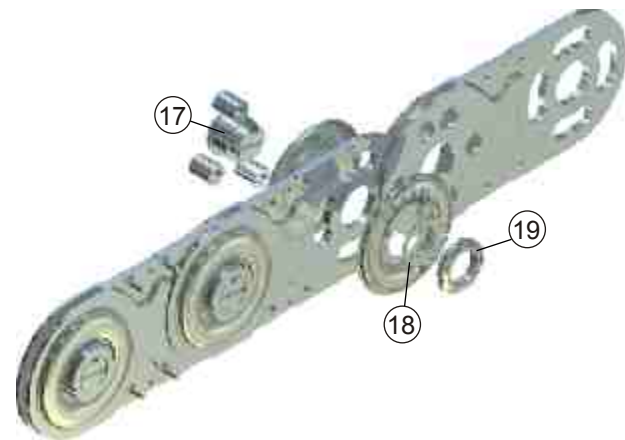
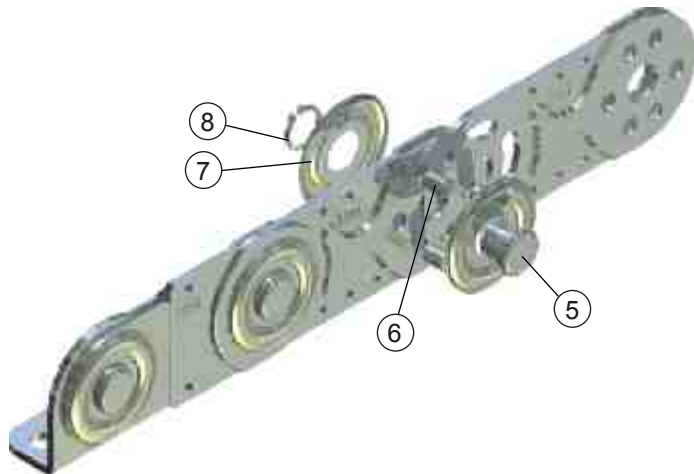

assembly of radius bolts

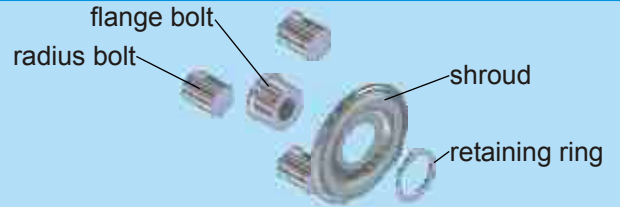

SLE **120** **220** **320** **520** **620**

radius	60	100	150	200	250	<p>(marking in the outer radius)</p> <p>the minimum radius is built with only 2 bolts</p>
radius	100	150	200	250	300	<p>(marking in the outer radius)</p>
radius	150	200	250	300	400	<p>(marking in the outer radius)</p>
radius	250	250	300	400	500	<p>(marking in the inner radius)</p>
radius	-	300	400	500	600	<p>(marking in the inner radius)</p>

Stay removal

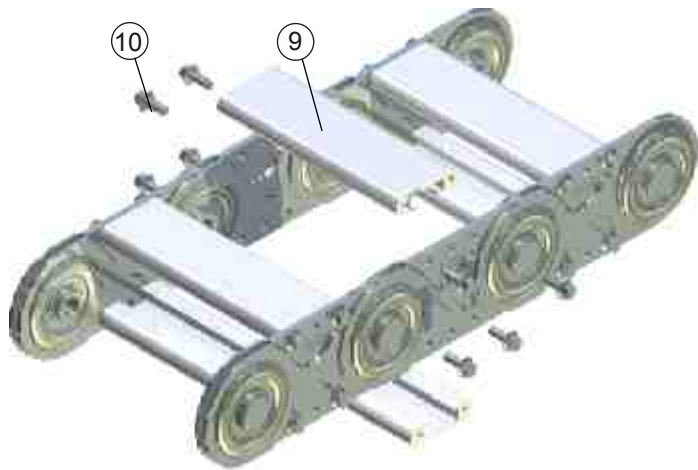

The stays (9) are fastened with serrated screws (10) to the links (1). They can be removed by unscrewing the four screws (10).

Stay lengths up to 600 mm are available with quick assembly.

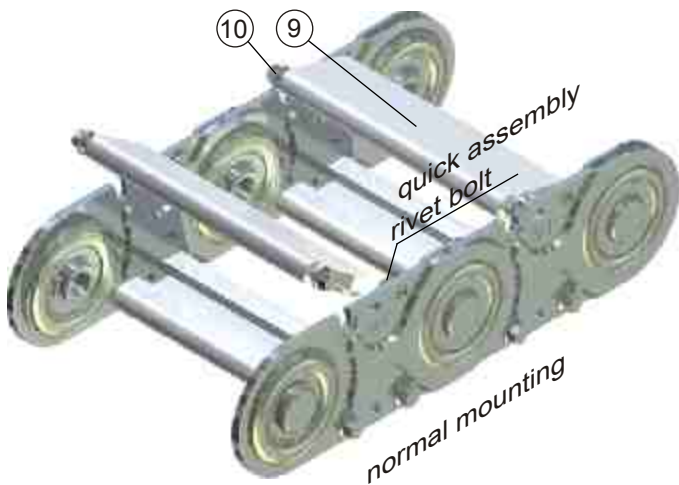

Quick assembly

In quick assembly only two screws must be tightened or loosed. The stays (9) are moved with the groove on the rivet and the serrated screw (10) snapped in the recess and tightened.



Cover Silver Star

The covers of the closed version can be removed like the stays by loosening the four serrated screws (10). The spacers (13) remain on the links.

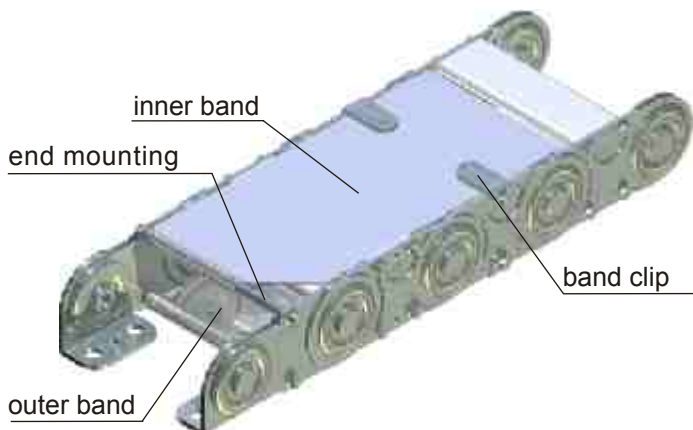

Stainless steel bands

To protect the lines against external damage and pollution the chains can be equipped with steel or stainless steel bands in the inner and outer radius. The edges of the steel bands are circular smoothed to avoid injury. Stainless steel and steel bands are fastened with band holders screwed on sides and with screwed connections on each end of the chain.

Final assembly

The installation height should not fall below the level $H = (50 \text{ plus two times bend radius plus link height})$.
The pretension of cable carrier is taken into account with the additional space of 50 mm.

First fasten fixed connection (F) and then mount the movable connection using the specified bolt size (see SLE connectors).
Compliance with the maximum free carrying length is of vital importance for the life time of the energy chain, both during the installation as well as when operational. Over travel of the energy chain can lead to damage and premature wear.

If the energy chain is provided with support elements, the assembly of these must take place before the installation of the chain in order to avoid even a short-term stress point.

An energy chain may never exceed the free carrying length without support rollers.

The height of the moved connector must be adjusted so that the connector link is moving with a maximum of 5 mm distance from the base of the supporting roller.

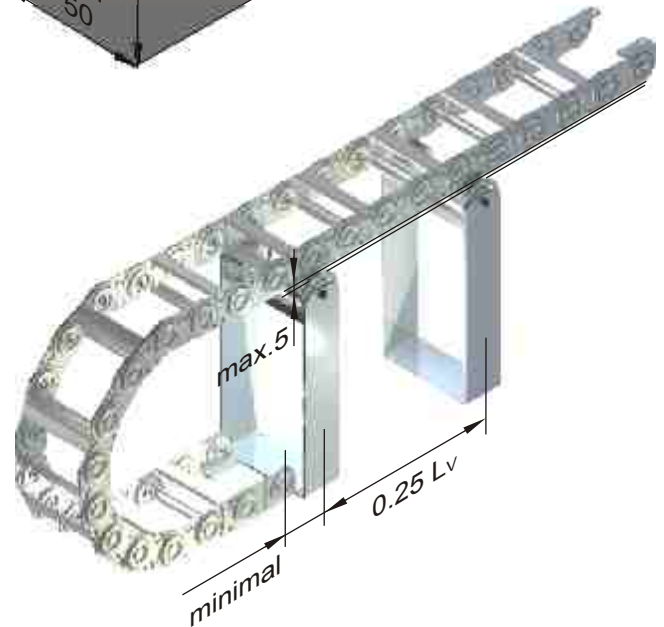
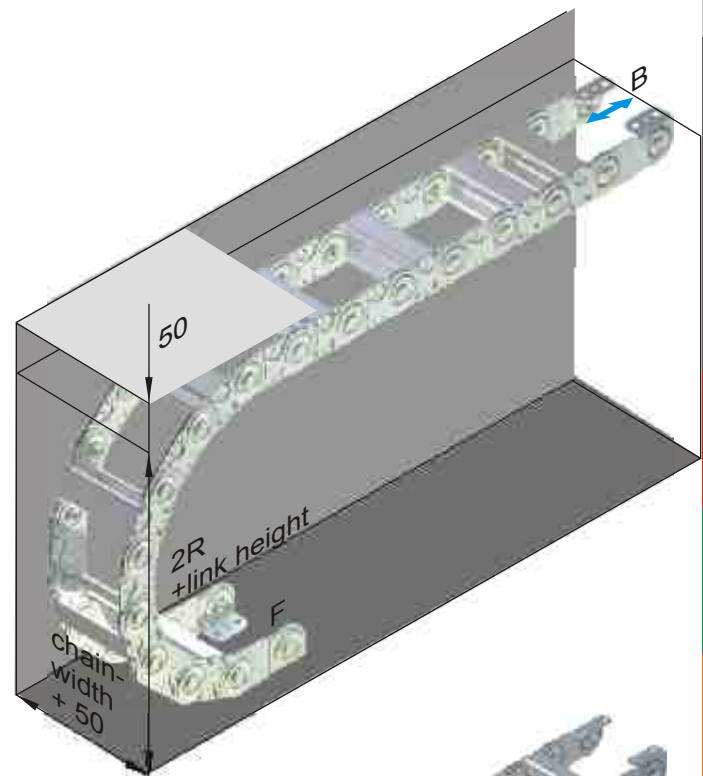

Maintenance of the energy chain

PLE energy chains are maintenance free. Like every mechanical system this will depend on the ambient conditions so wear will occur which must be observed.

In case of the energy chain has to be exchanged.

For long travels or in a circular motion, the energy chains are often equipped with sliding elements. These allow sliding of the upper part of the chain on a suitable surface (eg, slider-slider, slider-steel, glide bar).

The sliders wear depends on the application. The slider surfaces should be checked at regular intervals. With a thickness of 1-2 mm sliders have to be replaced.

SLE parts 87

1



SLE link

4

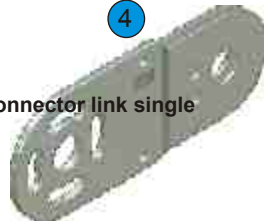

connector link single

2



connector link double

3



connector angle

R 60, 100, 150, 250

	galv.	carbur.	Stainl.steel		galv.	carbur.	Stainl.steel		galv.	carbur.	Stainl.steel		galv.	carbur.	stainl.steel
120	0110	-	1738		0104	-	-		0105	-	-		0064	-	1732
121	0110	-	1738		0104	-	-		0105	-	-		0064	-	1732
128	0110	-	1738		0104	-	-		0105	-	-		0064	-	1732

R 100, 150, 200, 250, 300

	galv.	carbur.	Stainl.steel		galv.	carbur.	Stainl.steel		galv.	carbur.	Stainl.steel		galv.	carbur.	stainl.steel
220	0117	0821	1739		0115								0114		
221	0117	0821	1739		0115								0114		
225	0117	0821	1739		0115								0114		
228	0117	0821	1739		0115								0114		

R 150, 200, 250, 300, 400

	galv.	carbur.	Stainl.steel		galv.	carbur.	Stainl.steel		galv.	carbur.	Stainl.steel		galv.	carbur.	stainl.steel
320	0147	1725	1726		0145		1720		0146		1721		0144		1719
321	0147	1725	1726		0145		1720		0146		1721		0144		1719
325	0147	1725	1726		0145		1720		0146		1721		0144		1719
328	0147	1725	1726		0145		1720		0146		1721		0144		1719

R 200, 250, 300, 400, 500

	galv.	carbur.	Stainl.steel		galv.	carbur.	Stainl.steel		galv.	carbur.	Stainl.steel		galv.	carbur.	stainl.steel
520 / 510	0703 / 0175		1727 1730		0173		1689		0174		1690		0172		1536
521 / 511	0703 / 0175		1727 1730		0173		1689		0174		1690		0172		1536
525 / 515	0703 / 0175		1727 1730		0173		1689		0174		1690		0172		1536
528 / 518	0703 / 0175		1727 1730		0173		1689		0174		1690		0172		1536

R 250, 300, 400, 500, 600

	galv.	carbur.	Stainl.steel		galv.	carbur.	Stainl.steel		galv.	carbur.	Stainl.steel		galv.	carbur.	Stainl.steel
620	0878		-		0877				0876				0844		
621	0878		-		0877				0876				0844		
625	0878		-		0877				0876				0844		
628	0878		-		0877				0876				0844		

SLE PART NUMBERS

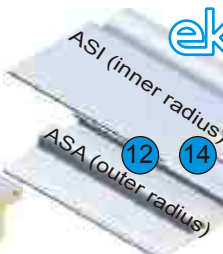

SLE parts 87

SLE shroud retaining ring radius bolt flange bolt C-profile T-profile ASA / ASI distance filler serrated screw

St VA St CuSn St VA links rechts

120	0107	-	0109	-	0106	-	0108	-	0692	-	-	-	-	-	0127 (M4x12)
121	0107	-	0109	-	0106	-	0108	-	0692	-	-	-	-	-	0127
128	0107	-	0109	-	0106	-	0108	-	0692	-	-	-	-	-	0127

220	0119	0137	0118	0136	0120	0121	0122	0134	0124	0141	-	-	-	-	0127 (M4x12)
221	0119	0137	0118	0136	0120	0121	0122	0134	0124	0141	-	-	-	-	0127
225	0119	0137	0118	0136	0120	0121	0122	0134	-	-	1065	1066	1670	1404	0127
228	0119	0137	0118	0136	0120	0121	0122	0134	0124	0141	-	-	-	-	0127

320	0149	0166	0148	0167	0150	0151	0152	0165	0154	0171	-	-	-	-	0157 (M5x14)
321	0149	0166	0148	0167	0150	0151	0152	0165	0154	0171	-	-	-	-	0157
325	0149	0166	0148	0167	0150	0151	0152	0165	-	-	0847	0846	1293	1671	0157
328	0149	0166	0148	0167	0150	0151	0152	0165	0154	0171	-	-	-	-	0157

520	0177	0193	0176	0192	0178	0179	0448	1 529	0182	0194	-	-	-	-	0185 (M6x18)
521	0177	0193	0176	0192	0178	0179	0448	1529	0182	0194	-	-	-	-	0185
525	0177	0193	0176	0192	0178	0179	0448	1529	-	-	0849	0848	1405	1673	0185
528	0177	0193	0176	0192	0178	0179	0448	1529	0182	0194	-	-	-	-	0185



620	0872		0176	0192	-	0874	0180	-	0182	0851	-	-	-	-	0185 (M6x18)
621	0872		0176	0192	-	0874	0180	-	0182	0851	-	-	-	-	0185
625	0872		0176	0192	-	0874	0180	-	-	-	0957	0956	1406	1674	0185
628	0872		0176	0192	-	0874	0180	-	0182	0851	-	-	-	-	0185

SLE parts 87

11



PZ



PTF PT 55 PT 75



LL 25



LL 50



LS

SLE

120	0691		0112			-	-	-		-	-	1665
121	0691		0112			-	-	-		-	-	1665
128	0691		0112			-	-	-		-	-	1665
220	0778	1519	0779	1658		0879	0879	0880		1663	1664	1665
221	0778	1519	0779	1658		0879	0879	0880		1663	1664	1665
221	0778	1519	0779	1658		0879	0879	0880		1663	1664	1665
225	0778	1519	0779	1658		0879	0879	0880		1663	1664	1665
228	0778	1519	0779	1658		0879	0879	0880		1663	1664	1665
320	0163	1678	1659	1660		0879	0879	0880		1663	1664	1665
321	0163	1678	1659	1660		0879	0879	0880		1663	1664	1665
325	0163	1678	1659	1660		0879	0879	0880		1663	1664	1665
328	0163	1678	1659	1660		0879	0879	0880		1663	1664	1665
520	0719	1679	1661	1662	1680	0879	0879	0880		1663	1664	1665
521	0719	1679	1661	1662	1680	0879	0879	0880		1663	1664	1665
525	0719	1679	1661	1662	1680	0879	0879	0880		1663	1664	1665
528	0719	1679	1661	1662	1680	0879	0879	0880		1663	1664	1665
620	1257	1110	-	-		-	-	-		-	-	-
621	1257	1110	-	-		-	-	-		-	-	-
625	1257	1110	-	-		-	-	-		-	-	-
628	1257	1110	-	-		-	-	-		-	-	-

SLE PART NUMBERS

plastic inserts

diameter in mm

SLE 10 15 20 25 30 35 40 45 50 55 60 65 70

120	-	-	-	-	-	-	-	-	-	-	-	-	-
121	-	-	-	-	-	-	-	-	-	-	-	-	-
128	-	-	-	-	-	-	-	-	-	-	-	-	-



220	649	650	651	652	653	-	-	-	-	-	-	-	-
221	649	650	651	652	653	-	-	-	-	-	-	-	-
225	649	650	651	652	653	-	-	-	-	-	-	-	-
228	649	650	651	652	653	-	-	-	-	-	-	-	-









320	654	665	656	657	658	659	660	661	662	-	-	-	-
321	654	665	656	657	658	659	660	661	662	-	-	-	-
325	654	665	656	657	658	659	660	661	662	-	-	-	-
328	654	665	656	657	658	659	660	661	662	-	-	-	-



520	1628	663	664	665	666	667	668	669	670	671	672	714	715
521	1628	663	664	665	666	667	668	669	670	671	672	714	715
525	1628	663	664	665	666	667	668	669	670	671	672	714	715
528	1628	663	664	665	666	667	668	669	670	671	672	714	715

620	-	-	-	-	-	-	-	-	-	-	-	-	-
621	-	-	-	-	-	-	-	-	-	-	-	-	-
625	-	-	-	-	-	-	-	-	-	-	-	-	-
628	-	-	-	-	-	-	-	-	-	-	-	-	-

SLE	plastic- insert profile	aluminium insert profile	foam	sliders	flange rollers (complete)
120	-	-	-		
121	-	-	-		
128	-	-	-	1443  H=3,5	
220	0 827	1649	0730		1069 
221	0 827	1649	0730		1069
225	0 827	1649	0730		1069
228	0 827	1649	0730	1444  H=7,5	-
320	1646	1650	0731		1070
321	1646	1650	0731		1070
325	1646	1650	0731		1070
328	1646	1650	0731	1445  1448  H=9,5	-
520	1647	1651	0732		1071
521	1647	1651	0732		1071
525	1647	1651	0732		1071
528	1647	1651	0732	1446  H=9	-
620	1648	1652	-		1071
621	1648	1652	-		1071
625	1648	1652	-		1071
628	1648	1652	-	1447  H=9	-

SLE PART NUMBERS



SLE damping element screw nut

glide disc
St vz VA

D45

120				0694		0693 0969 (compl.)		
121				0694		0693 0969 (compl.)		
128				0694		0693 0969 (compl.)		

D55

D70

220	0819	0826	0825	0123	0138	0128 0963 (compl.)	0129 0964 (compl.)	
221	0819	0826	0825	0123	0138	0128 0963 (compl.)	0129 0964 (compl.)	
225	0819	0826	0825	0123	0138	0128 0963 (compl.)	0129 0964 (compl.)	
228	0819	0826	0825	0123	0138	0128 0963 (compl.)	0129 0964 (compl.)	

D80

D95

320	0819	0826	0825	0153	1718	0158 0965 (compl.)	0159 0966 (compl.)	
321	0819	0826	0825	0153	1718	0158 0965 (compl.)	0159 0966 (compl.)	
325	0819	0826	0825	0153	1718	0158 0965 (compl.)	0159 0966 (compl.)	
328	0819	0826	0825	0153	1718	0158 0965 (compl.)	0159 0966 (compl.)	

D105

D120

520	0819			0181		0186 0967 (compl.)	0187 0968 1575 (br.)	
521	0819			0181		0186 0967 (compl.)	0187 0968 1575 (br.)	
525	0819			0181		0186 0967 (compl.)	0187 0968 1575 (br.)	
528	0819			0181		0186 0967 (compl.)	0187 0968 1575 (br.)	

D155

D170

620							1538	1539
621							1538	1539
625							1538	1539
628							1538	1539

Support brackets and support rollers

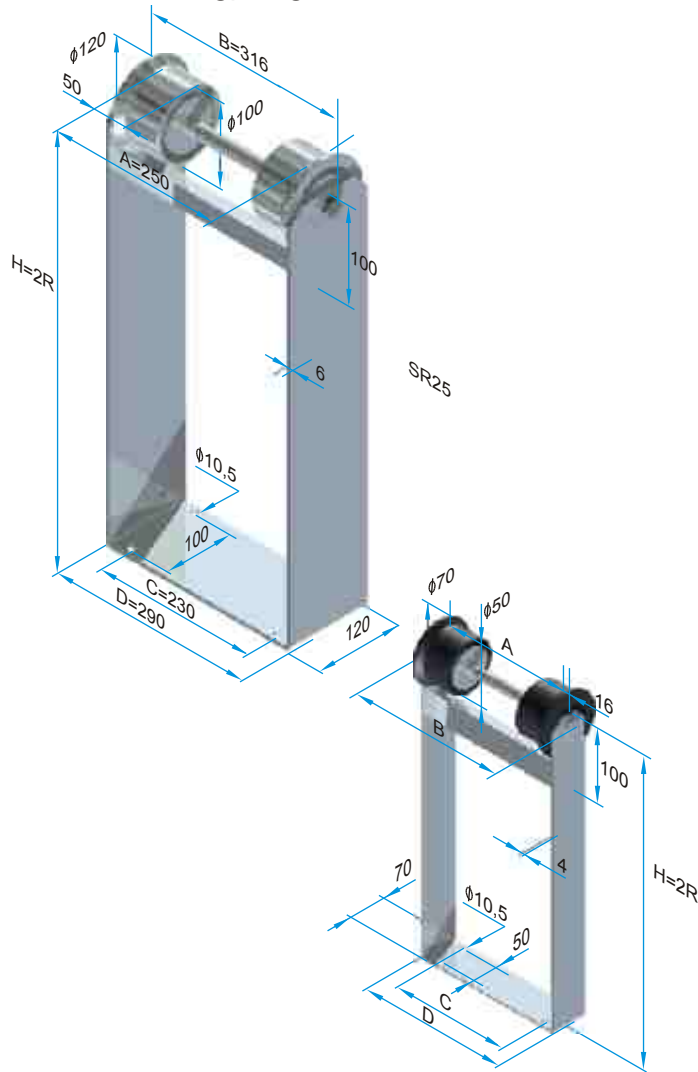

Support rollers are used when half of the travel exceeds the free carrying length ($L_v > 2LF$).

Support rollers allow four times extension of travel distance (see design guidelines).

The order of support rollers SR with support brackets for SLE ($\varnothing 100$ for all sizes) contains the following information:

SR width of support [cm] / $\varnothing 100$ x height of bracket

The width of the support (A) depends on the width of the energy chain (see table).

The height (H) of the support depends on the bending radius of the used energy chain: $H = 2R + \text{max. } 5\text{mm}$

For example, bend radius 200 mm, stay length 215 mm:

SR 25 / $\varnothing 100$ x 400

The steel support rollers are delivered with robust high-quality support frames.

The height of the moved connector must be adjusted with a maximum 5mm distance from the base of the supporting roll.

As an alternative to steel rollers SR, plastic support rollers PR for plastic chains are available.

PR	A	B	C	D
6	60	126	40	100
10	100	166	80	140
15	150	216	130	190
20	200	266	180	240
25	250	316	230	290
30	300	366	280	340
35	350	416	330	390
40	400	466	380	440
45	450	516	430	490
50	500	566	480	540
55	550	616	530	590
60	600	666	580	640
65	650	716	630	690
70	700	766	680	740
75	750	816	730	790
80	800	866	780	840
85	850	916	830	890
90	900	966	880	940
95	950	1016	930	990
100	1000	1066	980	1040

SR	A	B	C	D
	intermediate dimensions on request			
10	100	166	80	140
15	150	216	130	190
20	200	266	180	240
25	250	316	230	290
30	300	366	280	340
35	350	416	330	390
40	400	466	380	440
45	450	516	430	490
50	500	566	480	540
55	550	616	530	590
60	600	666	580	640
65	650	716	630	690
70	700	766	680	740
75	750	816	730	790

Dimension of PR and SR are depending on the chain width:

$$A = \text{stay length} + 2f + 20$$

Flange rollers

The flange rollers are used for very long chains in combination with a support railing with supporting rollers and support frames (see design guidelines).

Guide rollers for steel chains

Guide rollers are used for steel chains in arrangement u (moving end downside, see arrangements). In this case provide a trough or a corresponding support rail.

	v
SL 220	44
SL 320	46
SL 520	50
SL 620	50

Gliding discs for steel chains

For the SLE in arrangement w (lying horizontally on the side) for the longest travel distance or in arrangement k (circular) gliding discs are used. The gliding discs are made of high quality, highly abrasion-resistant materials. In both arrangements a guide is necessary.

Shelf troughs for steel chains

Shelf troughs consist of two standard angular channels that are welded together from 3m lengths. Shelf troughs will be used if a smooth and precise guidance of steel chains is necessary.

Important for the assembly: Weld angular channels smooth and without any offset and clean the weld seams. In the entire shelf area no projections or obstructions may be present (eg, screw heads, nuts,).

Support carriage for steel chains

Steel chains with support carriage are used for long travel distances and very high additional weights in a counter-chain arrangement. With side-mounted guide rollers the energy chains are supported on the support carriage.

Technical Features: No push - just pull-tension, large travel distances, extreme additional loads, smooth running, long life.

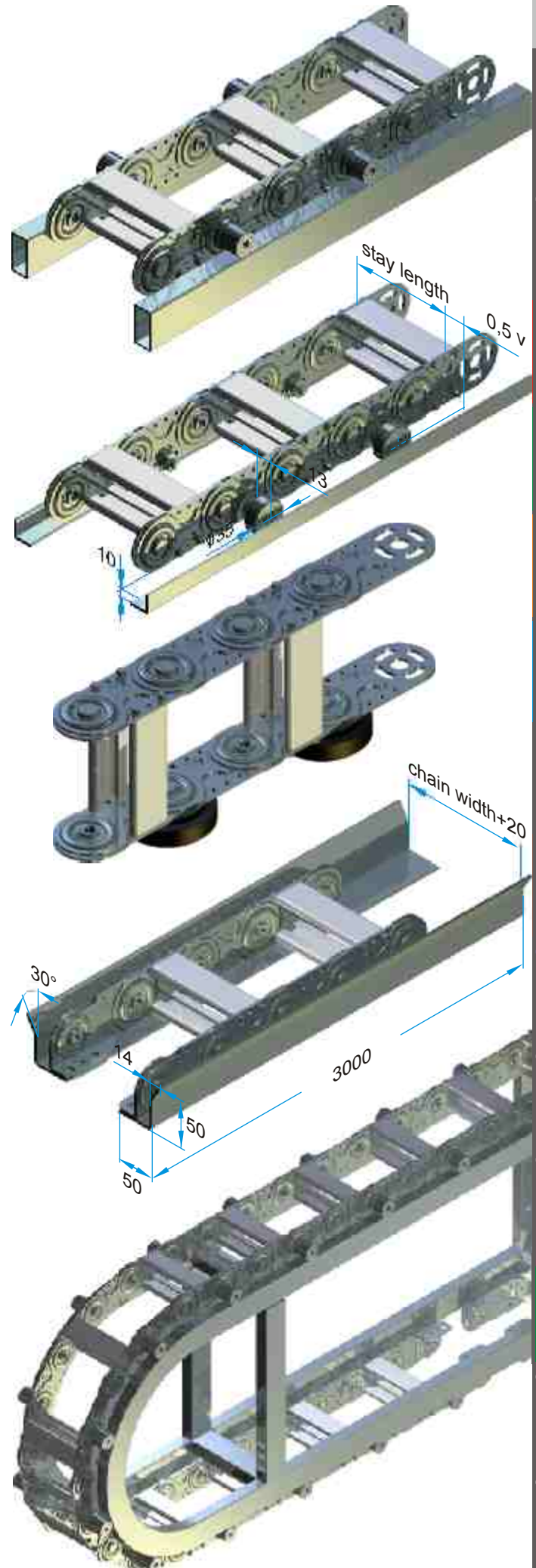

GKA

- GKA dimensions 102
- GKA connectors 103
- GKA types 103
- GKA sizes 104
- GKA parts 105

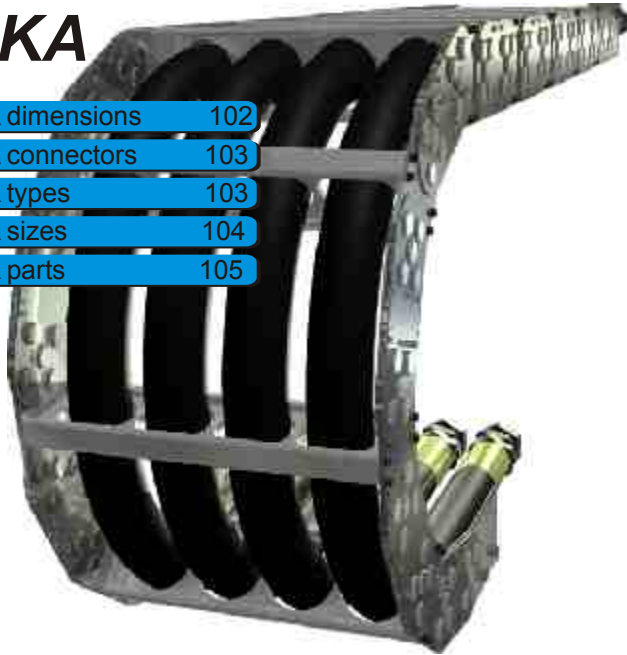

GKA characteristics

The GKA is characterized by the highest stability compared to standard chains, with almost unlimited dimensions and the choice of material.

The interior is custom formed and thus guarantees an optimal cable guiding.

Stay lengths up to 1200 mm are possible.

The bending radius can be created according to customer specifications if required.

Dimensions

bend radius:	200	to	...	mm
inner height:	118	to	468	mm
inner width:	100	to	1500	mm
energy chain weight:	25	to	85	kg / m

Travel

The maximum travel distance is determined by the arrangement and the additional weight (line weight). At normal arrangement maximum travel is double the chain length minus the arc of the chain radius. Support rollers or similar constructive steps can increase this value.

Travel speed

The standard and the stainless steel type are limited at 1 m / s. Exceeding this and high dynamic loads caused by eg vibrations need the use of carburated material.

Acceleration

The acceleration in principle is not limited. However limits may exist if very long chains and line weights cause extreme tensile forces.

Service temperature

The operating temperature is -20 ° C up to 600 ° C (stainless steel -40 ° C up to 600 ° C).

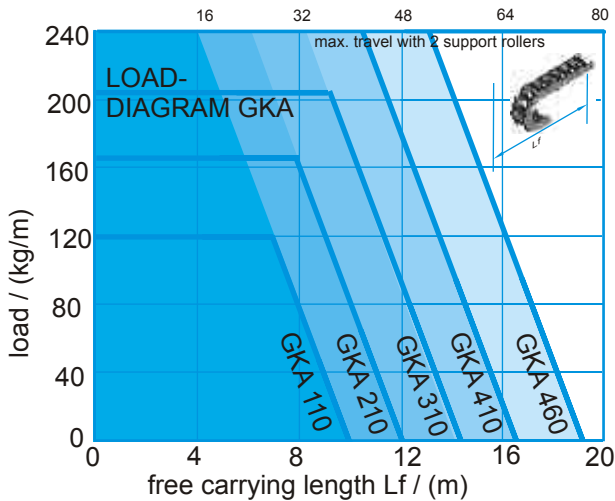

application range

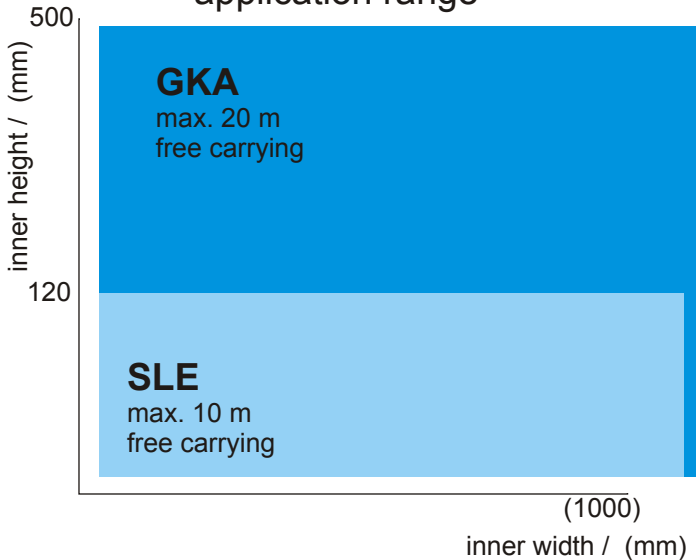

GKA with aluminum profile

A highly customized and robust design that is used mainly in larger steel chains. The stays are created according to the specifications of the user:



steel plant: GKA 161

GKR with rods

Made of stainless steel this energy chain is generally offered for off-shore, since aluminum is not suitable for these applications. The chains can be separated into different sections by additional stainless steel dividers:



water power plant: GKR 260

GKP with plastic dividers

These stays can be especially used for heavy mechanical engineering. The advantages in comparison to the GKA (aluminum profile) are in the price, the weight and space savings.

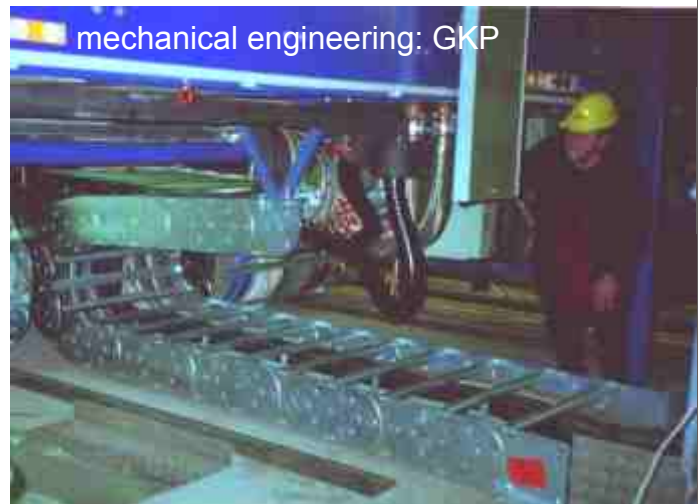

mechanical engineering: GKP

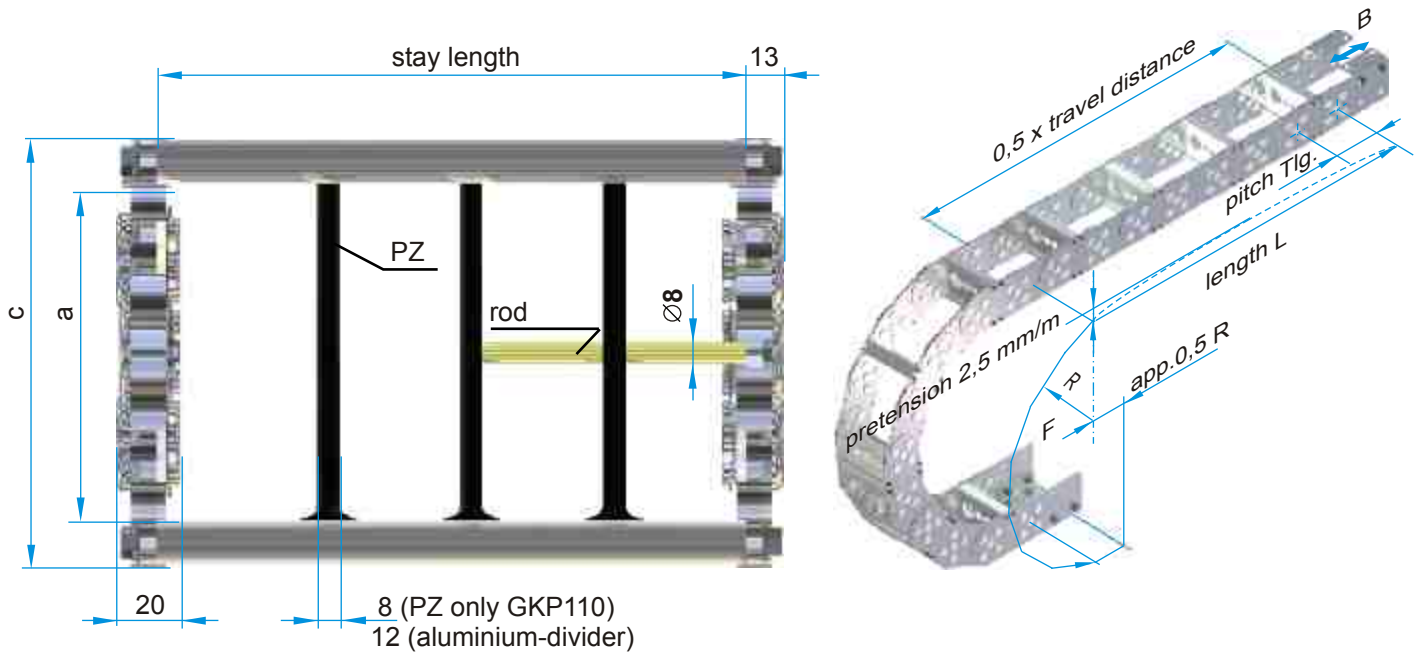

GKA	bending radius	Tlg. pitch	a	c	o	p	weight ¹⁾ kg/m
110	as specified (>200)	175	118	150	230	110	25
160	as specified (>250)	225	168	200	300	160	30
210	as specified (>300)	275	218	250	370	210	40
260	as specified (>400)	325	268	300	430	260	45
310	as specified (>450)	375	318	350	500	310	55
360	as specified (>550)	425	368	400	560	360	65
410	as specified (>600)	475	418	450	620	410	75
460	as specified (>700)	525	468	500	680	460	85

¹⁾weight for stay length 500

The bending radius is freely chosen after consultation. It is advantageous to adjust the bending radius of the chain to achieve a minimal polygon effect.

Stay lengths are available in steps of 1 mm.

The usable interior width is stay length minus 14 mm

Stay types and connectors may vary from those representations. Energy chains GKA are custom made in consultation with the client, usually from drawing. Item numbers are not given for this reason.

For energy chains type GKA choose the order length as an uneven multiple of the pitch.

order example: max. travel distance 20,9 m, bend radius 800 mm, normal constellation

GKA 460 / 800	x	14175	/ 1000	/ N/N	acc. drawing
type / radius	x	length	/staylength	/ connectors	

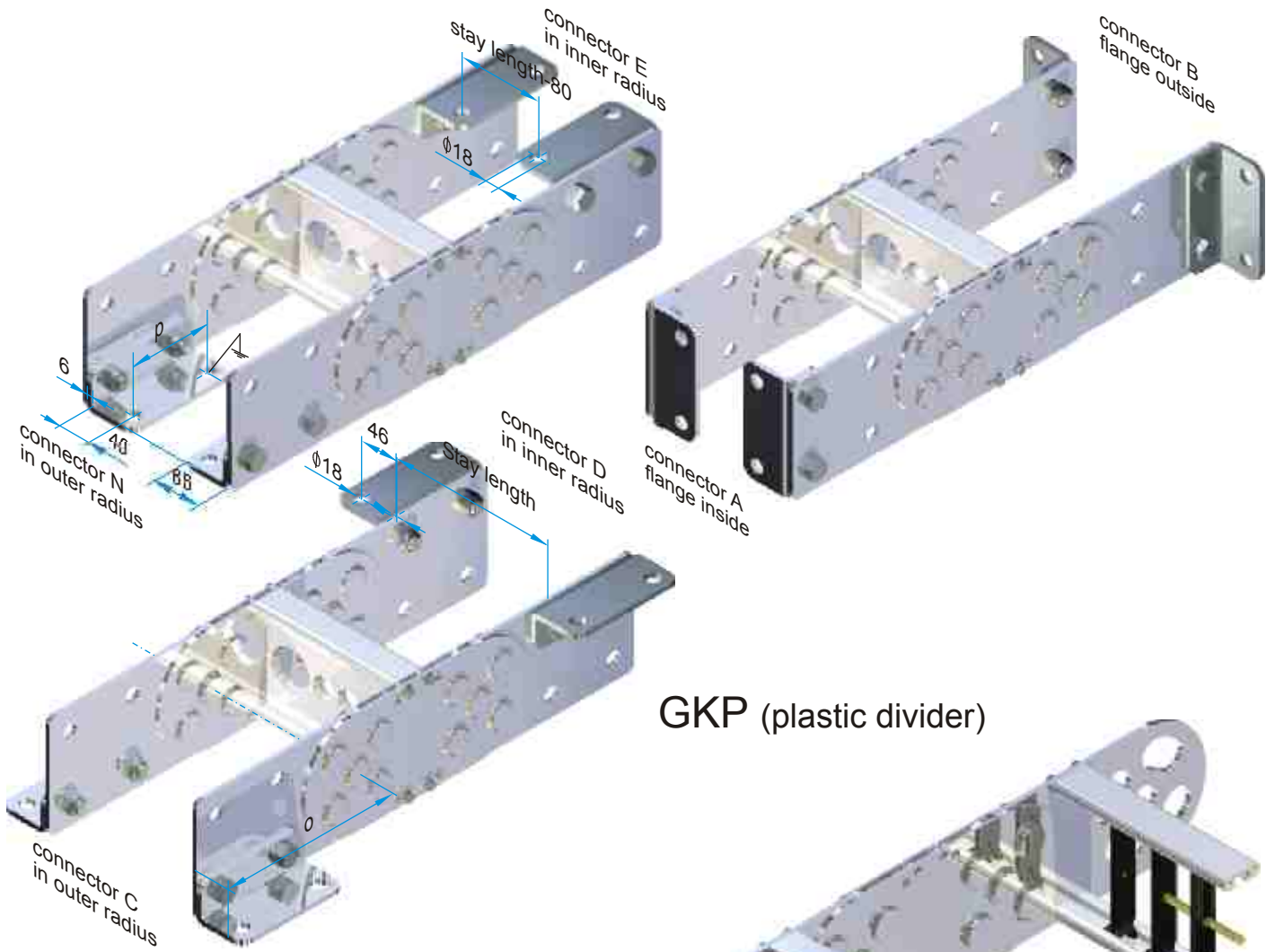

GKP (plastic divider)

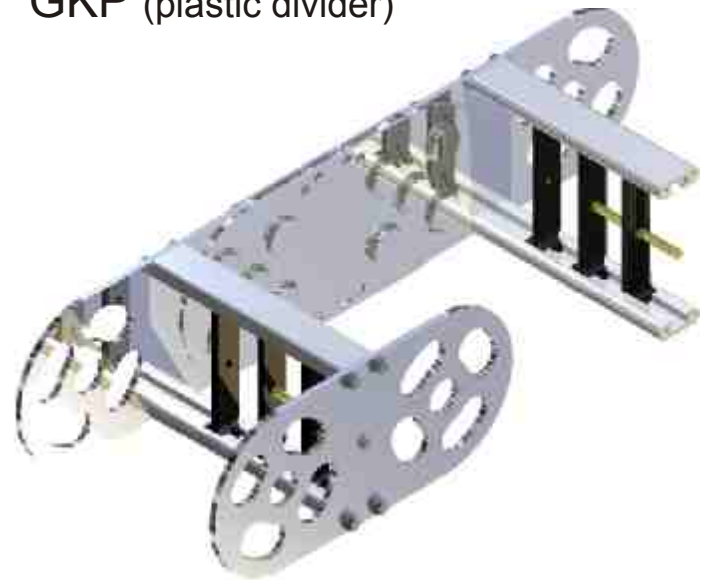

GKA (aluminium stays)



GKR (rods)

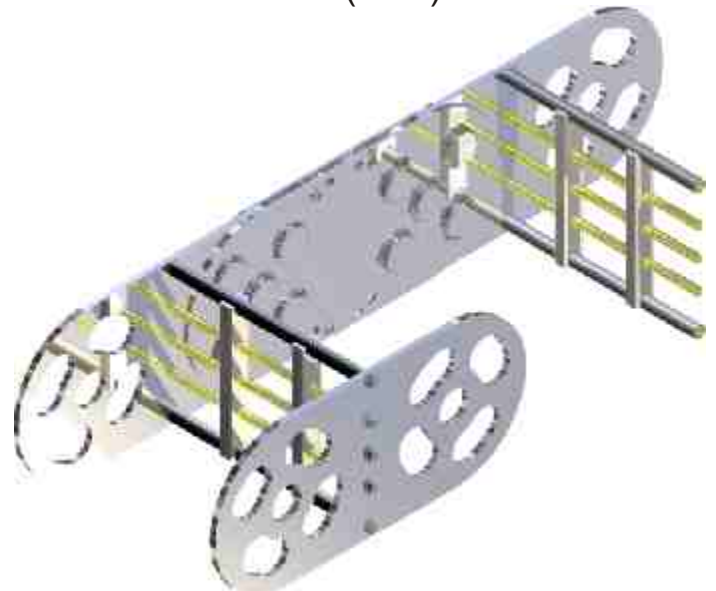

GKA sizes

GKA 110

height 150 ,width and bending radius as specified



GKA 160

height 200 ,width and bending radius as specified

GKA 210

height 250 ,width and bending radius as specified

GKA 260

height 300 ,width and bending radius as specified

GKA 310

height 350 ,width and bending radius as specified

GKA 360

height 400 , width and bending radius as specified

GKA 410

height 450 ,width and bending radius as specified

GKA 460

height 500 ,width and bending radius as specified

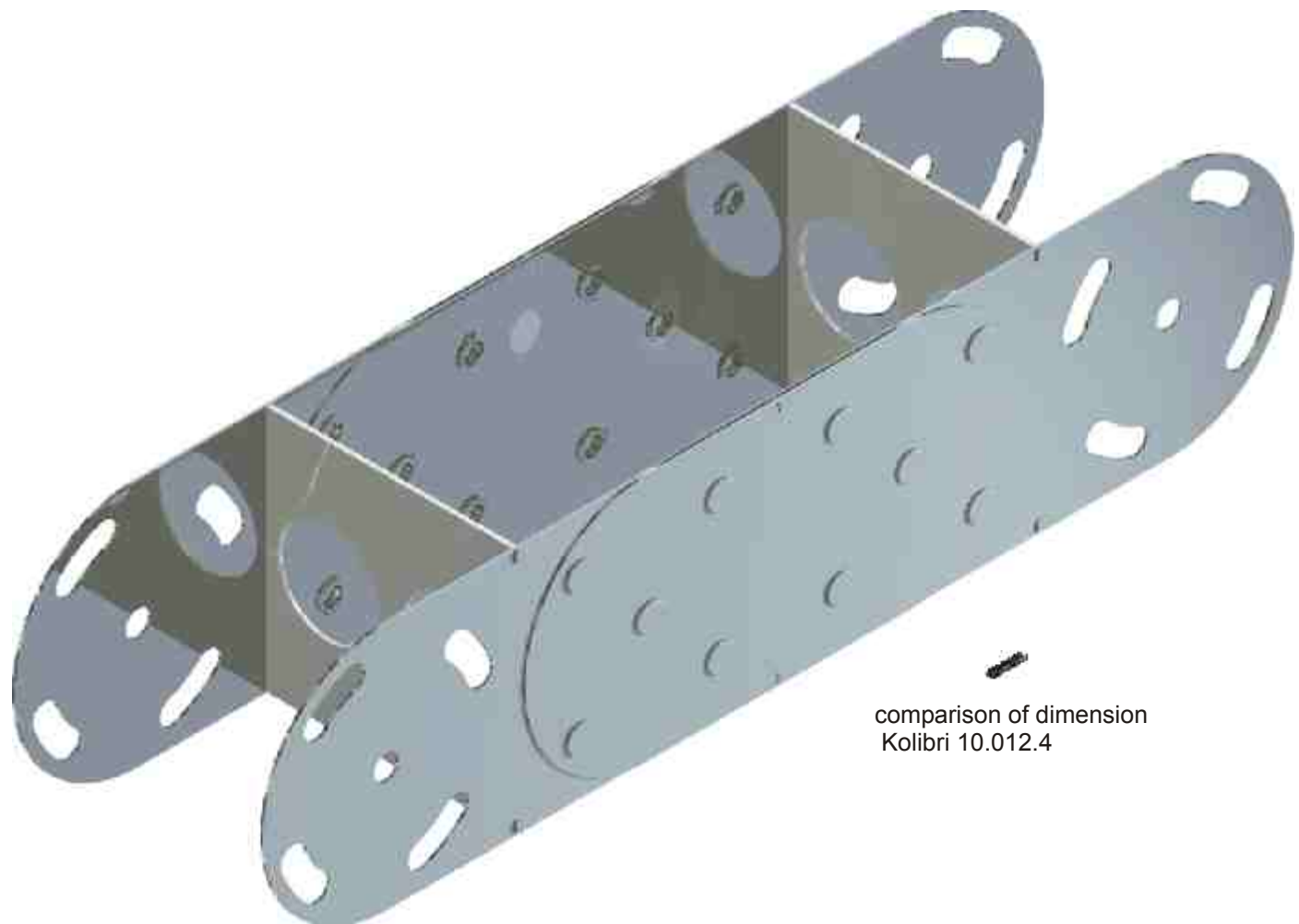

comparison of dimension
Kolibri 10.012.4

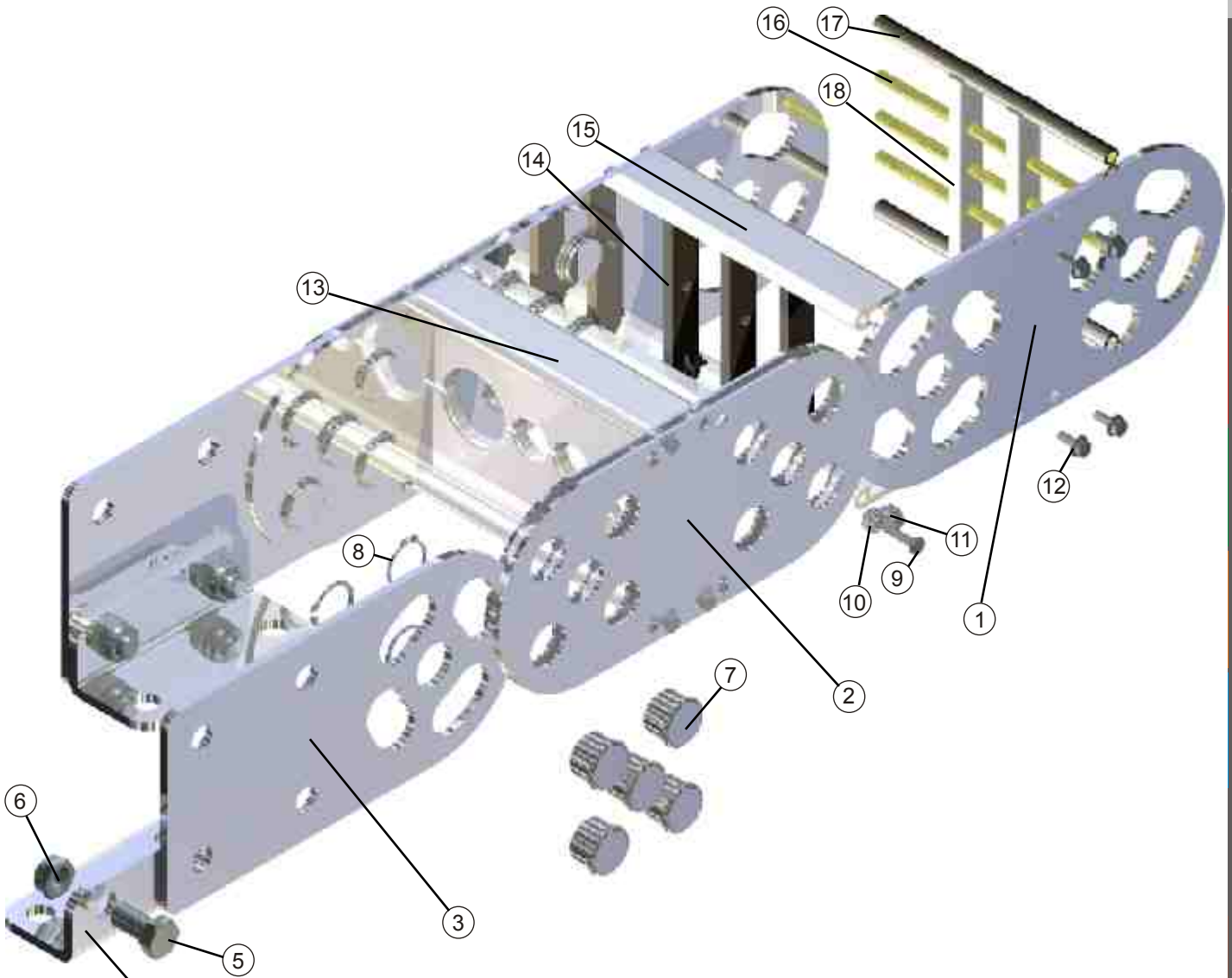

item	name
1	link with slot
2	link with drilling
3	connector links
4	connector angle
5	screw M16 x 25
6	nut M16 (self locking)
7	flange bolt
8	retaining ring A30
9	screw M6 x 25
10	distance filler
11	rivet bushing
12	serrated screw M6 x16
13	aluminum T-profile GKA
14	plastic divider (PZ)
15	aluminum C-profile GKA
16	rod
17	roller stay
18	aluminum divider

SFK

SFK dimensions 106

SFK connectors 107

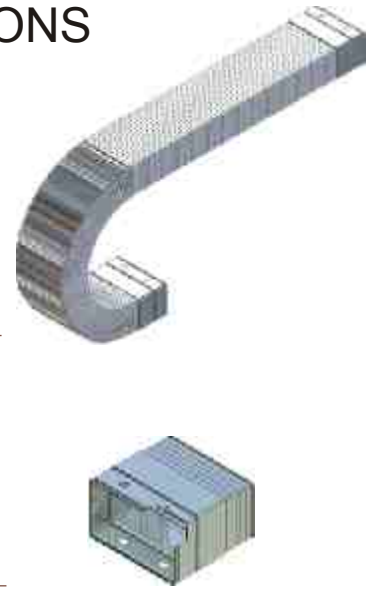
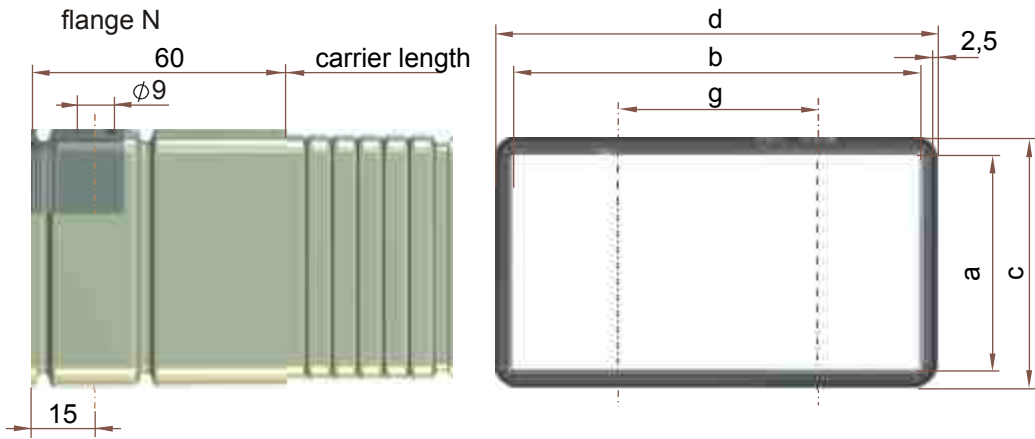

SFK	radius	a	b	c	d	g	k	p	z	weight kg/m
22 N	100 / 150	40	79	45	85	50	30,5	71	65	3.0
22 H	150 / 200	56	80	60	85	50	30,5	86	90	3.5
22 S	200	78	78	85	85	50	30,5	111	130	5.1
32 N	150 / 200	54	109	60	115	80	30,5	86	90	4.8
32 H	200 / 250	75	110	80	115	80	30,5	106	120	5.3
32 S	300	109	109	115	115	80	30,5	141	175	6.6

The order of length is equal to half the length of travel, plus four times bending radius:

$$L = L_v / 2 + 4 R$$

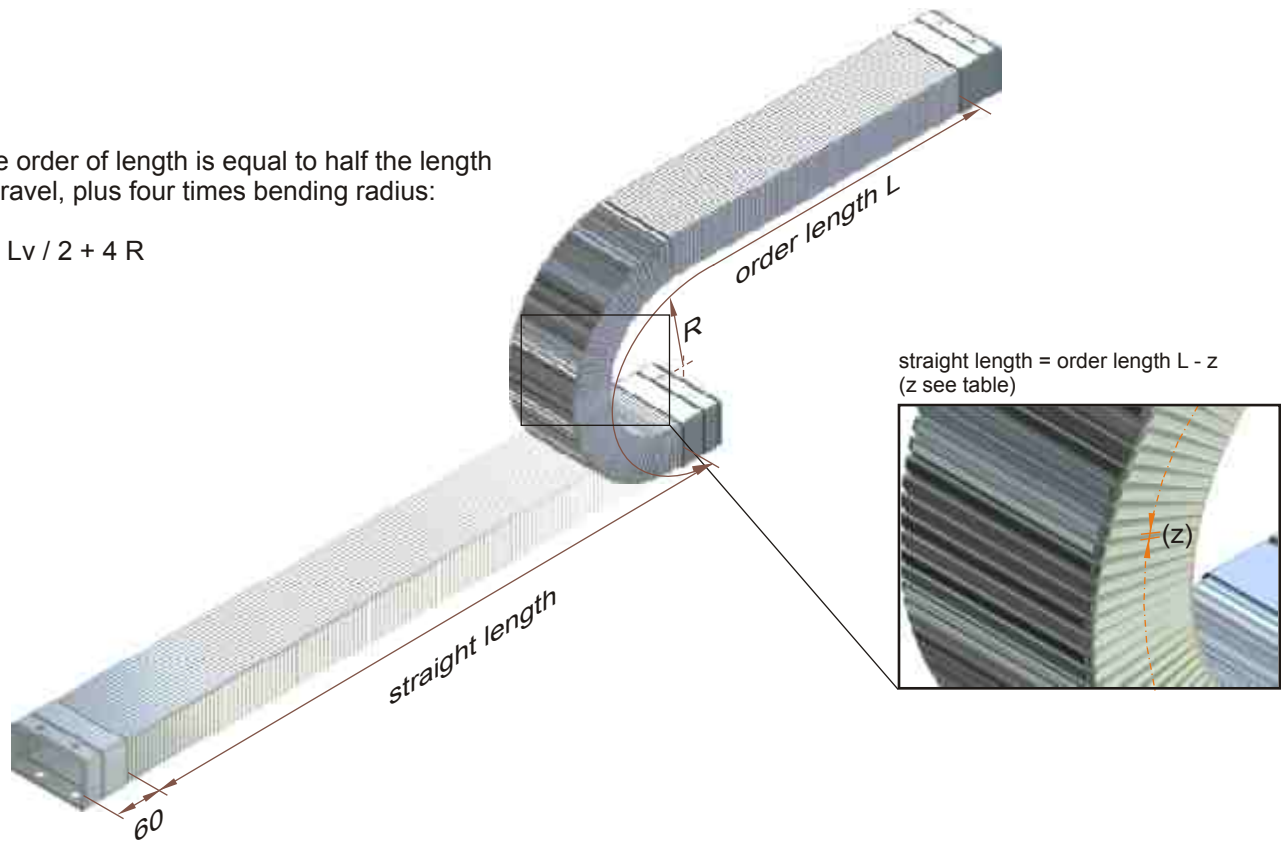

order example: max. travel distance 3 m, bending radius 100 mm, standard arrangement

SFK 32N / 100	x	1900	/	N/N
type / radius	x	length	/	connectors / arrangement

SFK Characteristics

The chain consists of a rectangular, galvanized steel spiral band and mounted in inner radius is a spring steel band. The SFK offers large usable cross-sections at low external dimensions and optimum line protection. At low cantilever lengths the SFK is ideal for areas with hot chips and sparks.

The temperature range is between -40° and $+180^{\circ}$ C.

SFK Flanges

Flange N

Standard is the low priced flange N, each with four mounting holes.

order example

SFK 32N / 250 x 3000 / NN / h
type / radius x length / flange / arrangement

Flange A

With countersunk screws, knurled nuts and angles the standard flange N changes to flange A.

order example

SFK 32N / 250 x 3000 / AA / h
type / radius x length / flange / arrangement

Flange B

Flange B is connected laterally with angles. The holes of standard flanges N are omitted.

order example

SFK 32N / 250 x 3000 / BB / h
type / radius x length / flange / arrangement

Scoop mount

Scoop mount complements the diversity of the possible connector types.

order example

SFK 32N / 250 x 3000 / S1 / h
type / radius x length / flange / arrangement

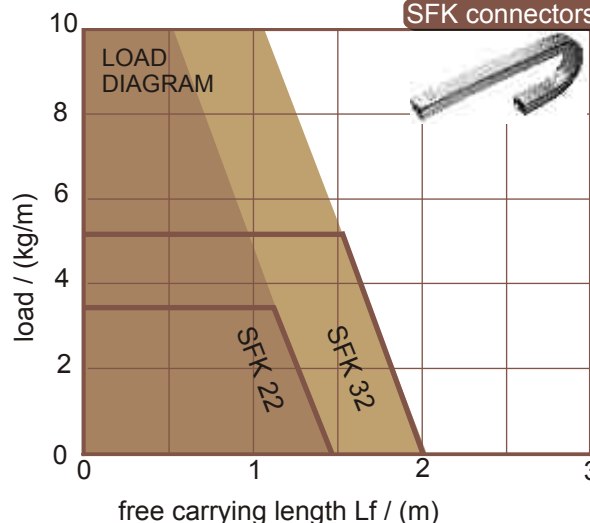

flange N

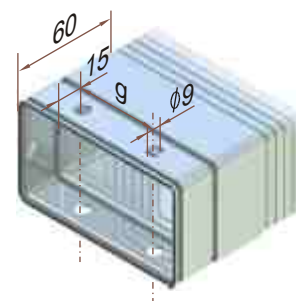

flange A

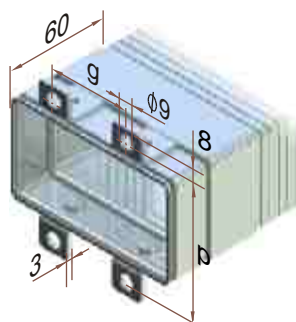

flange B

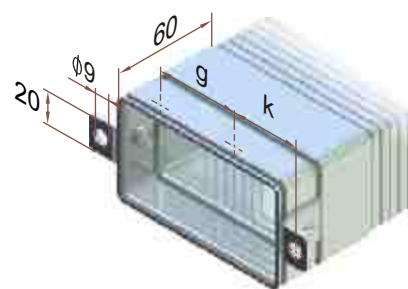

scoop bracket

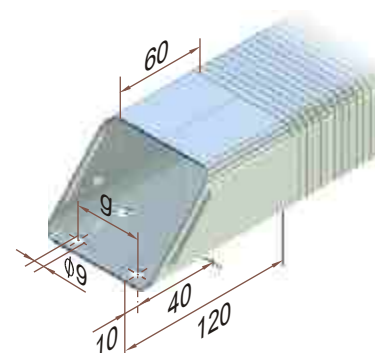

PFR

PFR dimensions 108

PFR connectors 109

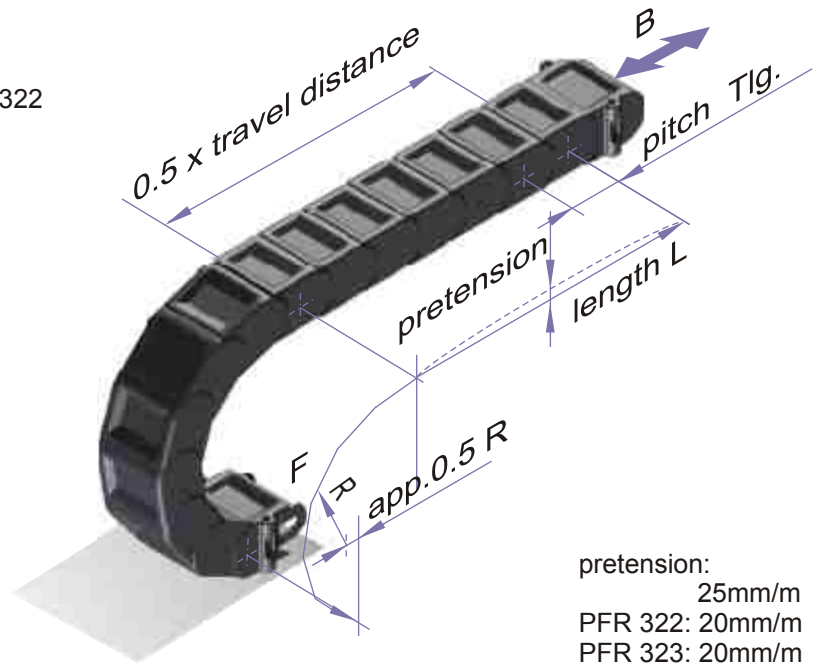
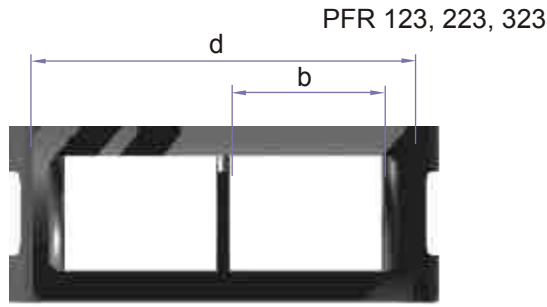
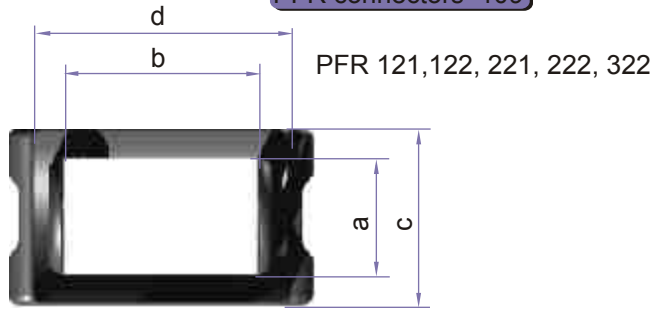

pretension:
25mm/m
PFR 322: 20mm/m
PFR 323: 20mm/m

PFR	radius	pitch	a	b	c	d	f	g	h	i	k	k _N	p	p _N	w	weight kg/m
121	75 / 150	35	23	23	35	35	6	0	5	9	5,5	61	25	61	20	0,7
122	75 / 150	35	23	38	35	50	6	20	5	9	5,5	56	25	61	20	1,2
123	75 / 150	35	23	30	35	75	6	45	5	9	5,5	56	25	61	20	1,5
221	100 / 200	50	34	36	50	50	8	20	6	11,5	5,5	56	40	76	25	1,6
222	100 / 200	50	34	86	50	100	8	70	6	11,5	5,5	56	40	76	25	2,1
223	100 / 200	50	34	66	50	150	8	120	6	11,5	5,5	56	40	76	25	2,8
322	150 / 300	65	57	134	75	150	10	120	8	15	5,5	56	65	101	35	3,2
323	150 / 300	65	57	103	75	225	10	195	8	15	5,5	56	65	101	35	4,6



Dismantling PFR

The pins (3x12mm) of the dismantling tools are inserted into the provided openings, dismantling tools compress and pull apart the carrier.

order example: travel 3 m, bend radius 200 mm, plastic connectors, arrangement hanging

PFR 222 / 200 x 2300 / K K / h
type / radius x length / connectors / arrangement

PFR characteristics

The plastic tube PFR is a closed design with excellent protection from dirt and damage caused by chips or the like. In the types PFR 123, 223 and 323 the cables are kept in two separate chambers.

PFR with metallic finish is a ekd specialty that mainly occurs in applications with hot chips and sparks. Due to the high surface temperature conductivity and scratch resistance there are no limits for this surface coating. In addition this type has an exceptionally high quality look with the shiny metallic surface.

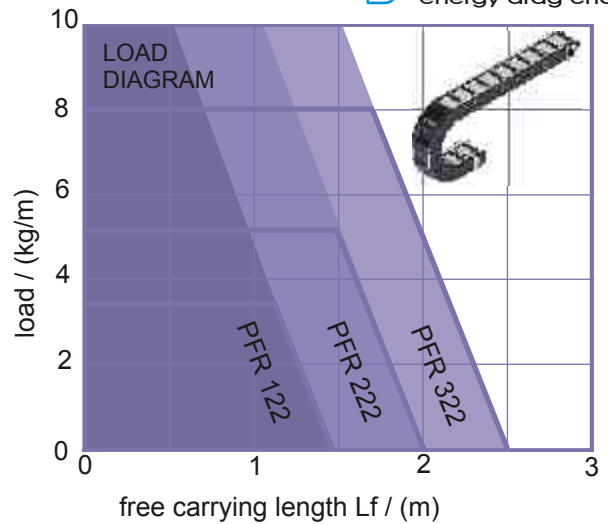

Plastic connector PFR

The plastic end connector can be installed at any point in the chain, whereby a portion of the tube can serve as a static line.

Order example:	plastic connector on both sides		
	PFR 121 / 75 x 1505	/KK	
	type	/radius x length	/connectors

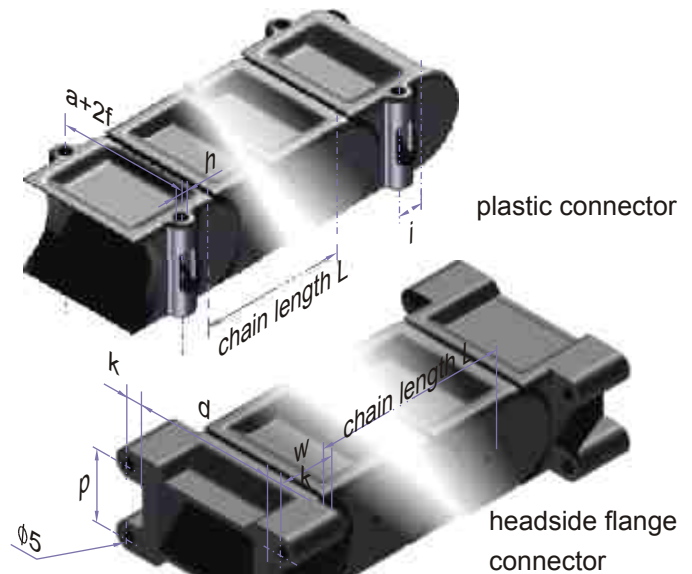

Headside flange connector PFR

The headside bracket is used for assembly on top or front of the machine. A combination of frontal and end connection is possible.

Order example:	plastic connector and headside flange		
	PFR 121 / 75 x 1505	/KSFA	
	type	/radius x length	/connectors

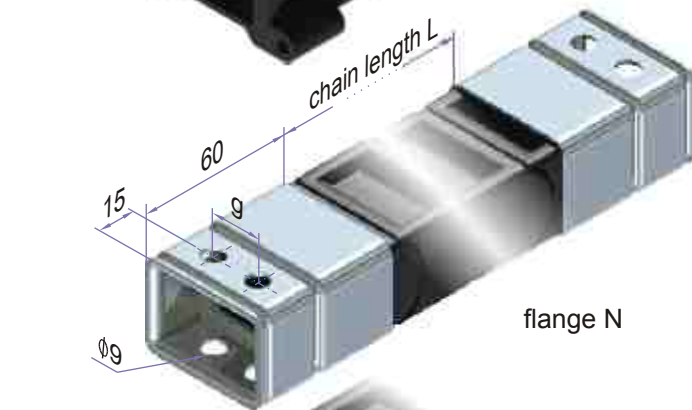

Normal flange (steel) brackets

Normal flanges made of steel can be supplied on request.

Ordering example:	N flange and flange A		
	PFR 121 / 75 x 1505	/NA	
	type	/radius x length	/connectors

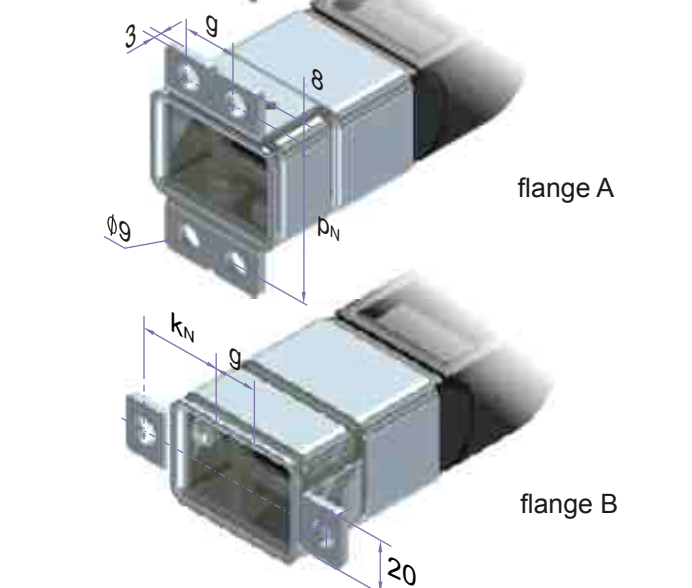

PFR

PFR galvanized



Guide troughs are necessary when a suitable surface for the unrolling of the energy chain is not present and to give guidance and support throughout the chain length.

gliding arrangement

The designing and assembling of the filing and guide channels should be handled with great care, because this is the only chance for a smooth operation of the system. ekd gelenkrohr manufactures troughs for all applications made of steel (galvanized), stainless steel or aluminum. The individual channel segments are mounted with connecting elements.

Trough for steel chains

Troughs for steel chains are made of edged groove angles that are bolted directly on the floor or on the corresponding substructures.

Steel-trough

The steel-trough is universally applicable. Besides the standard channel steel troughs (galvanized). Special dimensions and stainless steel guide troughs are available.

A simple on-site assembly is guaranteed by the top-hat profiles on which the trough segments can be accurately aligned. For this first preassembly the connection angle is finger tight then screw on the angles with the welded inserts. Then the groove is aligned and the connection angle can be fixed.

For gliding applications the angles are supplied with mounted slide bars.

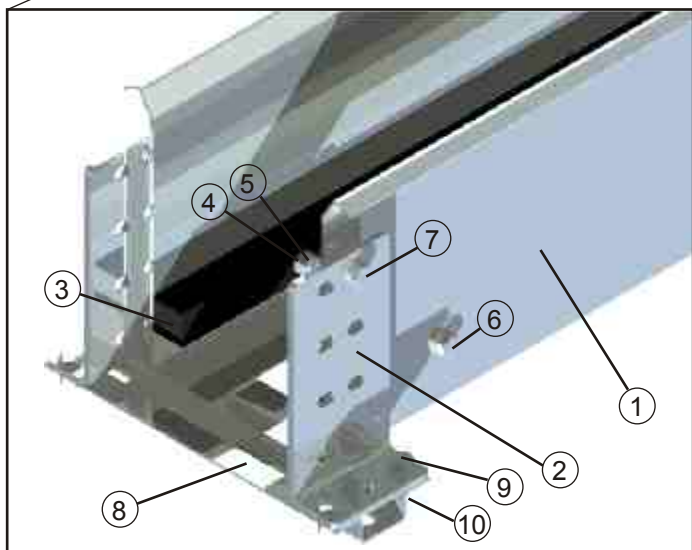
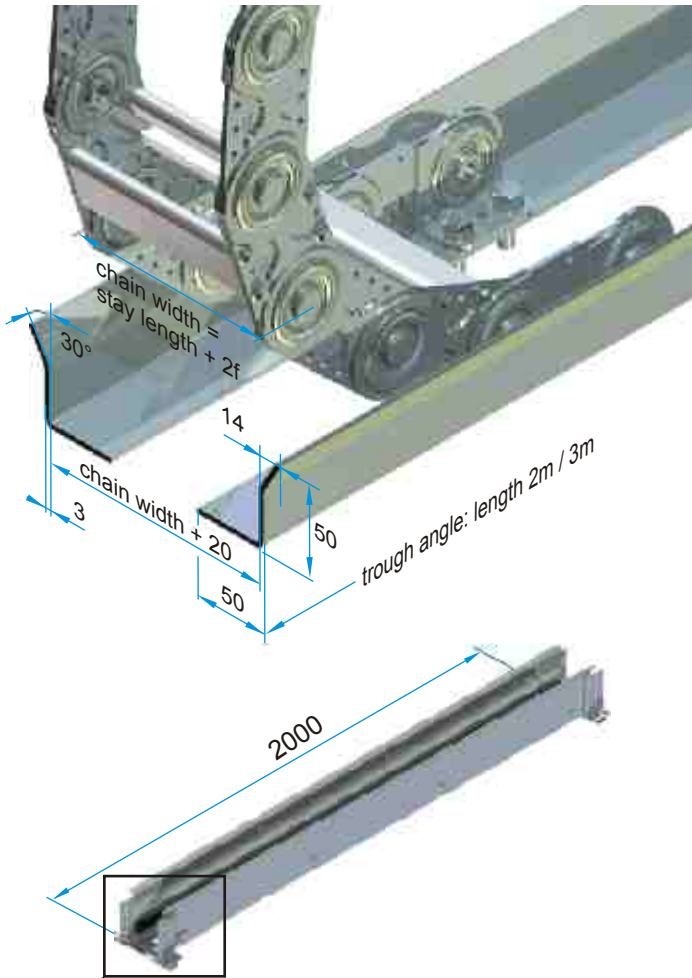

item	name	weight [kg/m]		
		height 2mm	3mm	
1	trough angle 2mm ¹⁾			
2	connection angle ²⁾	100	4.1	5.5
3	slide bar 25x25x2000			
4	washer DIN 125	150	5.3	7.2
5	nut M8 DIN 985			
6	DIN 931 M8x40	200	6.5	8.8
7	DIN 931 M8x12			
8	hat profile	250	7.7	10.4
9	DIN 931 M8x16			(weight incl. slide bar)
10	nut M8			(slide bar 25x25 0.6kg/m)

1) standard heights 100 / 150 / 200/250, L=2000mm, alternative L=3000mm, t= 3 mm
2) connection angles 40 / 80 / 120 / 160 / 200
3m standard height 200

Aluminum trough

The aluminum trough (trough height 120mm) is perfectly adapted to floor assembly for long travels with energy chains of the type Kolibri.

Constructed with 3 m long channel segments, the width corresponds to the chain size, a fast and easy installation is performed. The connection of the single channel segments is with center bolts.

The first half of travel is fitted with gliding bars so that a smooth transition at the fixed connector (usually mid-travel) is guaranteed.

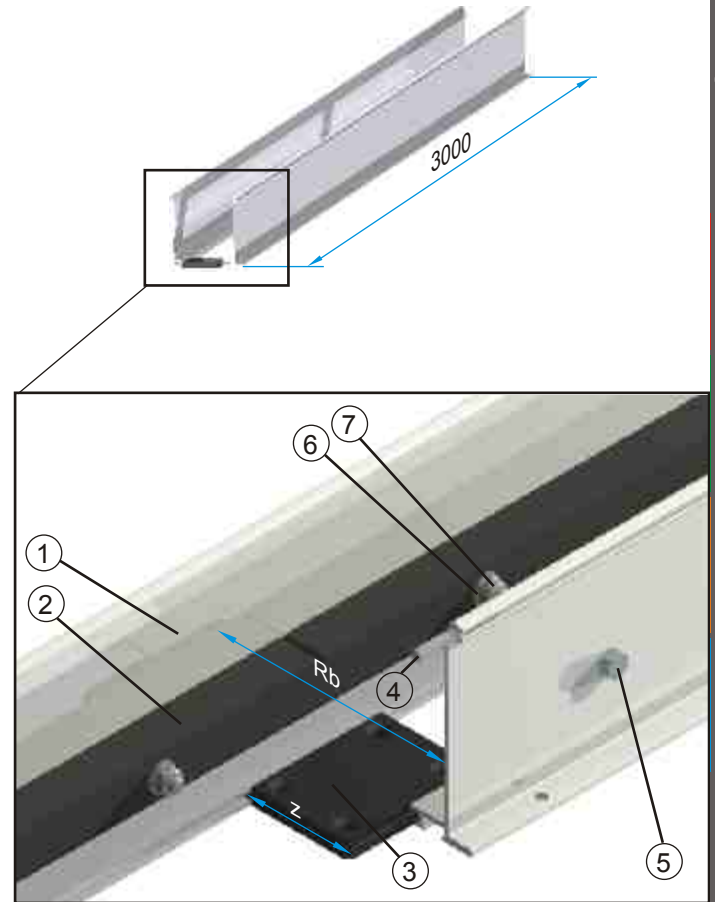

item	name	part no.	weight [kg]
	aluminium tough	1361	
1	alu-trough angle 120x3000	-	3.5
2	slide bar 20x20x3000	1606	1.2
3	distance profile DP (s.b.)	(s.b.)	(s.b.)
4	groov. pin DIN1474 6x40	-	0.008
5	screw DIN 931 M6 x 35	-	0.010
6	washer DIN 125 - 1 A6	-	0.001
7	nut DIN 987 M6	-	0.004

distance profiles for aluminium troughs						
Rb	name	part no.	energy chain ¹⁾	c x d ²⁾	z	[kg]
54	DP 54	1367	Kolibri 30.050.X	30 x 50	20	0.017
64	DP 64	1551	Kolibri 30.060.X	30 x 60	30	0.020
66	DP 66	1368	Kolibri 40.062.X	40 x 62	32	0.022
70	DP 70	1552	Kolibri 50.065.X	50 x 65	36	0.026
80	DP 80	1553	Kolibri 40.075.X	40 x 75	46	0.037
84	DP 84	1554	Kolibri 30.080.X	30 x 80	50	0.042
100	DP100	1369	Kolibri XX.095.X	30 x 95, 50 x 95	66	0.059
130	DP130	1555	Kolibri XX.125.X	30 / 40 / 50 x 125	96	0.092
154	DP154	1556	Kolibri 50.150.X	50 x 150	120	0.118
116	DP116	1557	PKK 210 stay 90	50 x 110	82	0.076
160	DP160		PKK 228 stay 120	55 x 156	126	0.124
210	DP210	1558	PKK 228 stay 170	55 x 206	176	0.179

1) example arrangement. Other energy chains can also be used with corresponding outside dimensions.
2) Outside dimensions of the energy chain

TROUGHS

dimensions steel trough

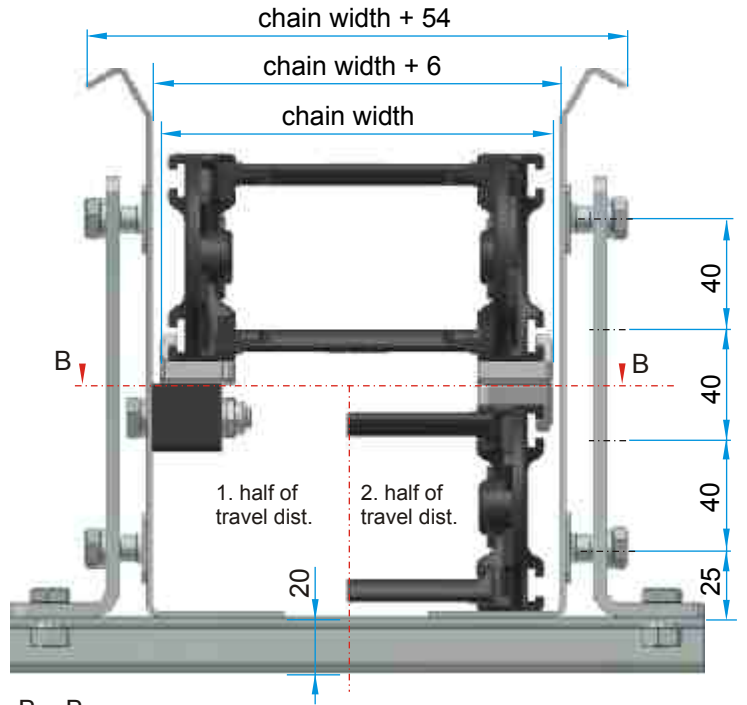

dimensions steel trough:
the height of the trough angle depends on the energy chain used:
example: PKK 328

trough angle height 200 mm
connector angle height 160 mm

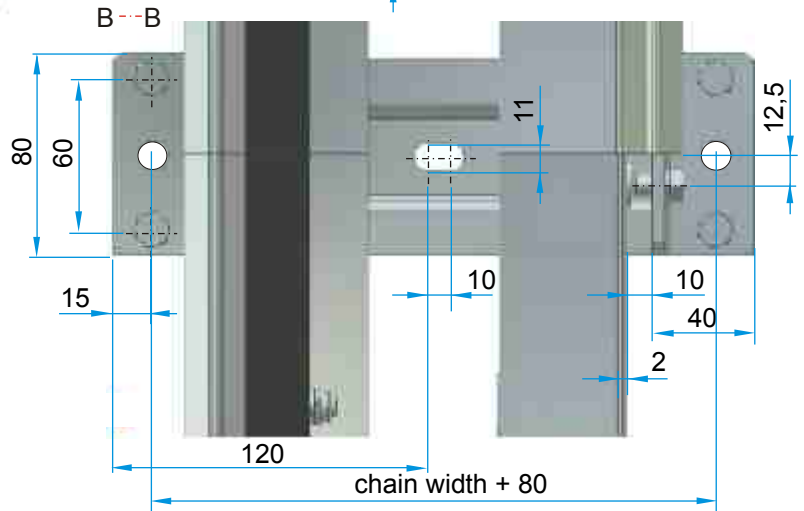

dimensions aluminium trough:

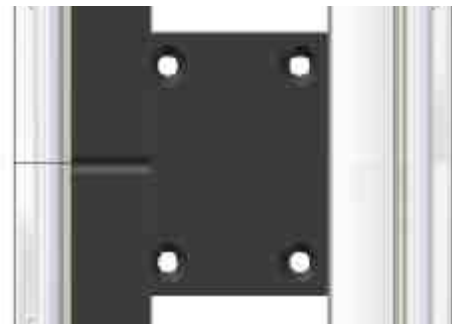
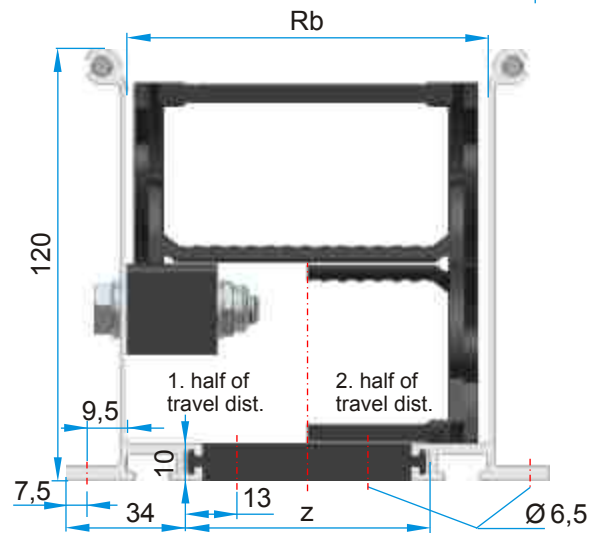
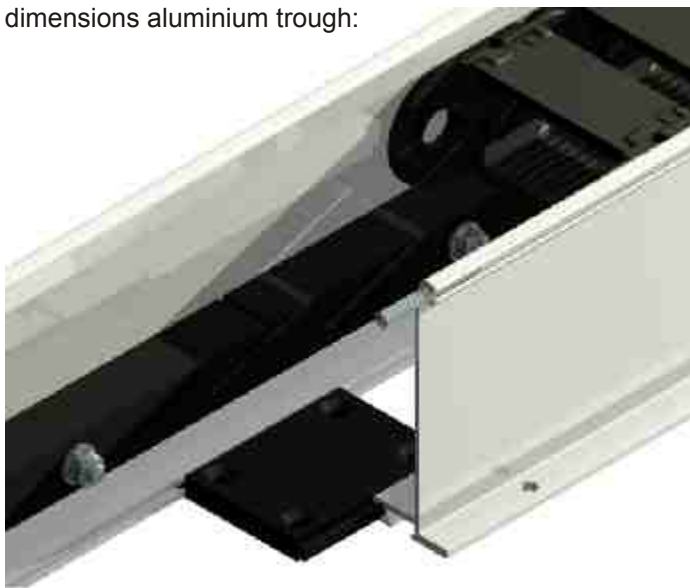

Gliding arrangements

For travels up to about 60 meters, speeds of $v_{max} = 1.5 \text{ m/s}$ and accelerations of a $a_{max} = 1 \text{ m/s}^2$ energy chains and troughs can be used.

Exceeding these values contact ekd gelenkrohr when planning your application.

The upper part of the chain runs up to half of the travel on slide bars that are bolted to the channel segments.

For long travels and heavy chains a lower connector assembling is required to guide driver initiated forces in the energy chain direction. A reduction to the height of the chain radius is usually sufficient.

The fixed connector area is designed to ensure a smooth transition of the energy chain. In addition, the slide bars in the end zone are contour adjusted. The energy chain can be attached separately with a countersunk screw or be mounted together with the slide bar. In addition, the glide bar must be provided with a corresponding reduction.

Lower connectors need an additional chain length:

Not to burden the energy chain in the end position some (according to the application) chain links have to be fitted with an reverse bending radius, so that the driver stops at a sufficient distance in front of the chain bow end.

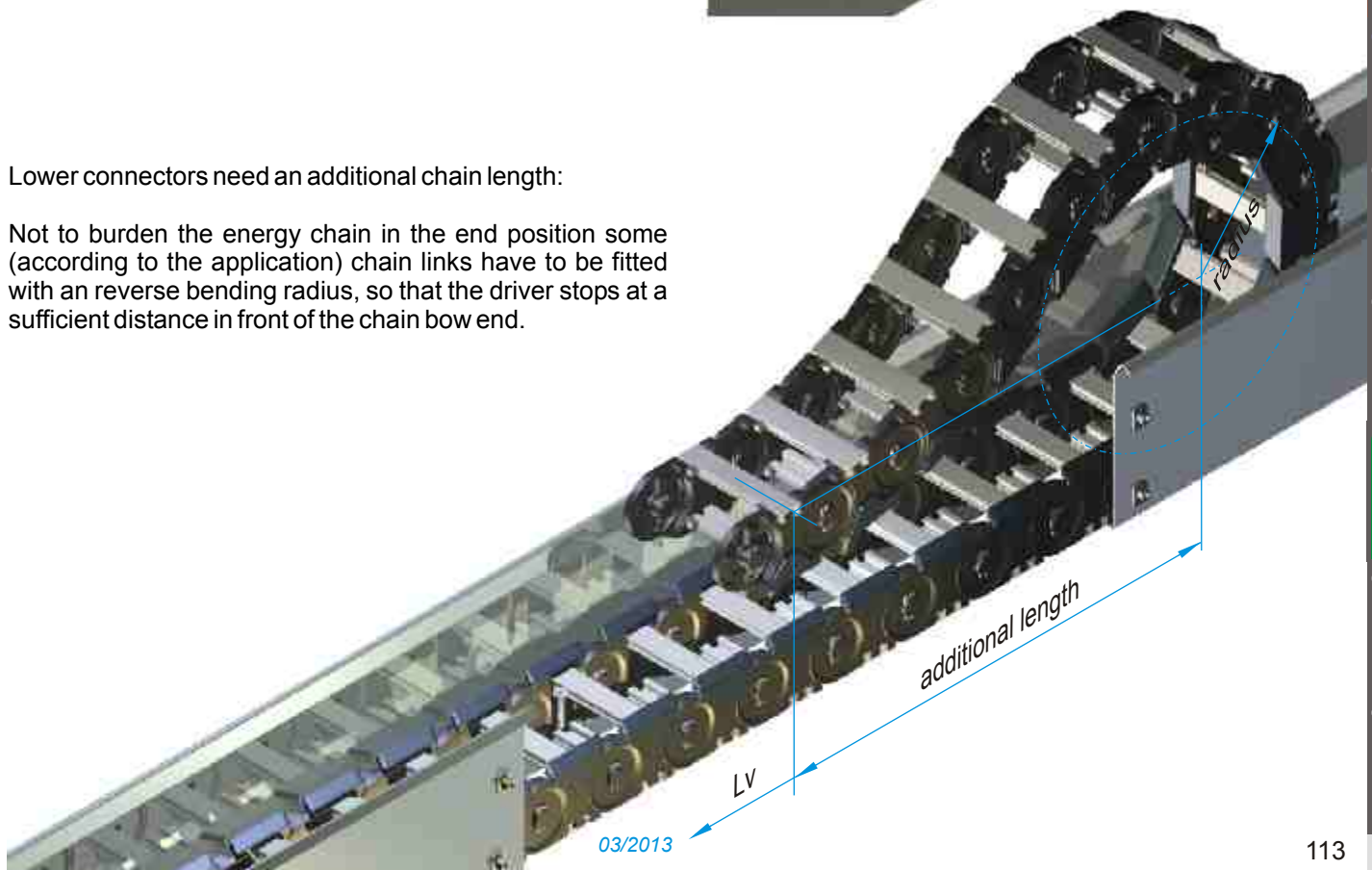
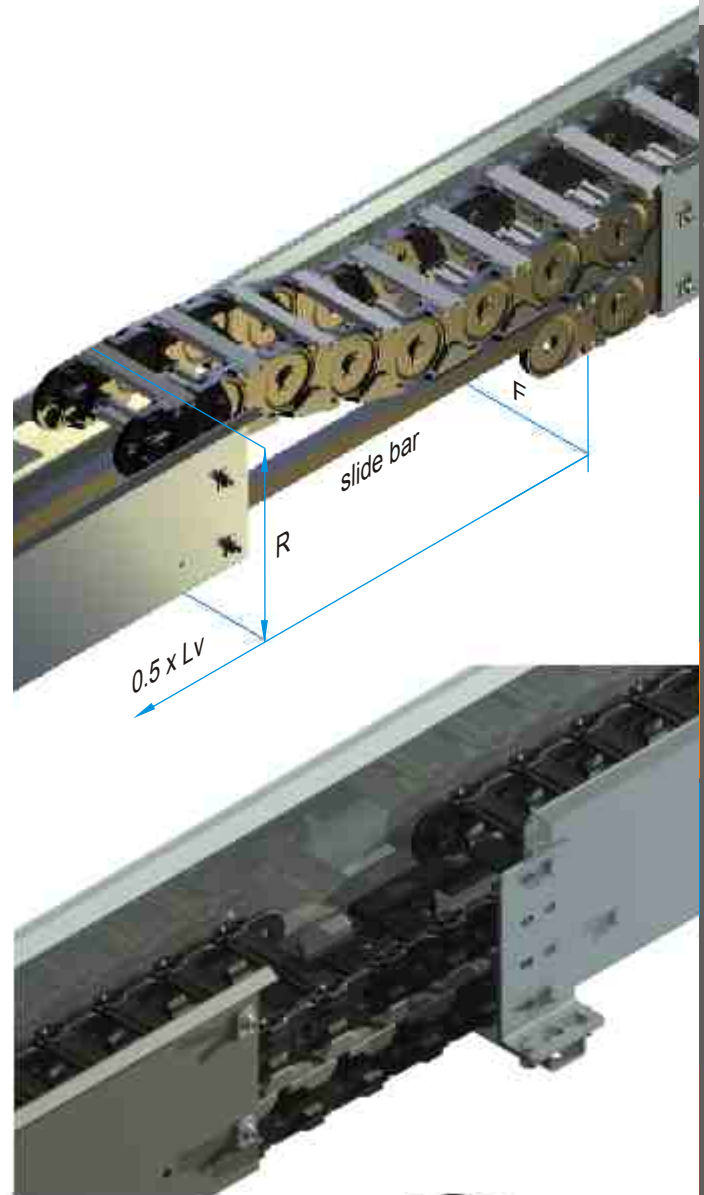

ENERGY CHAIN SYSTEMS are called components, modules or complete items ready for connection.

ekd energy chain systems are offered as a service package with all necessary planning and realization steps through to testing and production release.

This usually begins with the definition of the requirements in the travel distance, number of cycles other factors, such as environmental conditions and media influences and the available design space. From this data the amount and type of cables, their connections and the energy chain can be specified.

Cables

ekd gelenkrohr as a system supplier cooperates with all leading cable manufacturers (Lapp, Lütze, Nexans, SAB Bröckskes etc.). According to customer specifications ekd can work out an efficient and price-optimized solution in the system - whether power, bus, hybrid, or special cables with or without connectors.

The same applies to hydraulic lines. Standards and standard components are scheduled as early as the design phase, as well functional as cost-optimized.

Energy chains

The selection and design of an optimized energy chain or where the application requires a custom-tailored solution is based on decades of experience.

System

With the creation of individual strain relief systems, guide rails, troughs and enclosures the projects are completed to ready-assembly systems - including accompanying documentation.

Transit, maintenance and service

The complete assembly is shipped or after consultation with customer be installed by experienced ekd assemblers on site. Maintenance and service remains in the hands of customer or can be arranged individually.

The result is a flat rate for the energy guiding system, which frees the user of logistics, efforts and cost overruns.



Pos.	Art-Nr.	Bezeichnung	Norm / Zeichnung	Material	Anzahl
1	1380	PKK 211/00x1500/120	Katalog		(1)
1.1	1300	Lasche PKK 210 R100		PKK GF35	42
1.2	0384	PKK 220 Steg 120		PKK GF35	42
1.3	0404	PKK 220 Spezialsteig		PKK GF35	42
2		Zugentlastungsblock	C-09-BM-47011		(2)
2.1		Außenprofil		Aluminium	4
2.2		Mitteprofil		Aluminium	2
2.3		Schraube		Stlz	4
3		Mittelmeergehäuse	C-09-BM-47012		(1)
3.1		Gehäuseblech		Stlz	1
3.2		Beleuchtungsansatz		Stlz	2
3.3		Schraube		Stlz	6
4		Führungsrinne	C-09-BM-47013		(1)
4.1		Rinnenblech		Stlz	1
4.2		Bodenblech		Stlz	1
5		Medienversorgung			(1)
5.1		Medienlsg. mit Anschluss	C-09-BM-47014		4
6		Leitungsbegleitung			(1)
6.1		Daten- und Sensorlsg.	C-09-BM-47015	Aluminium	2
6.2		Versorgung (elekt.)	C-09-BM-47016		2
6.3		Hydraulikleitungen	C-09-BM-47017		7

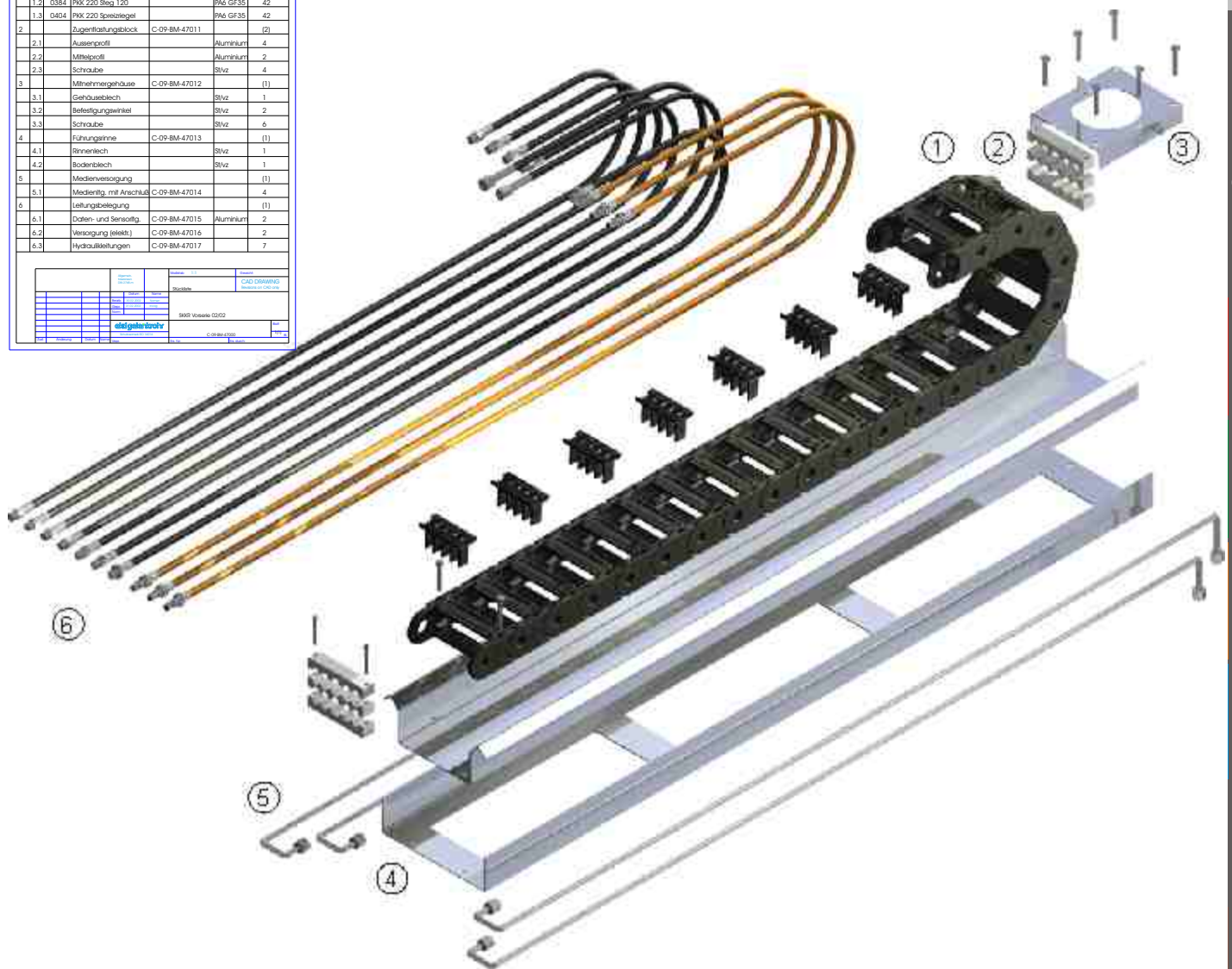

applications:

cranes, telescopic systems, handling equipment





example train wash:
free weathering
extreme influence of media (detergents)
travel 180 m

The SYSTEM MARATHON is designed for long travel distances with a rolling-led energy chain.

The upper part of the chain runs with roller sets on a continuous flat guiding rail surface. This construction avoids completely the sliding friction between the upper and lower strand of conventional energy chains. In this movement only substantially lower rolling friction occurs.

In front of the chain radius the roller sets are lifted out of the guide rail. In the chain radius the roller sets are pivoted into the trough by means of polygonal shape and the chain is lowered in the trough.

In the opposite direction of travel the roller sets behind the chain radius swirl again, embrace the guide rail and carry the upper strand centered within the trough.

Measurements for the SYSTEM MARATHON confirmed that the reduction of friction forces is up to 90%. Increased starting torque, as with sliding applications and the overcoming of static friction after a stop will not appear with this system.

Not least of all SYSTEM MARATHON minimizes wear through the rolling friction.

Another advantage is the parallel to the chain running force of the movable driver and the straight arrangement of the upper run which totally avoids changing bending of the lines and the energy chain. A substantially increased durability and reliability are the result.



example greenhouse:
relative humidity 80-100%
travel 150 m

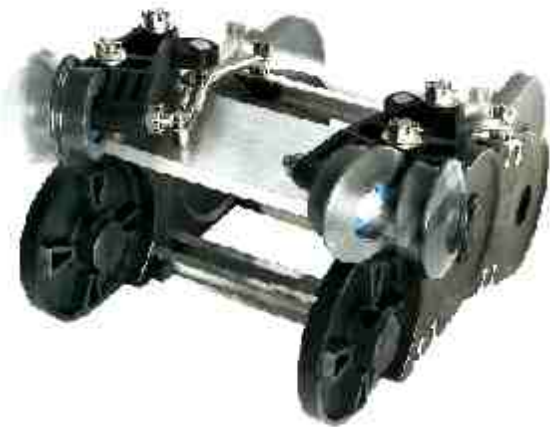



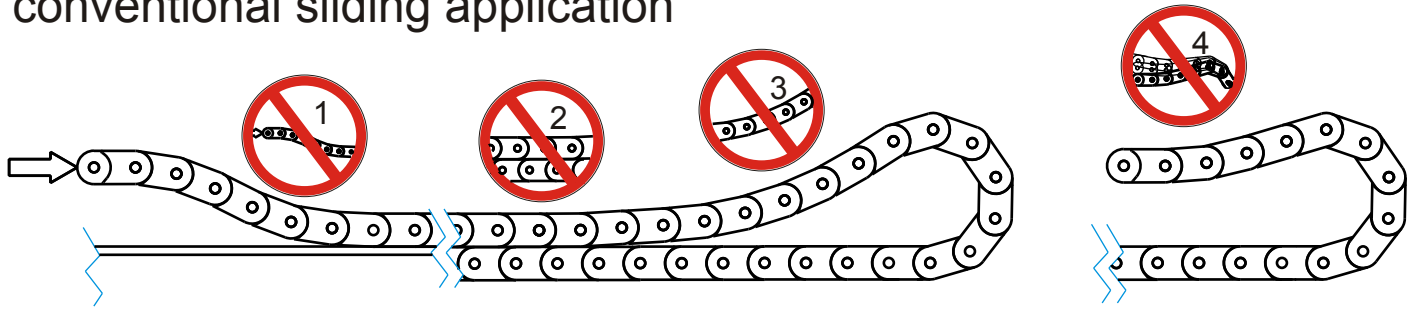

conventional sliding application

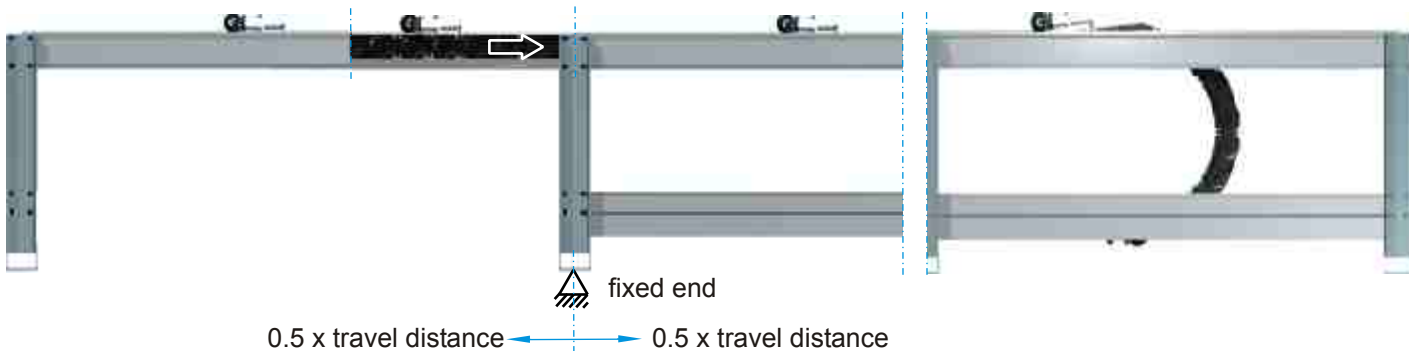

SYSTEM MARATHON



-  of force not in energy chain direction
high-flexing of the energy chain
repeated bending of the lines
-  sliding friction: high forces
high starting torque
abrasion, wear, noise
-  bending of the energy chain and
the lines
-  oscillations lead to extreme
loads of the energy chain
additional lengths often necessary

SYSTEM MARATHON

moving forces reduced by up to 90%
forces into the direction of energy chain
no repeated bending
no increased starting torques
abrasion and wear-minimizing

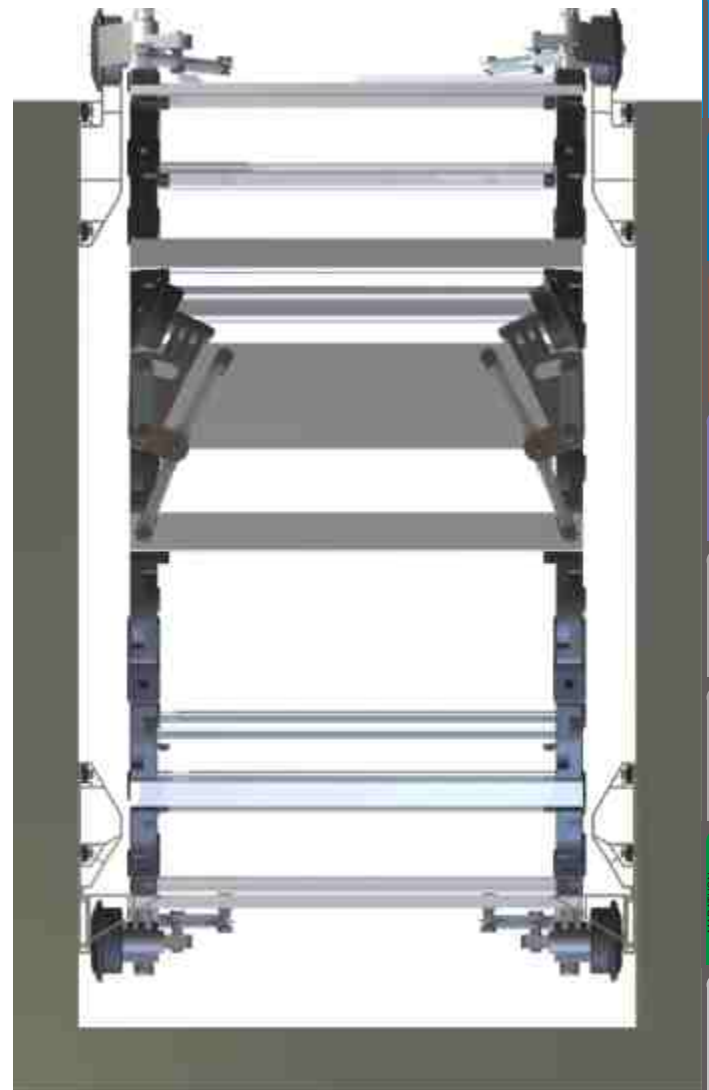

Standard energy chains do not allow lateral displacements or torsion movements. They are made of rigid material with the set on maximum unsupported length and show a straight, hard running. The energy chains SYSTEM ALLROUND open new opportunities.

By using a highly flexible link-material (thermoset elastomer) offers SYSTEM ALLROUND countless exercise options without additional design efforts.

The high flexibility of the SYSTEM ALLROUND makes the combination of several movements. The combination of two linear motion is a possible.

Just as well combined rotary or oscillating movements may overlap to simple linear movements. Thus, if there is sufficient chain length, lateral pivoting movements of 90° and axial rotation of 180° are achieved.

An almost limitless range of motion is given in a hanging arrangement at sufficient chain length.

Practical examples demonstrate the versatility of the SYSTEMALLROUND:

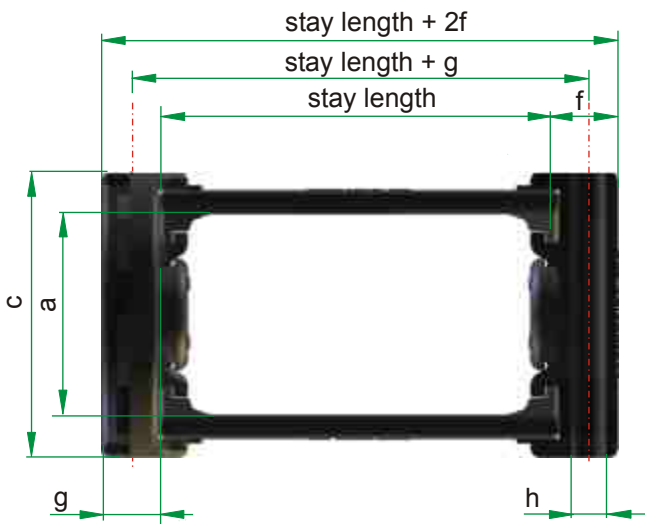

ALLROUND	bend radius R	pitch	a	c	f	g	stay length [mm]
PKK 210	65 75 100 125 150 200 300	65	34	50	10	10	50...200 (see PKK)
PKK 240	75 100 150 200 300	65	44	60	10	10	50...200 (see PKK)
PKK 310	100 130 150 200 300 400	90	51	75	12	12	50...300 (see PKK)
PKK 340	100 130 150 200 300 400	90	60	85	12	15	50...300 (see PKK)
PKK 520	150 200 300 400 500	115	80	104	20	14	50...300 (see PKK)

The connector links of the SYSTEM ALLROUND are manufactured in the standard material PA 6 GF 35. A combination of standard links and ALLROUND links achieve applications with specific features are available on request.

order example:

PKK 220 / 200 x 3510 / 100 ALLROUND
type radius X length / stay variant

SYSTEM ELTOLA

ELastic TOrsion LA bearing is the combination of noiseless and low wear. The elastic torsion bearing replaces the conventional chains existing sliding pivot with a friction free connection. The relative movement between adjacent links is guided over the elastic torsion bearing.

In the angular motion is through this design with ELTOLA a torque transferred between the adjacent chain links, which increases starting from the neutral zero position with increasing twist angle. As a result a progressive damping of the polygon movement and a low noise, extremely quiet running is achieved.

All ekd plastic chains may be equipped with the SYSTEM ELTOLA.

ELTOLA is designed for applications with fast and noise-sensitive and large acceleration movements.



order example:

PKK 220 / 200 x 3510 / 100 ELTOLA
type / radius x length / stay length variant

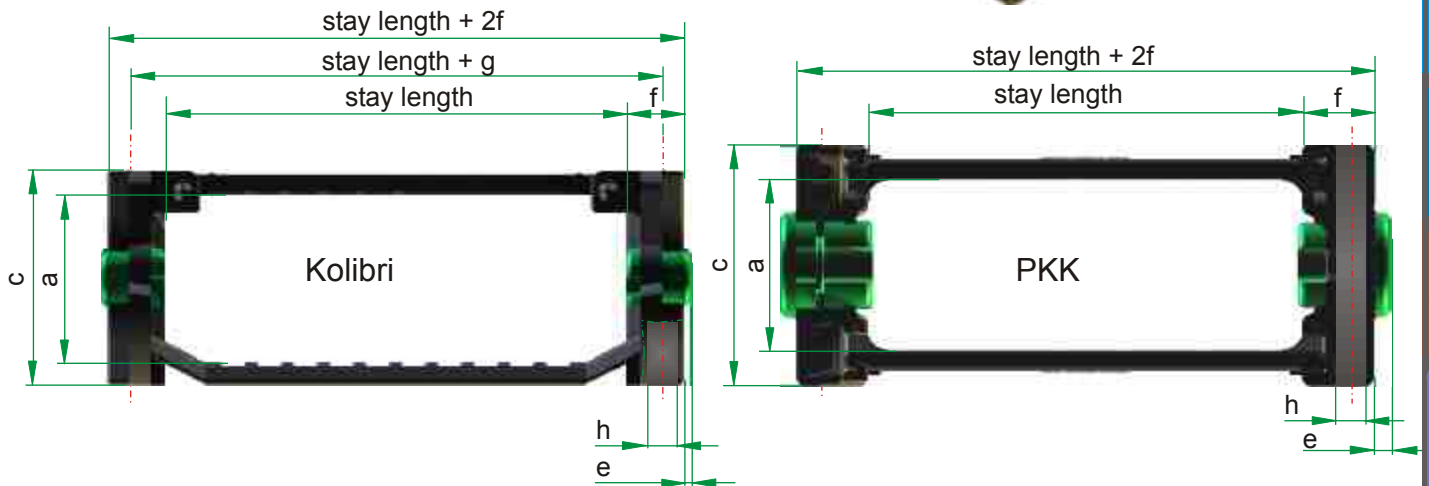

ELTOLA	bend radius R		pitch	a	b	c	d	e	f	g	h	stay length [mm]
Kolibri 30.050	75	100	35	23	34	30	50	1	-	40	5	-
Kolibri 30.060	75	100	35	23	44	30	50	1	-	40	5	-
Kolibri 30.080	75	100	35	23	64	30	50	1	-	40	5	-
Kolibri 30.095	75	100	35	23	79	30	50	1	-	40	5	-
Kolibri 30.125	75	100	35	23	109	30	50	1	-	40	5	-
Kolibri 40.062	75	100	45	29	47	40	62	1	-	54	5	-
Kolibri 40.075	75	100	45	29	60	40	75	1	-	67	5	-
PKK 210, 220	75	100	65	34	-	50	-	2	15	10	6	50...200 (see PKK)
PKK 240	75	100	65	44	-	60	-	2	10	10	6	50...200 (see PKK)
PKK 310	100	130	90	51	-	75	-	3	12	12	8	50...300 (see PKK)
PKK 340	100	130	90	60	-	85	-	3	15	15	8	50...300 (see PKK)

SYSTEM REINTEC

The principle of the energy chain **REINTEC** is the avoidance of friction at the links and pins of conventional chains through a friction free connection:

The relative movement between the chain links is guided over the torsion bearing **ELTOLA** that positively connects links and is made of a special material. The links are spaced apart, thus preventing wear and abrasion.

REINTEC has significant advantages in comparison to known energy chains:

- abrasion and wear are optimized while maintaining the stability equal to standard cable chain
- quiet running through progressive torsion force

applications:

chip technology, food and textiles, painting and others.



ELTOLA



Fraunhofer
TESTED
DEVICE[®]

ekd gelenkrohr „Reintec“
Report No. EG 0111-250

IPA-Qualifizierungsurkunde

Hiermit wird bescheinigt, daß für untenstehendes Produkt des Unternehmens
ekd gelenkrohr GmbH

Steinhof 47
D-40699 Erkrath

das IPA-Qualifizierungsiegel mit der Bericht-Nummer EG 0111-250 vergeben wurde.

Die Energieführungskette der ekd gelenkrohr GmbH des Typs „Reintec“ ist bei den Vorfahrtgeschwindigkeiten $v=0,2$ m/s $v=0,6$ m/s, $v_0 = 1,4$ m/s und $v = 2,8$ m/s geeignet, um in Reibräumen der Luftreinheitsklasse „Class T“ (nach US Federal Standard 209F) eingesetzt zu werden.

Detaillierte Informationen sowie die Parameter der Blumgebung entnehmen Sie bitte dem IPA-Bericht der Fraunhofer-Gesellschaft.

Bescheinigt am 21. November 2001.

Die zeitliche Gültigkeit dieser Bescheinigung ist unbegrenzt. Weitere Informationen finden Sie auf der Website <http://www.ipa-qualification.com>

Stuttgart, den 21. November 2001



Unbeschrift

Fraunhofer
Institut
Produktionstechnik und
Automatisierung

order example:

Kolibri 30.050.0 / 100 x 3500	REINTEC
type / radius x length	variant

Fraunhofer Institut für Produktionstechnik und Automatisierung classified a system of energy chain and cables as class 1 according to DIN EN ISO 14644-1.

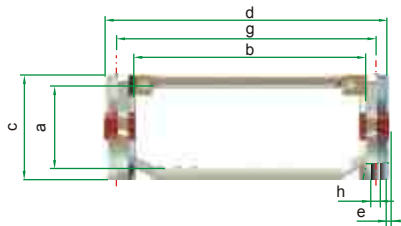

SYSTEM REINTEC	bend radius R					pitch	a	b	c	d	e	f	g	h
Kolibri 30.050.0	75	100	150	200	35	23	34	30	50	1	-	40	5	
Kolibri 30.060.0	75	100	150	200	35	23	44	30	60	1	-	50	5	
Kolibri 30.080.0	75	100	150	200	35	23	64	30	80	1	-	70	5	
Kolibri 30.095.0	75	100	150	200	35	23	79	30	95	1	-	85	5	
Kolibri 30.125.0	75	100	150	200	35	23	109	30	125	1	-	115	5	
Kolibri 40.062.0	75	100	150	200	45	29	47	40	62	1	-	54	5	
Kolibri 40.075.0	75	100	150	200	45	29	60	40	75	1	-	67	5	

classification		maximum allowed particle concentration acc DIN EN 14644-1 with particle dimensions																	
DIN EN ISO 14644-1	EG-GMP "at rest"	EG-GMP "in operation"	US Fed. Standard 209E*	0,1 µm		0,2 µm		0,3 µm		0,5 µm		1,0 µm		5,0 µm					
1	2	3	4	5	6	7	8	9	pro m³	pro cbf	pro m³	pro cbf	pro m³	pro cbf	pro m³	pro cbf	pro m³	pro cbf	
									10	0,3	2	0,1							
2									100	3	24	1	0,3	4	0,1				
3			1						1,000	30	237	7	102	3	35	1	8	0,2	
4			10						1,240	35	265	8	105	3	35	1			
	A/B	A							10,000	300	2,370	67	1,020	29	352	9,9	83	2	
									12,000	340	2,650	75	1,060	29	353	10			
									100,000	2,833	23,700	671	10,200	289	3,520	100	832	24	
															3,520	100			
															3,520	100			
															3,530	100			
									1,000,000	28,329	237,000	671	102,000	2,890	35,200	997	8,320	235	
															35,300	1,000			
															352,000	9,972	83,200	2,357	
															352,000	9,972	2,900	82	
															352,000	9,972	2,900	82	
															353,000	10,000	2,470	70	
															3,520,000	99,716	832,000	23,569	
															3,520,000	99,716	29,300	830	
															3,520,000	99,716	29,000	821	
															3,530,000	99,716	29,000	821	
															3,530,000	100,000	24,700	700	
															35,200,000	997,167	8,320,000	235,694	
															35,300,000	1,000	293,000	247	
															352,000	9,972	2,930	83	
															352,000	9,972	2,900	82	
															352,000	9,972	2,900	82	
															353,000	10,000	2,470	70	
															3,520,000	99,716	29,300	830	
															3,520,000	99,716	29,000	821	
															3,530,000	99,716	29,000	821	
															3,530,000	100,000	24,700	700	
															35,200,000	997,167	8,320,000	235,694	
															35,300,000	1,000	293,000	247	
															352,000	9,972	2,930	83	
															352,000	9,972	2,900	82	
															352,000	9,972	2,900	82	
															353,000	10,000	2,470	70	
															3,520,000	99,716	29,300	830	
															3,520,000	99,716	29,000	821	
															3,530,000	99,716	29,000	821	
															3,530,000	100,000	24,700	700	
															35,200,000	997,167	8,320,000	235,694	
															35,300,000	1,000	293,000	247	

source: Fraunhofer Institut Produktionstechnik und Automatisierung (Fraunhofer IPA), Stuttgart, 2008

ekd energy chains are made from high quality materials according to ekd specified material minimum values. Continuous Inspection of incoming and outgoing goods in connection with the requirements of the ISO 9001 quality management system guarantee a consistently high reliability.

Environmental aspects are taken into account by complying with specified regulations for the selection of materials and manufacturing processes (RoHS directive 2002/95/EC, directive 2006/122/EC PFOS, RL 1907/2006/EC REACh).

Furthermore there are negative listings (absence lists) for environmentally hazardous substances to prevent bring in the market of so-called problem substances.

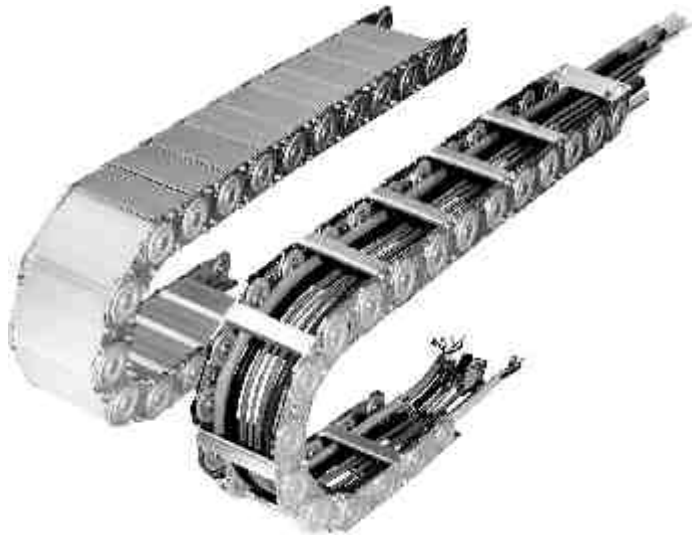

STEEL galvanized



STEEL hardened carburated

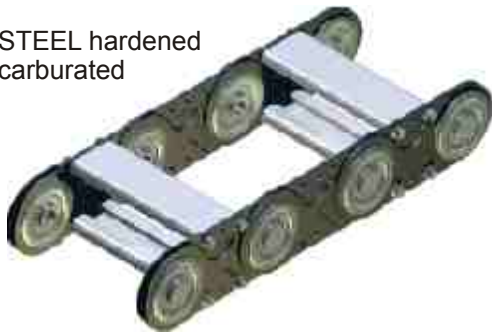

STAINLESS STEEL



Energy chains made of steel

Galvanized steel

ekd energy chains are made of high strength steel with a minimum tensile strength of 560 N/mm^2 ($R_m > 560 \text{ N/mm}^2$) and standard electroplated galvanized.

Stays and covers (**silver star**) consist of a seawater-resistant aluminum alloy (Al Mg Si 0.5).

Steel hardened (carburated)

Steel chains with high dynamic loads (eg when traversing over 1 m/s) are manufactured in hardened version. Through the special surface hardening process a very good wear resistance combined with high toughness of the energy chain is reached. This also results in an excellent and free of pollutants corrosion protection. Specially in the case of high cycle numbers hardened (carburated) links lead to longer life times.

Visual differences between the chains of the galvanized steel chains is a dark, pale appearance of the links. In this version, stainless steel screws and bolts should be used, too. The retaining rings are made of a bronze alloy.

Stainless steel

For extreme demands on corrosion resistance (eg, sea water resistance) this energy chains are made of a suitable stainless steel.

Energy chains made of steel and stainless steel are suitable for operating temperatures from -40°C to 400°C .

Plastic energy chains

ekd plastic energy chains are manufactured from high quality polyamide. In addition the series PLE with stays of seawater resistant aluminum and chains made of the plastic Kolibri and PKK are in the product range.

The standard material is polyamide 6 reinforced with 35% glass fibres (PA 6 GF 35). The continuous service temperature range for energy chains made of this material is -20 ° C to 100 ° C. Outside these limits a significant decrease in the mechanical strength characteristics must be expected. A detailed design is then essential.

The resistance to environmental influences is generally very good except for concentrated acids and bases, see chapter chemical resistance. Depending on the order, polyolefins can be used that provide chemical resistance in a wide range of applications.

For special applications, the material is modified:

High impact (HI), food applications (FDO), flame retardant (V-0), for explosion-endangered areas (EX) or against electrostatic discharges (ESD).

To optimize the flexibility energy chains they are manufactured from non-reinforced polyamide 6 and polyamide 66, and thermoplastic elastomers (SYSTEM ALLROUND).

With a combination of special construction and material properties in particular for clean room applications excellent technical results are achieved (SYSTEM REINTEC).

All components of the plastic energy chains are made of thermoplastic materials that are recyclable.

Plastic energy chains are suitable for operating temperatures from -20 ° C to 100 ° C.

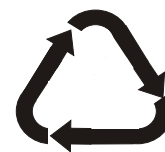

Listed properties are guide values and may be used as knowledge base. The ekd material specifications may differ from this values and are under reservation of necessary technical changes.

Property (standard)	Test condition	Value		Unit
		d.a.m.	conditioned	
Mechanical properties				
Yield stress (ISO 527)	5 mm/min	170	120	MPa
Yield strain (ISO 527)	5 mm/min	3,0	7,0	%
Tensile modulus (ISO 527)	1 mm/min	10000	7000	MPa
Charpy impact strength (ISO 179u)	23 °C	100	110	kJ/mm ²
Charpy impact strength (ISO 179u)	-30 °C	85	85	kJ/mm ²
Flexural modulus (ISO178)	2 mm/min	9000	5500	MPa
Flexural strain at flexural strength (ISO 178)	2 mm/min	4,0	6,0	%
Thermal properties				
Melting temperature (ISO 11357-1, -3)	10 °C/min	213		°C
Temperature of deflection (ISO 75-1, -2)	1,8 MPa	ca. 200		°C
Coeff. of linear therm. exp., paralle (ISO 11359)	23 to 55°C	0,2		10 ⁻⁴ /K
Coeff. of linear therm. exp., transv. (ISO 11359)	23 to 55°C	0,9		10 ⁻⁴ /K
Thermal conductivity (ISO 8302)	23°C	0,3		W/(mK)
Burning behavior (UL 94)	1,6 mm	HB		-
Electrical properties				
Relative permittivity (IEC 60250)	100 Hz	4,0	10	-
Relative permittivity (IEC 60250)	1 Hz	4,0	5,0	-
Volume resistivity (IEC 60093)		1E13	1E10	Ohm m
Surface resistivity (IEC 60093)		1E14	1E12	Ohm
Other properties (23°C)				
Water absorption (saturation value)	water at 23°C	ca. 6,5		%
Water absorption (equilibrium value)	23°C, 50% r.h.	ca. 1,8		%
Density (ISO1183)		1400		kg/m ³
Glass fibre content (ISO 3451)		35		%

MATERIAL DATA SHEET

PA 66 (HIGH IMPACT)

Listed properties are guide values and may be used as knowledge base. The ekd material specifications may differ from this values and are under reservation of necessary technical changes.

Property	(standard)	Test condition	Value		Unit
			d.a.m.	conditioned	
Mechanical properties					
Yield stress	(ISO 527)	5 mm/min	60	40	MPa
Yield strain	(ISO 527)	5 mm/min	8,0	12,0	%
Tensile modulus	(ISO 527)	1 mm/min	2100	1100	MPa
Charpy imp. strength (notched)	(ISO 179/1eA)	23 °C	18	100	kJ/mm ²
Charpy impact strength	(ISO 179/1eU)	23 °C	n.b.	n.b.	kJ/mm ²
Flexural modulus	(ISO178)	2 mm/min	2000	1000	MPa
Flexural strain at flexural strength	(ISO 178)	2 mm/min	80	40	%
Thermal properties					
Melting temperature	(ISO 11357-1, -3)	10 °C/min	258		°C
Temperature of deflection	(ISO 75-1, -2)	1.8 MPa	ca. 80		°C
Coeff. of linear therm. exp., transv.	(ISO 11359)	23° bis 85°C	0,7		10 ⁻⁴ /K
Thermal conductivity	(ISO 8302)	23 °C	k.A.		W/(mK)
Burning behavior	(UL 94)	1,6mm	HB		-
Electrical properties					
Volume resistivity	(IEC 60093)		1E17	1E14	Ohm m
Surface resistivity	(IEC 60093)		2E13	2E12	Ohm
Other properties (23°C)					
Water absorption		24h,23°C	ca. 0,75		%
Density	(ISO1183)		1080		kg/m ³
Glass fibre content	(ISO 3451)		0		%

The following list of substances and compounds are reference values for the resistance of polyamides. Polyamides are generally resistant to aliphatic and aromatic hydrocarbons (eg, fuel), fats and oils and to many organic solvents. Polyamides are not resistant to organic and inorganic acids, some even in low concentrations, as well as to strong oxidizing agents. Fittings made of polyamide are generally regarded as stress crack resistance.

resistant

acetone	acetylene	allyl alcohol	ammonia	ammonium nitrate
ammonium sulfate	benzene	beer	bio gasoil	bitumen
brake fluids	bromo	butane	butanol	camphor oil
chloramines	chlorobenzene	citric	citrus	cyclohexanol
dibutylphtalat	gasoil	dibutyl ether	dimethylamine	dioxane
ferricIII chloride (neut.)	petroleum	ether gas	ethane	ether
ethyl acetate	ethylene	ethylene oxide	CFC	fatty alcohols
fats, waxes	fish oils	fixing baths	photo developer	fruit juices
furfural	gelatin	gear oil	glycerol	urea (20%)
heating oil	heptane	hexan	hexachlorobenzene	isocyanate
potassium carbonate	potassium chloride (10%)	isopropanol	isooctane	ketones
co2	carbon fuels (gasoline)	copper sulfate	linseed oil	
seawater	methane	lactic	mineral oils	
sodium carbonate	sodium chloride	sodium sulfide		phosphates
sodium hydroxide (10%)	paraffin oil	petroleum ether	lamp oil	
phosphoric acid (30%)	rapeseed oil	propane	carbon disulphide	soda solution
hydrogen sulphide	welding solution (pH 9.5)	silver nitrate(10%)	silicone	
nitrogen	styrene	tallow (beef fat)	turpentine	urine
carbon tetrachloride	tetrafluoromethane	ink	toluene	
tartaric acid	xylene	benzene hydrogen	sugar solution	

conditionally stable

acetaldehyde	aniline	benzyl alcohol	chloroform	vapor
diethylene glycol	dimethyl formamide	dimethylsuloxid	ferric III chloride, acidic, watery	
acetic acid (5%)	ethanol, conc.	ethylene glycol	formaldehyde (10%)	formamide
glycol	hydraulic fluids	potassium dichromate	potassium hydroxide, conc.	
methyl alcohol	oxalic acid (10%)	phosphoric acid (10%)	sulfur dioxide dry	propanol
sulfuric acid	vinyl chloride	triethanolamine	trichlorethylene vapor	
tin chloride (aqueous)				

unstable

acrylic acid	formic acid (10%)	benzaldehyde	bromide	butyric acid (conc.)
calcium hypochlorite	chloramines	chlorine	hydrochloric	acetic acid (30%)
hydrofluoric	hydrofluoric acid (40%)	iodine	iodide	perchlorate (2%)
potassium	permanganate (10%)	solder liquid	sodium hypochlorite	20 ppm of ozone
nitric acid	perchloric acid (1%)	hydrochloric acid (1%)	oxygen	sulfuric acid(10%)
thionyl chloride	trichloroacetic	trichloroethyl hydrogen peroxide (10%)		cinnamaldehyde
Zinc halides (aqueous)				

soluble

formic acid (85%)	calcium chloride	aniline	alcohol. Chloral hydrate	
dimethylformamide	ethylene glycol	dimethyl	phenol	cresols
hydrochloric acid conc.	sulfuric acid (96%)			

About this catalogue

Descriptions and technical informations which are shown in this catalog are purely informative and provide only the general information. An assurance of properties for certain applications is denied. The catalog reflects the technical state of the art at the time of the edition. Changes to the products remain at any time. The in the order and contract agreed properties of the product is binding.

All copyrights of all texts and illustrations in this catalog are ekd-gelenkrohr GmbH owned. Copies of whatever kind and disclosure to third parties requires the express consent of ekd-gelenkrohr GmbH.

General operating and safety instructions

Energy chains are technical products, which are constructed as part of an engineering-design for concrete applications according to the state of the art. In dealing with these products the compliance to the operating and safety instructions and general rules of technology is assumed.

Thus, for example, the stay in the work area of an energy chain is only allowed if adequate safeguards are in place to prevent accidental moving of the chain. The accident prevention regulations are strictly to be observed. Further requirements, such as when operating in explosive hazardous areas are - if applicable - to take into account as well.

The intended use has to be in compliance with the design limits of energy chains. The below known from practical experience can lead to considerable functional errors or damage of the energy chain:

- improper handling of the energy chain during transport and assembly
- undue weight load of the energy chain, especially of a free carrying upper strand of the chain
- operating the energy chain out of the limits of the designed travel distance
- introduction of interference contours, components or parts thereof into the operating area
- improper line load

Are the operating conditions such as wear-boundary conditions of abrasive dust entry or plant-vibration and oscillations can not be avoided, so by appropriate constructive steps and inspection intervals, particularly in unsupervised, automated operating systems, unforeseen equipment failures have to be avoided.

energy chains
lines
accessories



energy guiding
systems



complete
systems

ekd gelenkrohr GmbH
Steinhof 47
D-40699 Erkrath
phone +49 211 24 90 40
fax +49 211 24 10 88
e-mail ekd-gelenkrohr@t-online.de
www.ekd-gelenkrohr.de