



Building Automation

Overview





Contents

WAGO Automation	4
WAGO Building Solutions	6
Integrated Building Automation	7
Universal, Compact, Economical – WAGO I/O System	8
WAGO I/O System 750/753	10
Basic Software	12
Libraries	14
Macro for Flexible Room Automation	15
Modules for Distribution Boxes	16
flexROOM®	18
WAGO Lighting Management	20
KNX	22
BACnet	23
DALI-2	24
MODBUS/TCP/IP	26
Cybersecurity Directly in the Switch	27
SMI Master	28
EnOcean Radio Technology	28
M-Bus Master	29
MP-Bus Connection	29
Touch Panels 600	30
Additional Technologies	31

WAGO Automation

WAGO's *ELECTRICAL INTERCONNECTIONS* division has undergone rapid development over the years, paving the way for more industry-leading innovations. In 1995, WAGO reached an industry-changing milestone by launching the WAGO I/O System, the world's first fieldbus-independent I/O system with fine-grained modularity. The introduction of this industrial fieldbus systems has significantly impacted automation. Modern, decentralized topologies with distributed "intelligence" have replaced traditional, centralized automation structures. Now, WAGO is meeting virtually all of the industry's needs as both the leader in

Spring Pressure Connection Technology and a pioneer in automation technology. For more than 15 years, WAGO has successfully offered a wide range of advanced building automation components based on the WAGO I/O System 750. The WAGO I/O System 750's modular design enables project solutions to be easily and efficiently implemented. A wide range of controllers with open fieldbus protocols (e.g., M-Bus, BACnet, KNX, Modbus®) in combination with standard inputs/outputs or subsystems (e.g., DALI, SMI, EnOcean, LonWorks®) covers the entire building automation market.

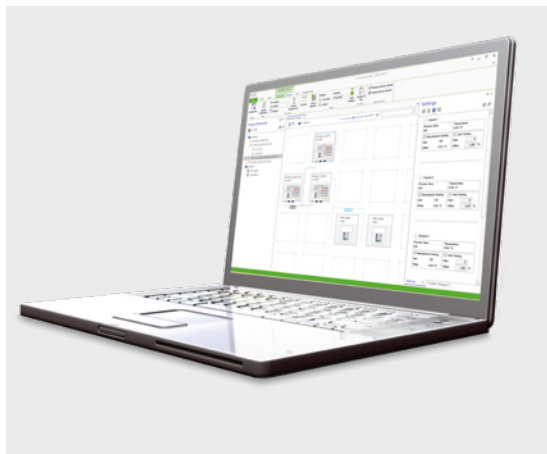

Engineering Software

WAGO's **e!COCKPIT** Automation Software expedites operational system startup, while reducing development time for automation projects! Ensuring a project's long-term viability through sustainable cost savings hinges on a user's ability to quickly adapt to new software that offers a high degree of reusability. **e!COCKPIT** is an integrated development environment that supports every automation task, from hardware configuration, programming and simulation to visualization.



Operation and Monitoring

WAGO's high-performance Touch Panels for demanding control and visualization tasks improve the operability of machines and systems, while offering an outstanding design and advanced technology.

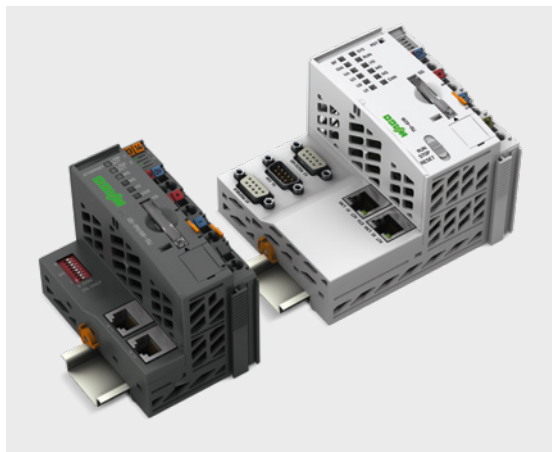

Controllers

WAGO's family of high-performance programmable controllers boasts a wide range of capabilities for controlling any automation task in both centralized and decentralized applications. For decentralized control tasks, WAGO's controllers can be incorporated into the most prevalent fieldbus networks and they record all field

signals via I/O modules. WAGO's IEC 61131-3 programmable controllers perform a variety of automation tasks, while providing all the benefits of proven PLC technology (e.g., strength, stability, reliability and near-high constant uptime).

I/O Systems

The broad portfolio enables flexible, cellar-to-ceiling solutions with conventional I/O modules, standardized industry-specific fieldbus protocols and subsystems (DALI, KNX, DMX) for typical applications in lighting, shading, HVAC and more. A comprehensive selection of accessories completes the portfolio (e.g., RJ-45 plugs and RS-485 interfaces).



Industrial Switches and Wireless Technology

In building automation and industrial automation, industrial switches enable communication within industrial ETHERNET systems. These are complemented by economical industrial managed switches, which reliably transmit data traffic securely, thanks to encryption technology and authentication. They also protect against network failures, increasing system availability. *Bluetooth*[®] and WLAN gateways allow mobile devices to be integrated into the network.

WAGO Building Solutions

For Specific Markets



Office and Administrative Buildings

Investors are increasingly placing a great amount of importance on the flexible use of space that's supported by an appropriate infrastructure. WAGO's room automation systems can be commissioned quickly and flexibly adapted to address this need. Efficiency class A per DIN EN 15232 can be easily and reliably achieved using WAGO products.



Production Facilities and Warehouses

Safe and efficient energy management in production facilities and warehouses is essential for reducing operating costs. Lighting significantly contributes to overall operating costs. Using WAGO's solutions, energy costs can be significantly reduced.



Retail Centers

Building operation is becoming more and more expensive – a key reason why operators are searching for new building automation solutions. Intelligent buildings provide a secure and comfortable environment, while keeping costs under tight control. WAGO's building automation systems can readily help operators meet specific energy costs to improve the bottom line.



Public Infrastructure Buildings

Visitor safety, comfort and convenience are of primary importance in operating airports, convention centers and railway stations. WAGO's integrated building automation solutions meet the high efficiency and safety standards for public infrastructure buildings.

Integrated Building Automation – Greater Energy Efficiency



Lighting

The ideal lighting control system not only creates an atmosphere that promotes a sense of well-being, but also supports energy-efficient room and building lighting. WAGO's lighting control solutions skillfully set up lighting scenes – from simple switching and dimming, to tailored and daylight-dependent lighting controls. Even sophisticated control tasks such as “Human Centric Lighting” (HCL), as well as impressive and artistic lighting of buildings, can be easily implemented using WAGO products. “WAGO Lighting Management” is an application solution that offers quick and easy commissioning, as well as efficient building operation.

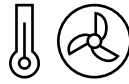

HVAC

Heating, ventilation and air conditioning (HVAC) systems represent one of a building's major costs. Automatically regulating HVAC systems minimizes energy costs and improves the climate in a building. Planning and executing HVAC systems requires extensive knowledge from every building automation professional – from the creation of sophisticated control programs to visualizing energy flows. Extensive libraries with ready-made system macros from WAGO significantly simplify all of this programming. The use of these system macros contributes to standardization, significantly reducing costs.



Room Automation

Planning, implementation and building operation must demonstrate maximum efficiency and a high degree of adaptability. Modern building technology maximizes flexibility by enabling rooms to be individually planned, managed and even repurposed at any time – without any programming. WAGO's state-of-the-art room automation solutions perform many tasks in a building: They optimize room temperature, position sunblinds based on the sun's arc throughout the day, regulate light intensity and switch lights off when not needed.



Energy Efficiency

Energy efficiency hinges on sensibly planning a building's technical systems. Constructing or retrofitting buildings is an operational challenge in terms of energy savings. Investors want to see a high level of energy efficiency in their buildings. Compliant with the European Union's energy efficiency class A, WAGO's building automation solutions can help reassure investors that the building's operational life-cycle costs will be minimal.

Universal, Compact, Economical – WAGO I/O System

Management

The automation stations are connected to the building management system on the management level. Standardized protocols facilitate simple data exchange.

It's all about data: Thanks to modern information technology, the most important information from building automation is no longer restricted to the local building management, but is now available at any time and place. However, the technical conditions must be right for this. WAGO's PFC Controllers are equipped with cloud connectivity so they can transfer data to the WAGO Cloud – or to any other MQTT broker.

Automation

Automation stations control and regulate operational systems. ETHERNET has long since established itself as the dominant transmission medium in the automation area. As such, WAGO's automation stations can be easily and efficiently interlinked using open, standardized bus protocols for building automation (e.g., BACnet IP, KNX IP or Modbus/TCP). I/O modules and fieldbus interfaces permit connection of nearly any sensor or actuator from the field.

Field

Flexible, easy-to-install media are required on the field level. This is why WAGO offers a wide variety of solutions: From products for directly connecting standard sensors and actuators via I/O modules, to diverse fieldbus interfaces for two-wire subsystems (e.g., Modbus RTU, MP-Bus, M-Bus, BACnet MS/TP, KNX TP1 or LonWorks®), to connection with radio systems like EnOcean.

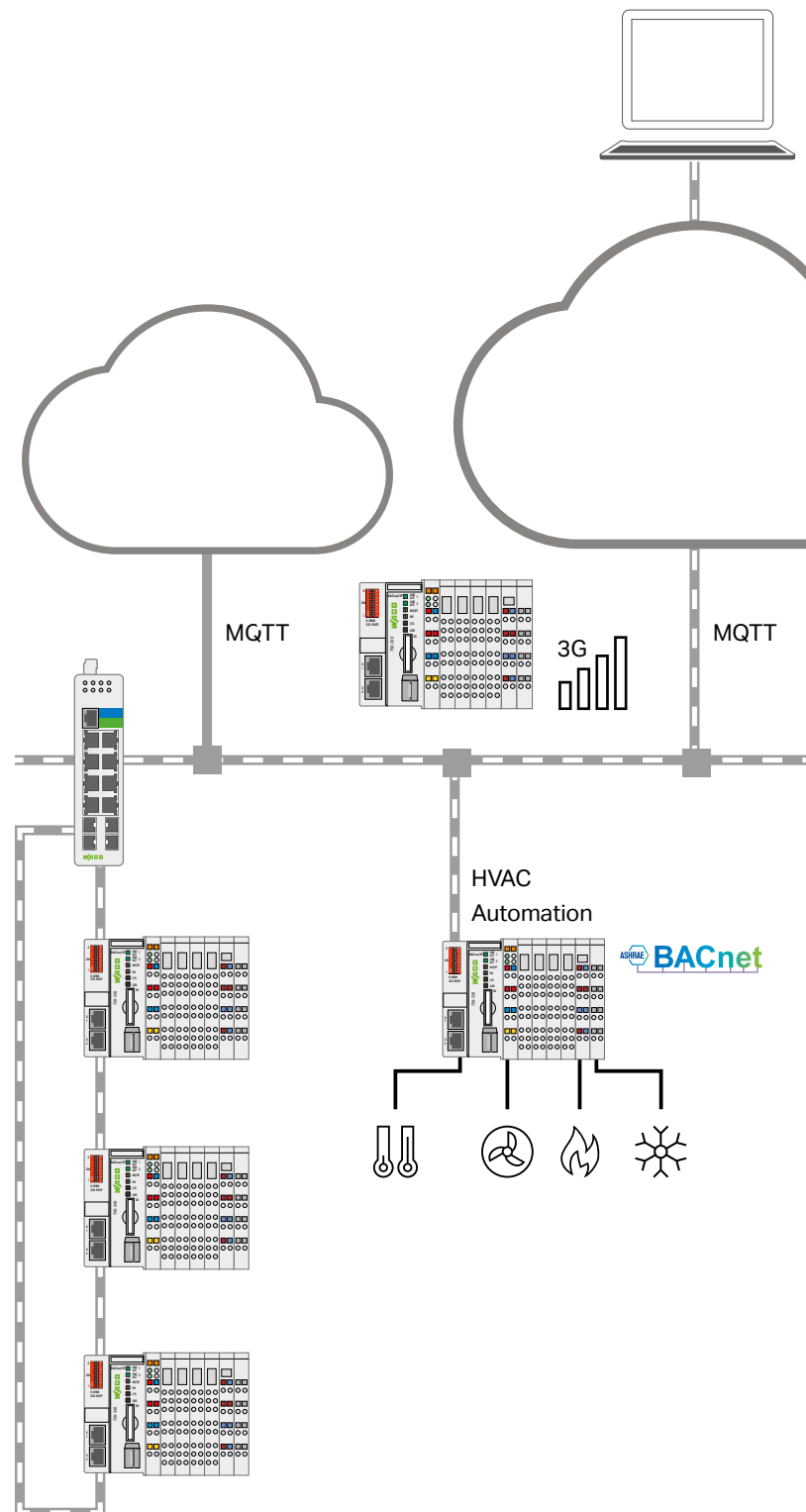

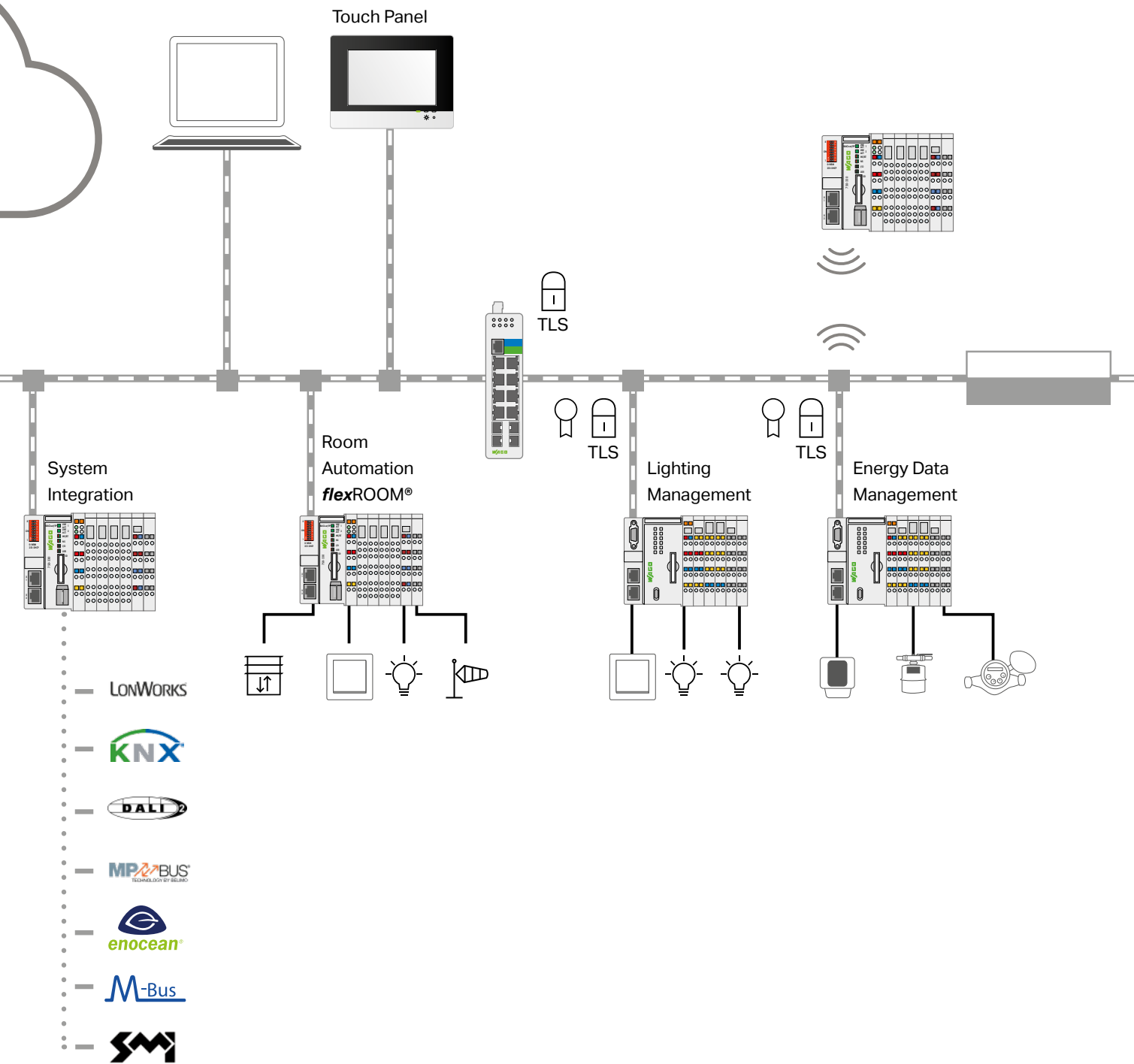



WAGO I/O System 750/753

Automation Stations and I/O Modules

WAGO's comprehensive range of fieldbus controllers supports established protocol standards. Special versions, e.g. for the BACnet/IP and KNX IP bus systems, are optimized for building automation. The diverse product range of I/O modules allows integration of external systems such as lighting control (DALI), sun protection (SMI), wireless switches (EnOcean) and much more. more.

BACnet Controllers

For BACnet communication, WAGO offers two different controllers equipped with BACnet/IP (ETHERNET) or BACnet MS/TP (RS-485) interfaces. Both controller variants support the BACnet Building Controller (B-BC) profile and are freely programmable. The controllers can be easily commissioned with WAGO's user-friendly BACnet Configurator.

KNX IP Controller

The KNX IP fieldbus controller is freely programmable and communicates via a standard 10/100 Mbit ETHERNET network. The KNX interface is commissioned using the ETS Network Management Tool. A product database from WAGO is available for commissioning the controller.

ETHERNET Controllers

WAGO provides a wide range of ETHERNET controllers in different performance classes and with various interface combinations. The ETHERNET fieldbus controllers support a wide variety of standard ETHERNET protocols for easy integration into IT environments (e.g., HTTP, BootP, DHCP, DNS, SNTP, SNMP, FTP).

PFC Controllers

WAGO's PFC Controllers are ideal for more complex control applications and the higher-level control of series machines. The PFC200 Controller offers numerous interfaces.

Modbus® Controllers

The Modbus® protocol is a communication protocol based on master/slave or client/server architecture. The primary purpose of the protocol is facilitating reliable, fast communication between automation and field devices.



Analog Input Modules

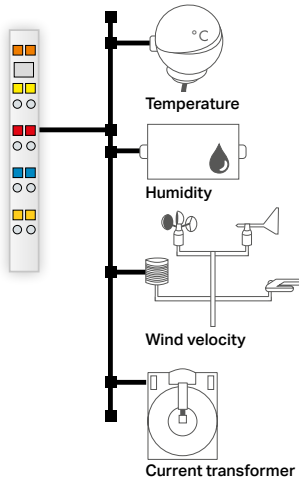

Analog Output Modules

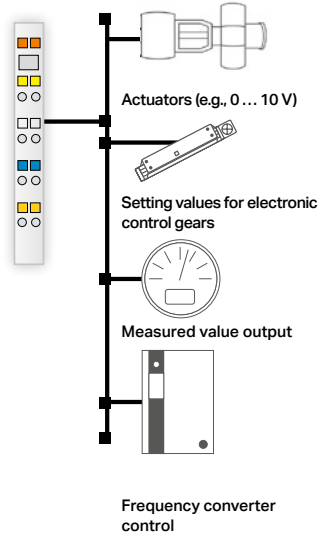

Digital Input Modules

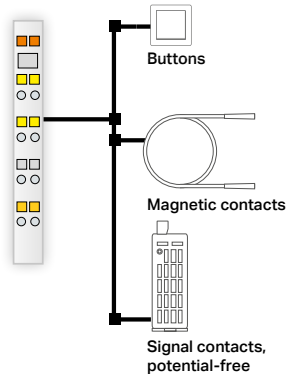

Digital Output Modules

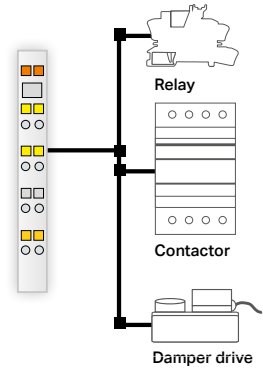

Communication Modules

RS-232 C/RS-485

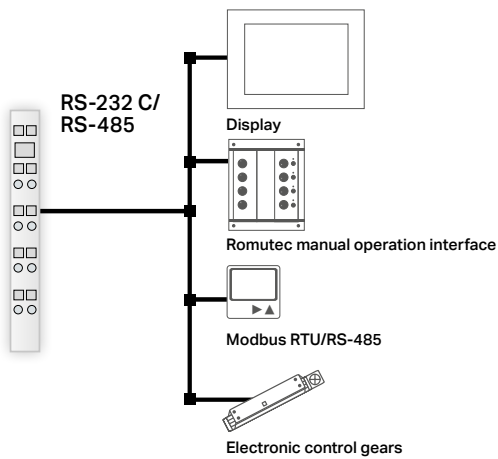

Specialty Modules



3-Phase Power Measurement Modules

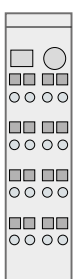

Basic Software

Programming and Configuring with e!COCKPIT

WAGO's **e!COCKPIT** Automation Software expedites operational system startup, while reducing development time for automation projects! Ensuring a project's long-term viability through sustainable cost savings hinges on a user's ability to quickly adapt to new software that offers a high degree of reusability. **e!COCKPIT** is an integrated development environment that supports every automation task, from hardware configuration and programming, to simulation and visualization, to commissioning – an all-in-one software package.

Your Benefits:

- Integration of new devices like Touch Panels and second-generation PFCs
- A smart design
- Graphical network configuration
- Extensive libraries with ready-made system macros

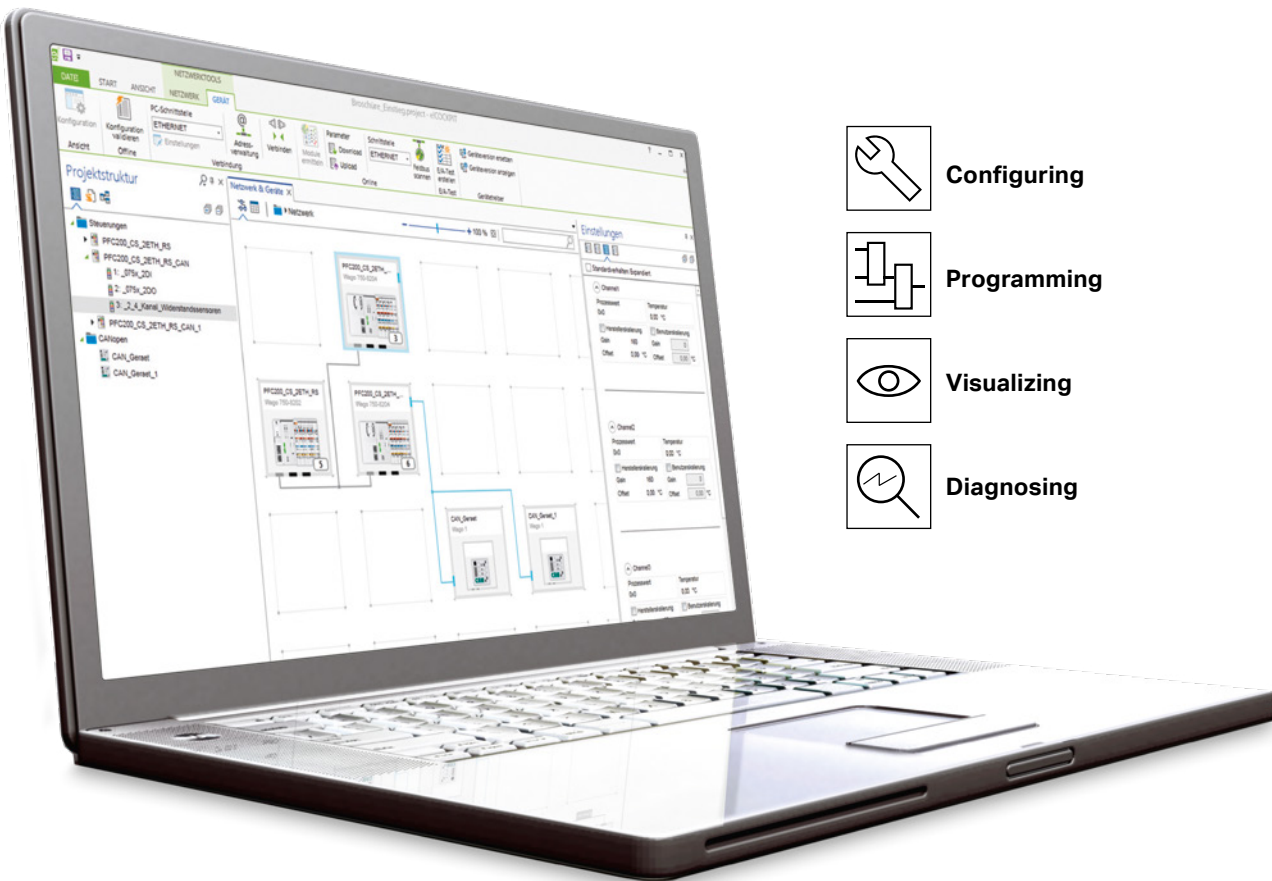

Configuring



Programming



Visualizing



Diagnosing

Communication in the BACnet and Modbus® Network

WAGO offers software tools specifically engineered for select technologies, applications and products. Among these are WAGO's BACnet and Modbus® Configurators, which allow devices connected to a specific network to be easily and efficiently addressed and parameterized.

The Modbus® Configurator is integrated into **e!COCKPIT**; the BACnet Configurator is an extension application for the **e!COCKPIT** pro-

gramming environment. Both configurators are used directly in the programming environment for quickly integrating the WAGO Controllers into the corresponding networks.

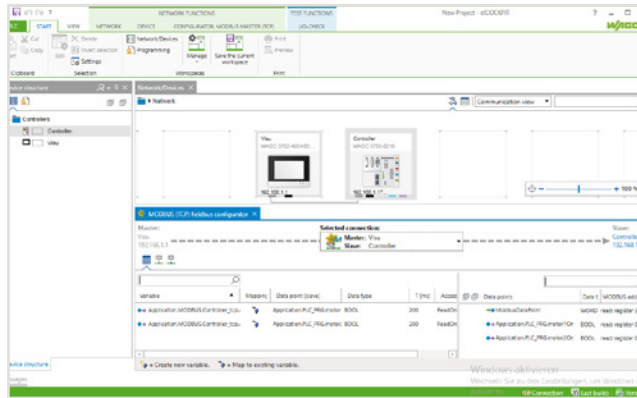
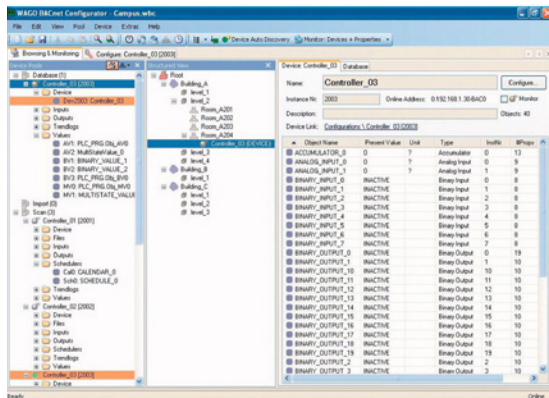

WAGO-I/O-CHECK in e!COCKPIT

As a component of **e!COCKPIT**, **WAGO-I/O-CHECK** is an easy-to-use Windows application for operating and displaying a WAGO I/O System 750's Controller without the node being connected to a fieldbus system. The software reads the configuration from the node and displays it graphically on the screen. This graphic can be printed together with a configuration list as documentation. With **WAGO-I/O-CHECK**, it is possible to display and specify the process data of the I/O modules. The field wiring, including all sensors and actuators, can thus be checked before startup.

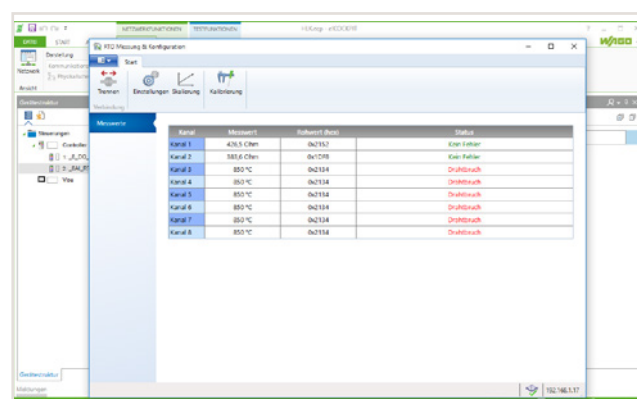
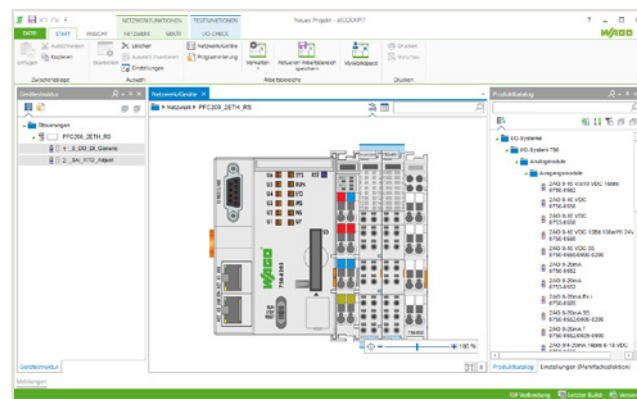



Libraries

Building Automation

To simplify programming, WAGO has a multitude of pre-configured functions available for free: from simple room applications (such as lighting, dimming and anti-glare control), to HVAC modules, system macros and communication applications. The latter offer interfaces to KNX, DALI, EnOcean and MP-Bus, while enabling emails and SMS messages to be sent. The libraries can be directly used to efficiently create customer applications. Libraries for the following applications are available:

Room Automation

- Lighting
- Sun protection
- Room temperature control

System Automation (HVAC)

- Error message monitoring
- Frost protection monitoring
- Heat recovery
- Room/air intake temperature cascade control
- Heating circuit control
- Boiler sequence control

Communication

- KNX
- EnOcean
- DALI
- DMX
- SMI
- MP-Bus
- M-Bus
- SMS/email
- Cloud (e.g., MQTT)

Application Notes

For complex building automation challenges, examples and documents are available that describe applications in their entirety.

Macro for Flexible Room Automation

The “WAGO Room Automation” macro is a library, including a base application, for easily creating scalable room automation solutions with **e!COCKPIT**. It is based on WAGO’s proven **flexROOM**® solution, which flexibly adapts to project-specific requirements thanks to its scalability. All the relevant room functions of the building systems for lighting, shading and room climate control have been set up and can be customized or expanded as needed.

It also offers a Web-based graphical user interface that can be used to integrate and configure lights, sunblinds, actuators, sensors and room control units. The concept is based on segments as the smallest functional units in buildings; room automation functions are performed in these across all building systems. This segment-oriented concept allows a flexible association of office space with rooms or open-space areas throughout the entire lifecycle of the building.

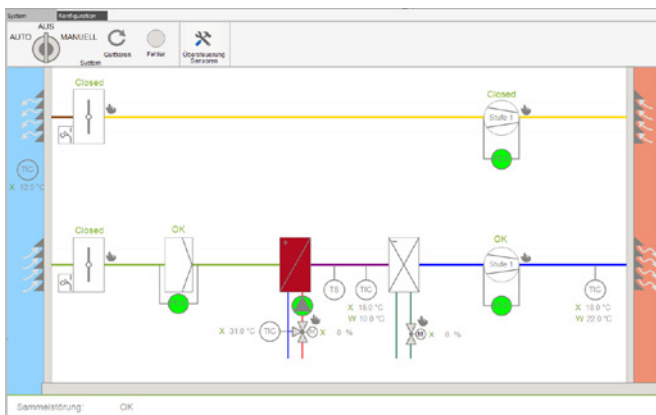

Macros for ventilation, boiler, heating circuit and duty cycle monitoring (hot water), including ready-to-use configuration screens in the Web visualization

WAGO provides comprehensive templates, which include ready-made system macros for many common applications. This time-saving convenience minimizes HVAC configuration for users. After rapidly configuring the application – via simple data point and system parameter assignment – users can directly commission the completed application.

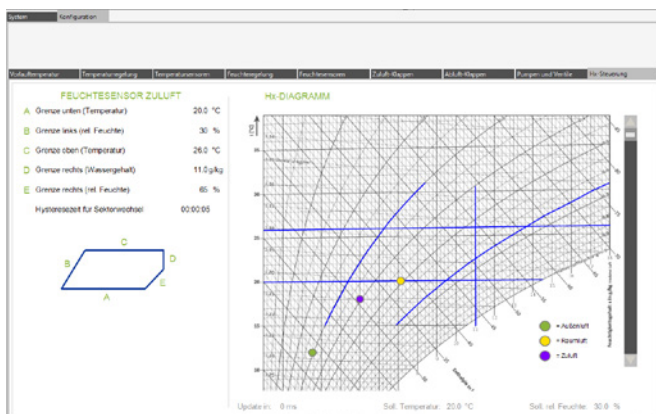

Modules for Distribution Boxes

The products and solutions outlined in this brochure create a solid foundation for building automation. However, additional peripheral systems, control modules and components are required for complete automation solutions.

WAGO not only provides a wide range of products, but can also furnish tailor-made solutions consisting of fully equipped system distribution boxes. Users benefit not only from shortened assembly times and error-free installation, but also from easier commissioning.

Key Components at a Glance:

- **Power Supplies**
24 V power supply for WAGO Controllers
- **Network Infrastructure Components**
From a simple switch to configurable communication capabilities with a fiber optic connection
- **Customizable ETHERNET**
User-configurable ETHERNET RJ-45 connectors
- **Interface Modules**
For RJ-45 patch cables and universal connections, such as a 9-pole Sub-D RS-232 connection

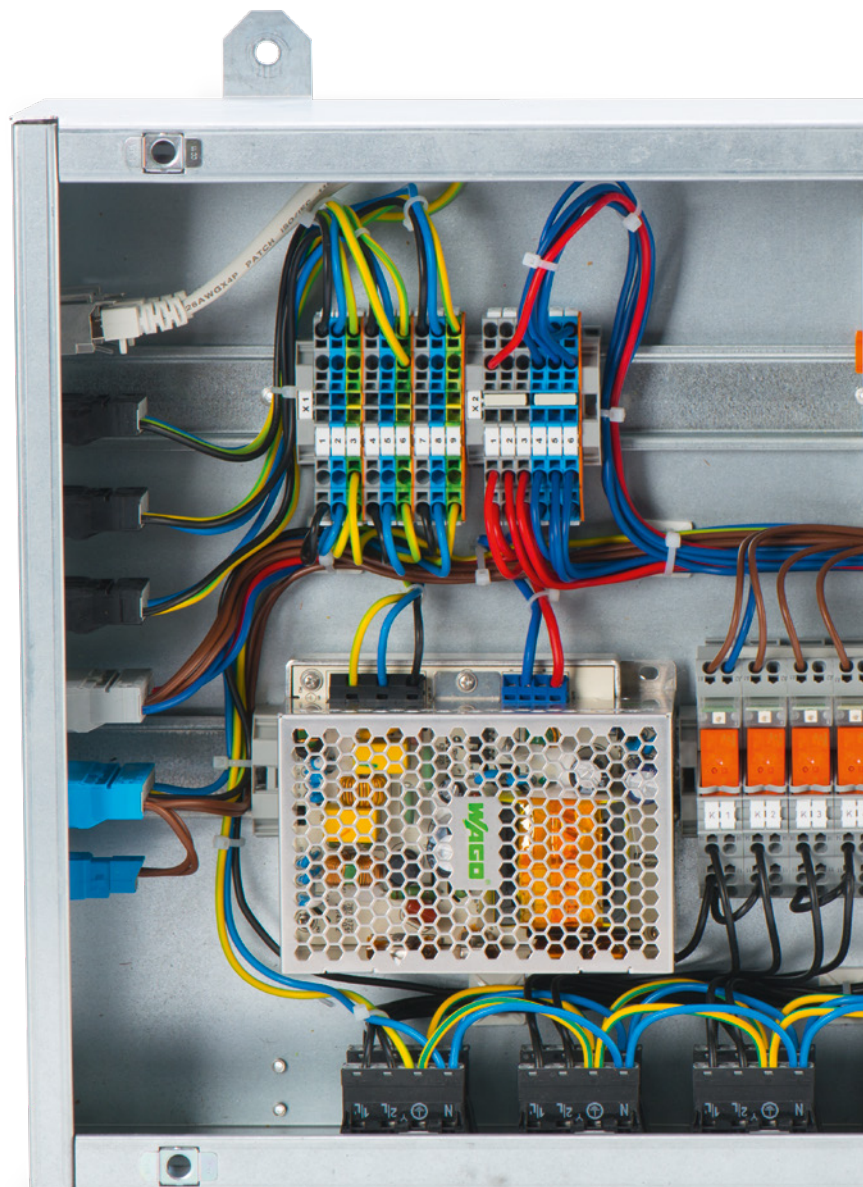

- **Relays**

To control loads, such as lights and shutter drives more. more.

- **WINSTA® Pluggable Connectors**

Innovative connectors from the WAGO WINSTA® line for pre-assembled components ensure fast and safe on-site installation; they accommodate conductor cross-sections up to 4 mm² (12 AWG) and nominal currents up to 25 A.

- **Screwless Rail-Mount Terminal Blocks**

WAGO TOPJOB® S is a range of screwless rail-mount terminal blocks for building installations with conductors rated 1.5–16 mm² (16–6 AWG).

- **Current Measurement**

Coupled with electronic interface devices and the WAGO I/O System 750, WAGO offers a comprehensive range of perfectly tuned energy efficiency solutions.

- **WAGO I/O System**

Benefits of WAGO's successful fieldbus system: a solution with scalable performance, high integration density and an unbeatable price/performance ratio

- **Pre-Assembled Custom Solutions**

WAGO's product specialists have the experience and efficient solutions to assist you from initial specs to final install.

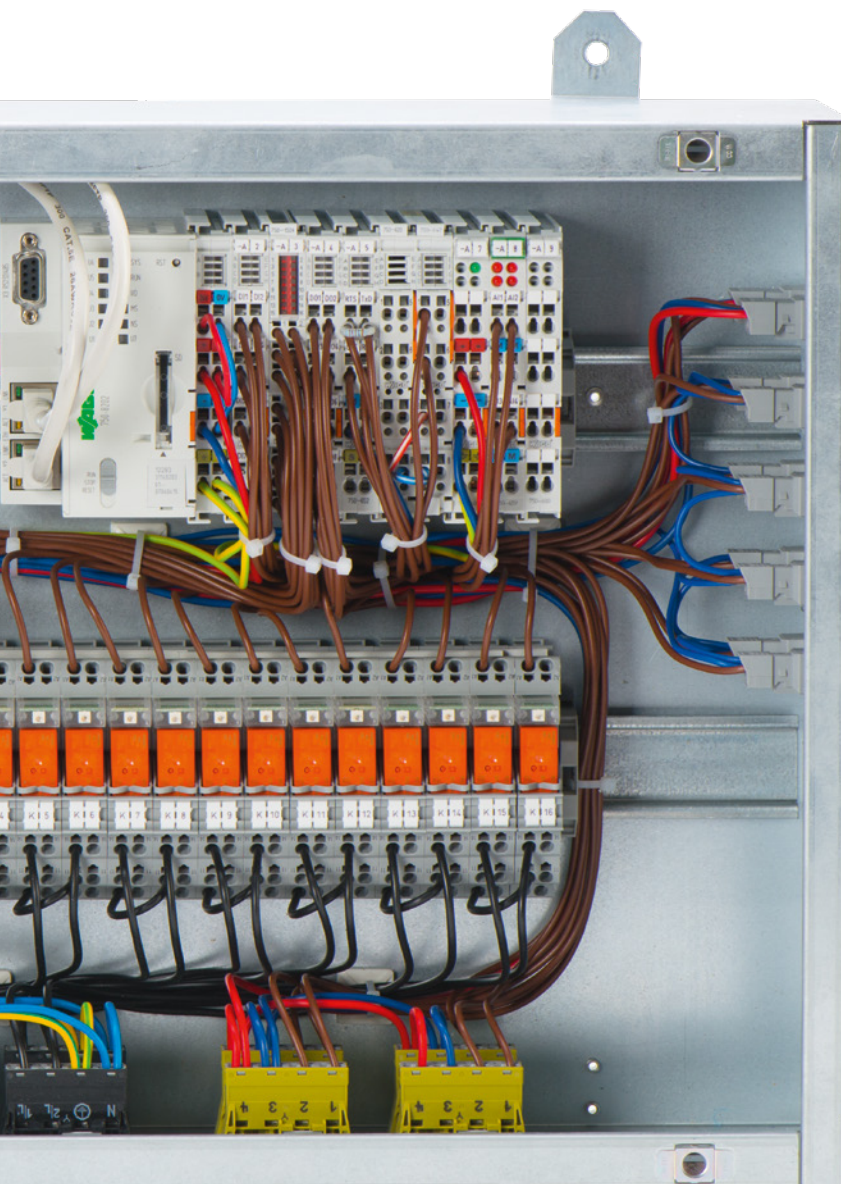



flexROOM®

A Flexible Room Solution

Our Solution

Planning, commissioning and building operation must demonstrate maximum efficiency and a high degree of adaptability. Pre-configured programs and pre-defined hardware significantly streamline planning and commissioning. The more applications created within a project, the greater the benefit. Flexible building operation (e.g., conversions and room remodeling) via special maintenance levels eliminates external service costs because the user can make their own changes.

Install, commission and configure according to project specifications – WAGO **flexROOM®** combines these strengths into a standard module. The integrated control unit and application software are precisely tailored to room requirements.

Parameter Setting

For each room, parameters can be individually stored for lighting, shading and room control. All parameters are cyclically saved either directly in the distribution box or on a separate computer via network connection. A higher-level management station accesses the distribution box parameters via the open Modbus TCP/IP protocol. This ensures that all modifications can be implemented on site or via the management station. BACnet or KNX IP systems can also be connected via Modbus TCP/IP.

Configuring – Not Programming

Each WAGO **flexROOM®** Distribution Box has a Web interface. Both the commissioning technician and end user can configure the controls for each room via Web browser, regardless of the user's location and the distribution box in use. Complete wall relocations, room assignments, lighting and shading groups can be changed from the parameter interface. No additional software is required.



Advantages of **flexROOM®** as a Distribution Box Variant

The distribution boxes are delivered ready to operate and can be installed directly in a suspended ceiling or a sub-floor. Room segment configuration is performed directly in the distribution box via standard Web browser. Installation is quick and easy thanks to **WINSTA®** pluggable connection technology. Several **flexROOM®** Distribution Boxes can be wired into a building automation network via **ETHERNET** to automate a building area, a floor or an entire office section. A standard Web browser also establishes communication between the distribution boxes. If electrical distribution boxes are present, **flexROOM®** components can also be installed or retrofitted during facility renovation. **flexROOM®** reduces space conversion costs because expenses are transparent and predictable.

The screenshot shows a control interface with the following sections:

- DATEI**: A menu icon.
- RAUME**: A light bulb icon, a light switch icon, and a temperature gauge icon.
- SCHNELLREICHWECHSEL**: A dropdown menu with options: "Zentral Licht", "Zentral Jalousie", and "Zentral Party".
- MELDUNGEN**: A "Manuell" checkbox and a numerical input field containing "24714E".
- Achse 1-8**: A grid of controls for eight axes. Each axis has a "Kommentar" field, a light bulb icon, a "Szenen" dropdown menu, and a temperature gauge.
- EnOcean ID1**: A dropdown menu with "EnOcean ID1" and "EnOcean ID2" options.
- Zeitschaltkanal**: A dropdown menu with "aktuelles Set" and "Set" options.
- Set**: A dropdown menu with "Set 1" and "Set 2" options.
- Zeit für**: A dropdown menu with "Zeit aktuelles Set" and "Zeit aktuelles Set" options.

WAGO Lighting Management

The Intelligent Solution for Lighting Controllers

Modern lighting management offers more than a mere reduction in energy consumption and costs – it unites economics and resource conservation with user comfort and flexibility.

Our Solution

WAGO Lighting Management is a proven solution based on predefined hardware and preconfigured software, which greatly simplifies planning, commissioning and operation. The basic idea: WAGO Lighting Management is based on the different lighting requirements in warehouses and production facilities. For example, a production facility is divided into virtual rooms in which the light can be easily adapted. Each virtual room receives signals from sensors and actuators in order to automatically set the appropriate light intensity. Virtual rooms allows both conversions and room remodeling to be implemented quickly and simply via Web configuration. Besides conventional inputs and outputs, the system also supports a wide variety of technology, such as DALI-2, EnOcean and KNX.

Configuration and Commissioning

WAGO Lighting Management features a Web interface that allows you to easily create and edit virtual rooms. Do you need to illuminate a production line, hallway or a storage area? No problem – simply create three different rooms with the required functions. Parameter values are stored on an SD card or a backup server via FTP. The values can be forwarded to a higher-level building control system or to a production control center via Modbus TCP/IP.

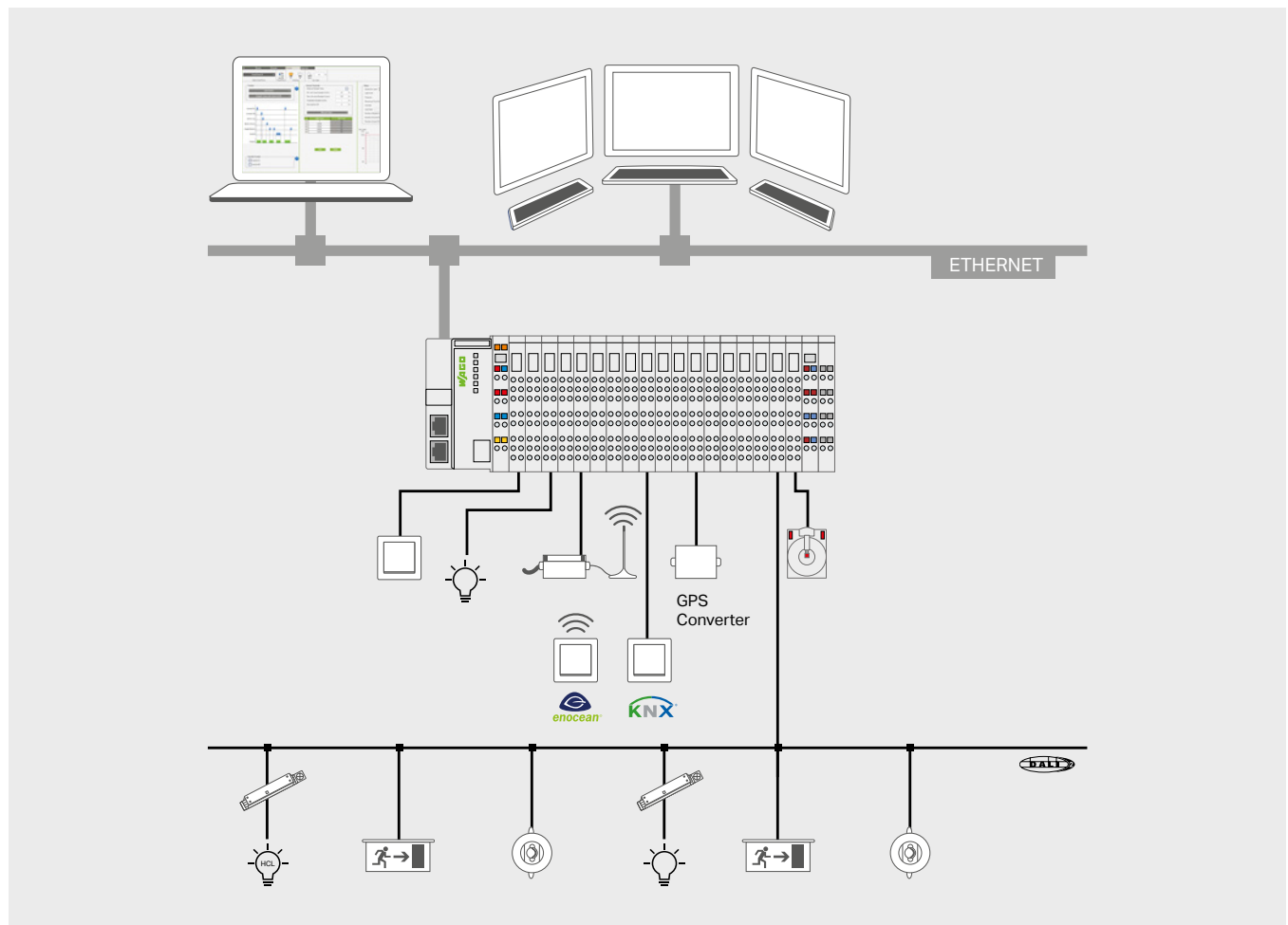

Operation

A state-of-the-art Web-based user interface is available for operation and visualization of status messages during ongoing operation. Lighting management is operated through a Web browser on a desktop computer, laptop, touch panel or mobile device, such as a tablet or smartphone.

The user interface can be set up and managed based on your individual needs. In addition to language and color settings, HMI devices, users, rooms and your own custom configuration profiles are available. The rooms in a building can be freely arranged and grouped into areas.

WAGO Lighting Management significantly reduces the overall costs of new installations and conversions. WAGO Lighting Management provides the perfect combination of high-quality hardware and intuitive custom software. Reduce lifecycle costs with quick and simple commissioning, comprehensive diagnostic and service capabilities and simple adaptation of the lighting situation to varying requirements.

Your Benefits:

- Reduce lifecycle costs through efficient lighting management
- Scalable to any system requirement
- Commissioning via self-guiding, wizard-based configuration
- Simple conversion without programming
- Connect to higher-level management and control systems within industrial or technical building environments
- Clear and convenient operation via mobile devices

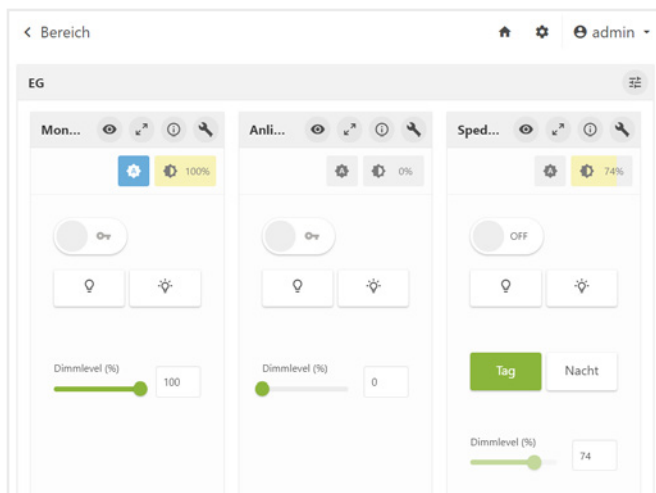
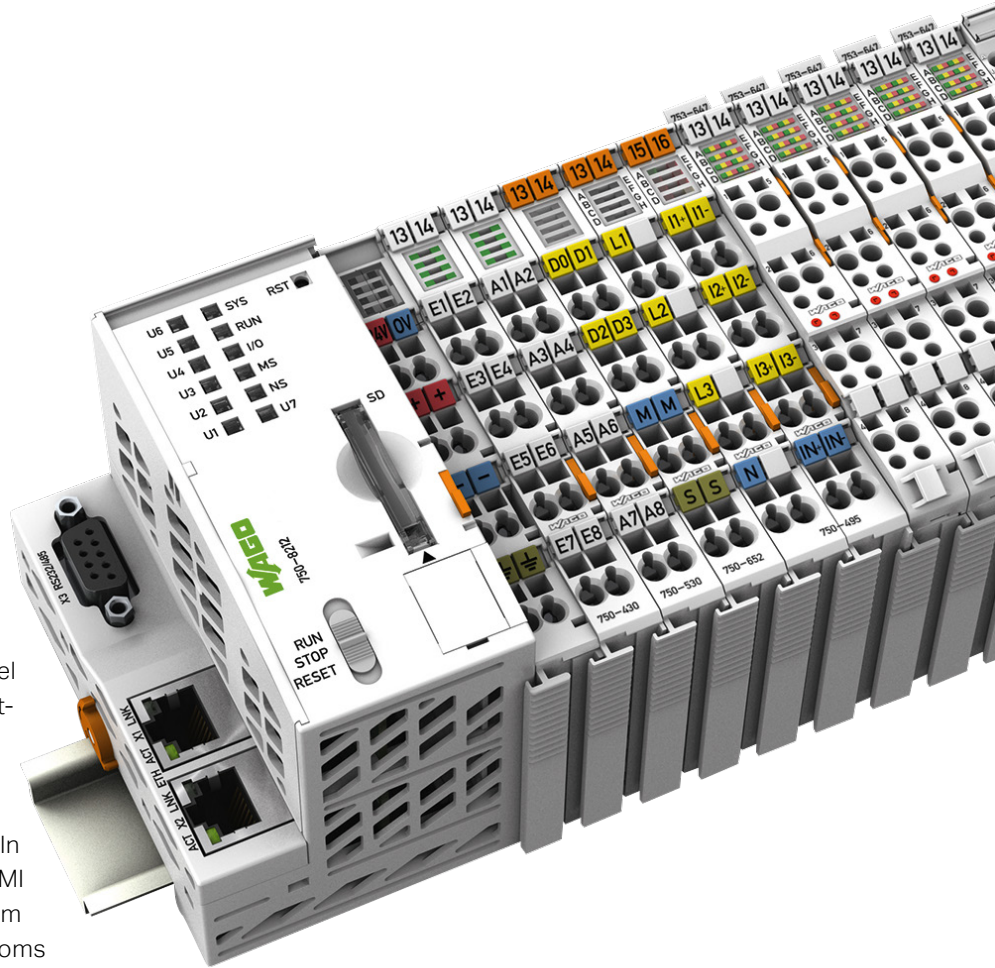

Do you need to illuminate a large area?
No problem! WAGO's lighting management application allows you to illuminate about 3000 m², depending on the type of lamp. For larger areas, it is easy to link a number of controllers with one another.

Maximum Flexibility and High Performance

KNX is a uniform, manufacturer-independent communication protocol for intelligently networking various building automation functions. KNX is used to plan and implement energy-efficient solutions, while incorporating greater functionality and convenience into buildings.

With its freely programmable **KNX IP Controller**, WAGO offers a product that links the KNX world with ETHERNET. Using this controller, you can link, control, regulate and monitor all types of KNX devices from a variety of building systems. When paired with the I/O modules from the WAGO I/O System 750, other sensors, actuators and sub-buses (e.g., DALI, EnOcean) can be easily integrated into the controller.

The **KNX TP1 Module** connects KNX TP1 networks to the WAGO I/O System and is compatible with all building-related WAGO Controllers (e.g., BACnet).

Combining a **KNX IP Controller** with a **KNX TP1 Module** creates a router that automatically connects the KNX two-wire bus system to ETHERNET. This provides a tremendous amount of freedom to conveniently operate buildings or systems via the Internet – wherever you are.

WAGO ETS Plug-In

The ETS standard programming tool assigns group addresses and commissions WAGO KNX products. WAGO's specially developed plug-in supports users in configuring the KNX interface.

Additional Benefits

WAGO's innovative KNX components are seamlessly integrated into the WAGO I/O System. This provides a wide range of input, output and specialty modules for sub-bus systems such as DALI, as well as controllers for higher-level networks such as BACnet. Cost-effective control units replace several individual KNX components as room and area controllers. The KNX standard provides communication with thousands of devices from other manufacturers.

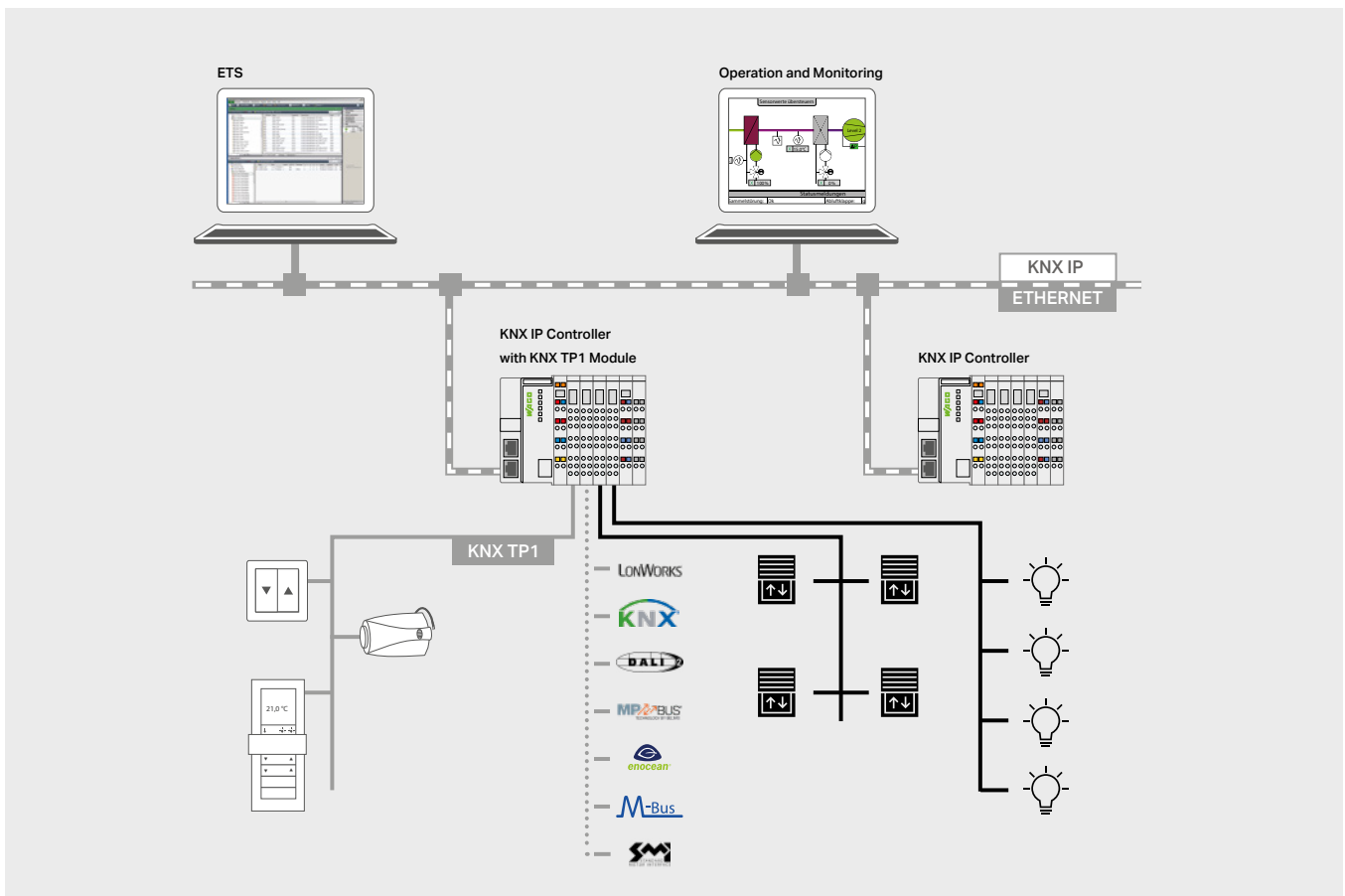

BACnet



Fast Control Solution for Complex Applications

BACnet is a standardized building automation communication protocol that adheres to DIN EN ISO 16484-5. BACnet standardizes communication between products from different manufacturers. Device profiles, services, communication objects, object properties and transmission media have been defined in this standard to meet this goal. WAGO's BACnet Controllers comply with the BACnet Building Controller (B-BC) profile and communicate via **BACnet/IP** or **BACnet MS/TP**.

Additional Benefits

Beyond "BACnet-Building Controller" (B-BC) profile compliance – as defined in the BACnet Standard – WAGO's freely programmable BACnet Controllers are compatible with the associated BACnet Interoperability Building Blocks (BIBBs). A large variety of available input, output and specialty modules for sub-buses – such as KNX, MP-Bus and DALI – complete the system, making WAGO BACnet Controllers incredibly versatile.

WAGO BACnet Configurator

The BACnet Configurator is a useful tool for configuring and operating BACnet controllers in a heterogeneous BACnet network. Logically structuring the network and addressing the controller, as well as configuring both client and server, can be performed on the configuration interface. In addition, the properties of BACnet objects can be accessed using a Web browser.

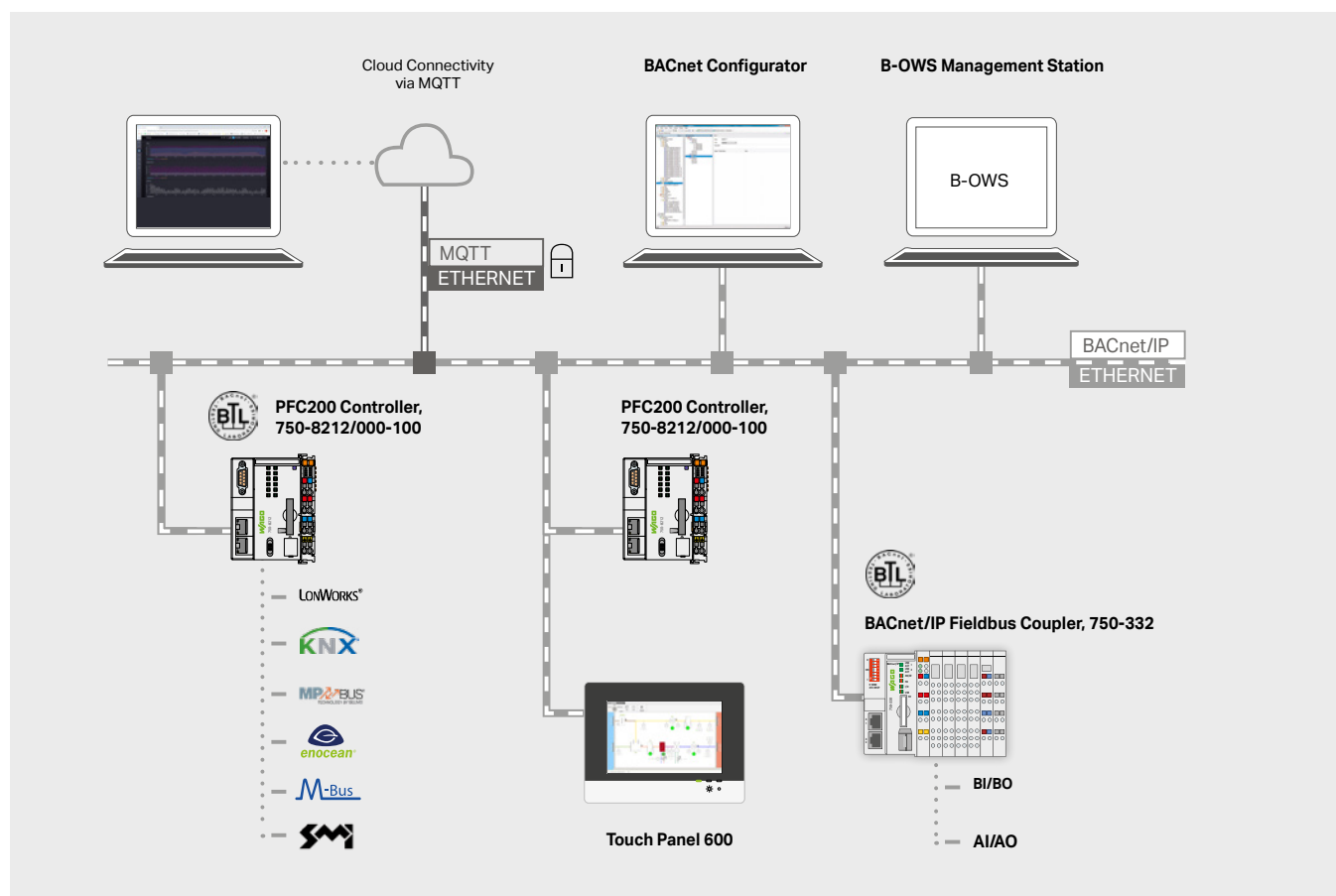



DALI-2

Flexible Solutions and Simple Commissioning

DALI stands for "Digital Addressable Lighting Interface" and is a protocol defined in the IEC Standard 62386. The DALI standard, a protocol common to all manufacturers, substitutes for the 1–10V dimmer interface and ensures the interoperability of DALI devices (e.g., electronic ballasts in lighting applications). A DALI master can control a line with up to 64 devices. In addition, sensors (e.g., brightness measurement and presence detection) can be integrated into a DALI network.



A DALI system allows individual lights or lighting groups to be controlled. No parallel wiring of the control groups is necessary. Assigning individual lights to operating elements and grouping of lights can also be done after installation and is possible at any time without re-wiring.

The DALI-2 standard is delineated by IEC 62386, which defines both the operating devices and the requirements for control devices – among them, the WAGO **DALI Multi-Master Module**. In combination with controllers and I/O modules from the WAGO I/O System, even complex DALI lighting applications can be realized. In addition, the module can function as an interface to numerous fieldbus and sub-bus systems. There is no need to install an additional sensor bus, since sensors can be easily integrated into a DALI network.

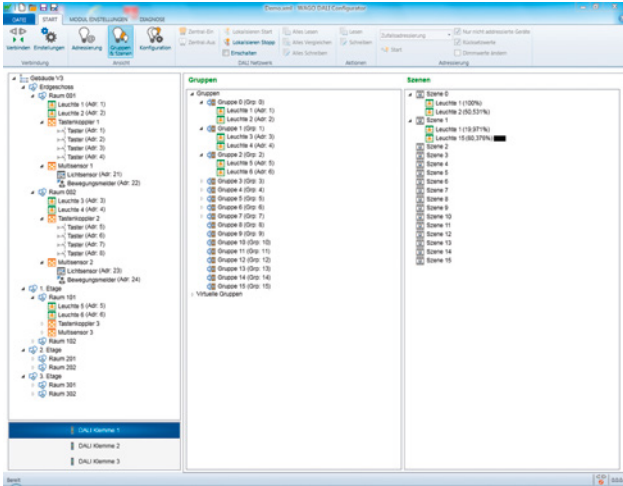

DALI network devices are configured and commissioned using WAGO's DALI Configurator. This tool includes comprehensive functions that simplify and streamline both the installation and maintenance of a DALI network. These functions include: addressing and configuring all DALI network devices, group and scene formation, as well as comprehensive diagnostics.

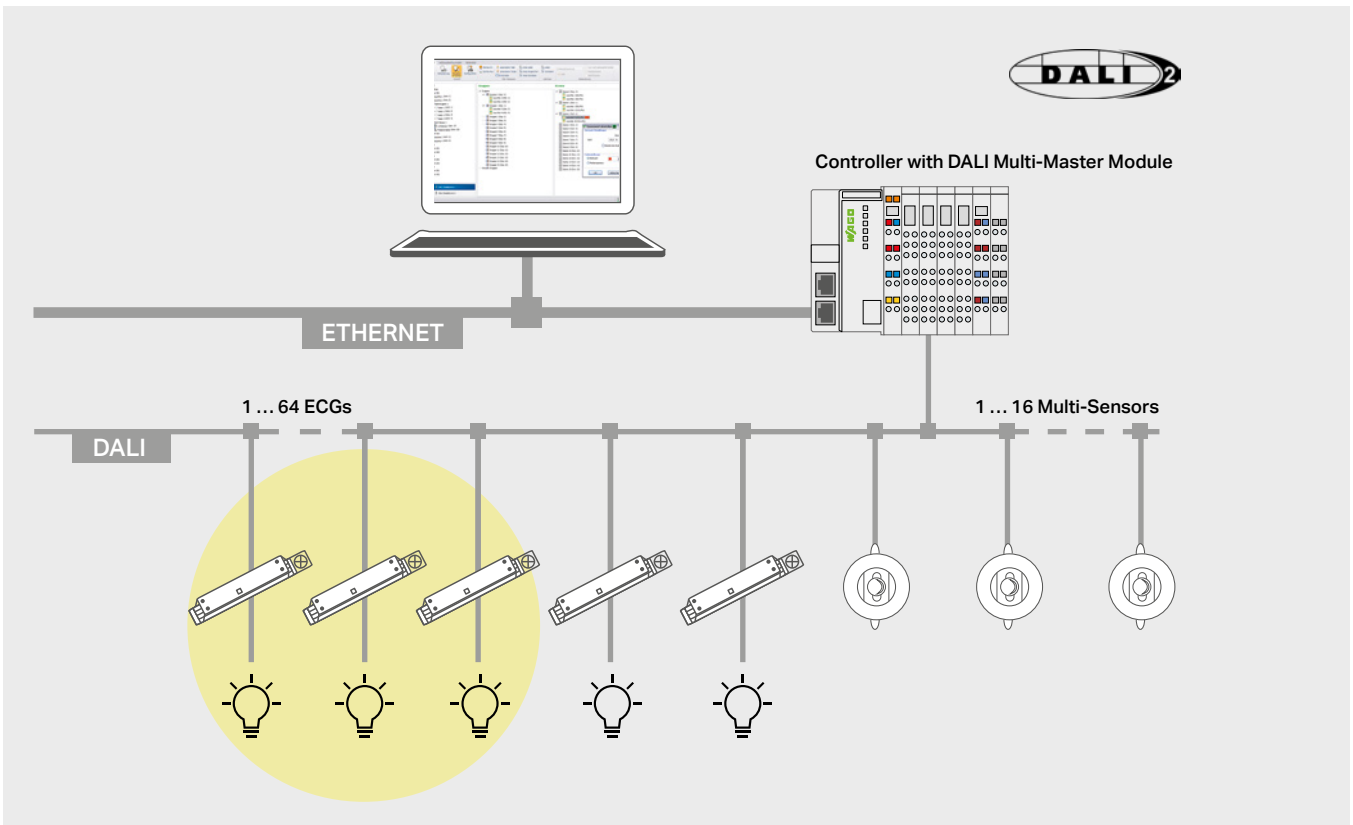

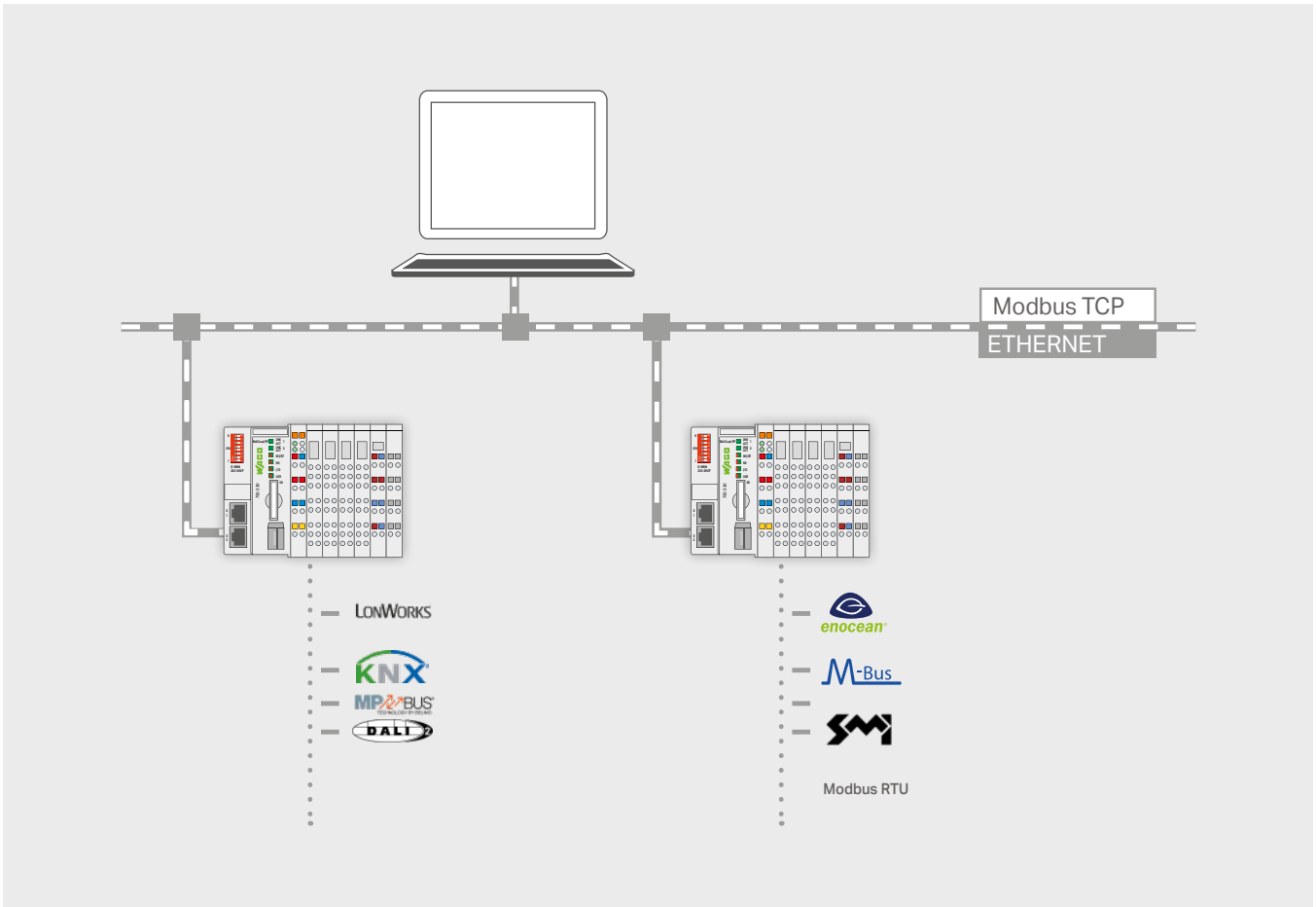

MODBUS/TCP/IP

Fast and Lean Communication

Extending 1979's Modbus TCP protocol for PLCs, the well-established Modbus® protocol has become the de facto standard for building automation. The advantage: Modbus® is a streamlined protocol that ensures ultra-fast ETHERNET data transmission. A manufacturer-independent data structure also permits communication between devices from different manufacturers.

Thus, Modbus TCP is recommended for applications that collect data and/or network intelligent controllers with self-sufficient control logic. Therefore, in addition to the respective fieldbus protocol, WAGO's ETHERNET-based controllers for building automation also support Modbus TCP.



Cybersecurity Directly in the Switch

New Industrial Managed Switch with Integrated Encryption

Cybersecurity is a trending topic in building automation (BA). With the new industrial managed switches from WAGO, users can easily increase the security of their BA applications. The innovation integrates cybersecurity functions: Data packets are encrypted with 128 bits on two ports. This means that it's possible to integrate secure data transmission into an existing network – regardless of the protocol and without changes in the application. The encryption meets the IEEE 802.1AE standard (IEEE MAC Security Standard), ensuring data integrity and authentication of the transmitter with high data throughput.

The optional authentication of the other participants in the network is port-specific in accordance with IEEE 802.1X and RADIUS server. Due to its compact shape (45 x 90 x 110 mm), the new 8-port gigabit switches can be easily retrofitted in the control cabinet. And each switch is equipped with two ports for encrypted communication. With WAGO's 852-1328 Industrial Managed Switch, SFP modules are used for secure communication. This also enables secure networking of distant buildings with optical fibers. Configuration and diagnostics of the industrial managed switches are also performed securely using a Web browser or SNMPv3.

Your Benefits:

- Industrial managed switches with layer 2 encryption (Mac security)
- Retrofit secure data transmission in existing networks
- Network segmentation per IEEE 802.1Q

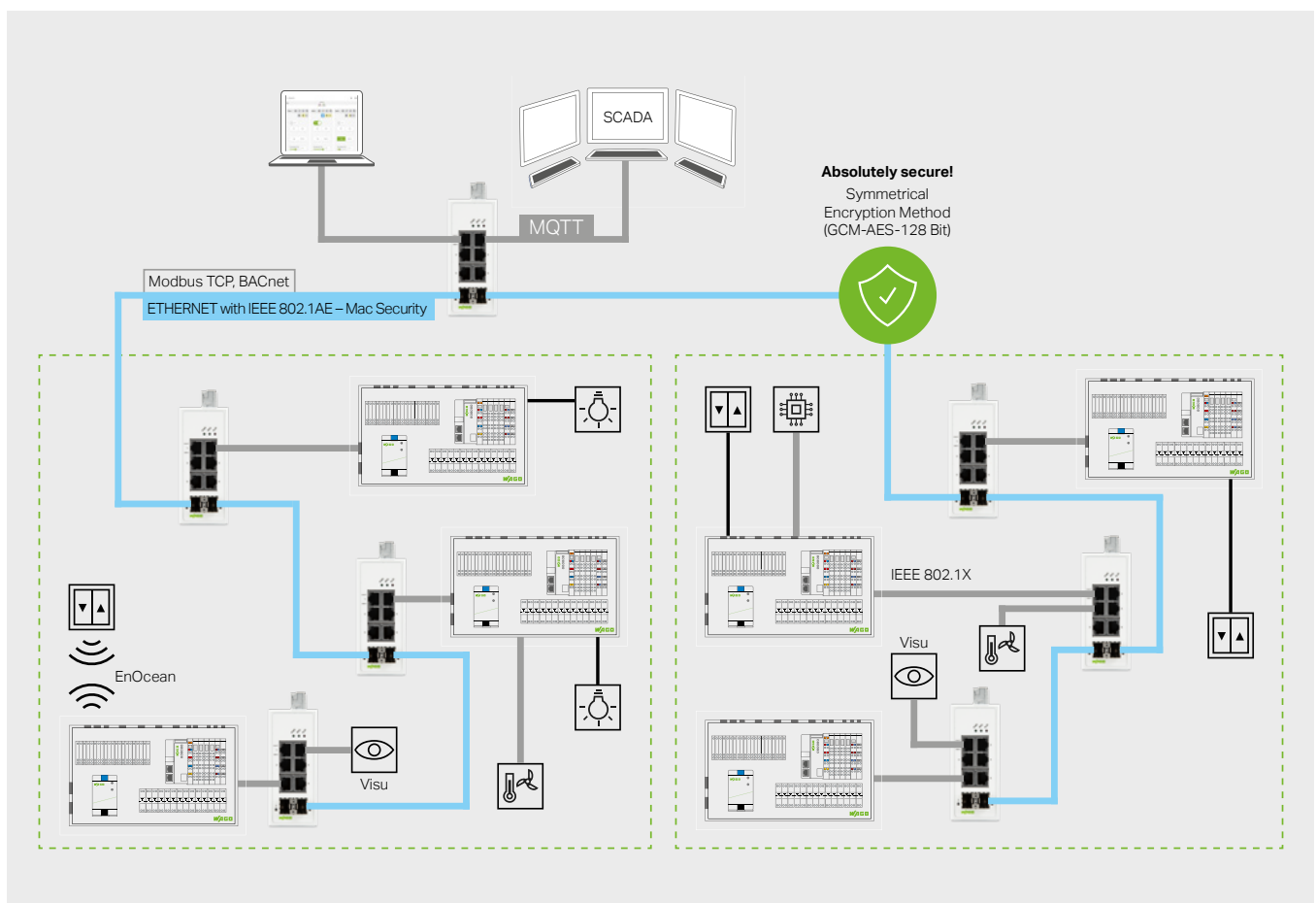

SMI Master

Connect Electrical Drives Directly

A compact design paired with advanced technology: The new SMI Master Module (753-1630) for the WAGO I/O System 750 enables direct connection of electric drives for sunblinds or roller shades without a level inverter.

In addition to reduced wiring expenses, using the new SMI Master also minimizes other costs. A prime example: Since the module has an integrated power supply, an external one is no longer necessary. In addition, a digital output temporarily deactivates the drives when they are not needed.

The 753-1630 SMI Master Module controls 230 VAC SMI motors, and the 753-1631 model can be used with low voltage shade drives (24 V). Up to 16 drives can be connected per module. The SMI Master Module also offers users numerous helpful functions: The "auto-replace" function, for example, allows building operators to replace a defective motor – without modifying the configuration.

WAGO also offers a new SMI Configurator to design and commission SMI networks. The software is used to quickly address the SMI drives and to expedite both the import and export of all configured drives.



EnOcean Radio Technology

Innovative Solutions for Building Automation

WAGO's EnOcean radio technology opens up a new level of innovative building automation solutions, both technically and aesthetically. Wireless switches and sensors based on EnOcean technology harvest available energy to power themselves, e.g., kinetic energy from actuating a switch, or sensors powered by temperature variations or ambient light.

Each transmitter has a unique address and communicates with a receiving unit. Despite the limited energy available, these highly efficient electronics can transmit the signal several times, guaranteeing high transmission reliability.

The EnOcean Dolphin system architecture expands the previous system architecture to include sensors and actuators that communicate bidirectionally. The interoperability of EnOcean Dolphin makes it possible to combine products from different manufacturers into one advanced system.

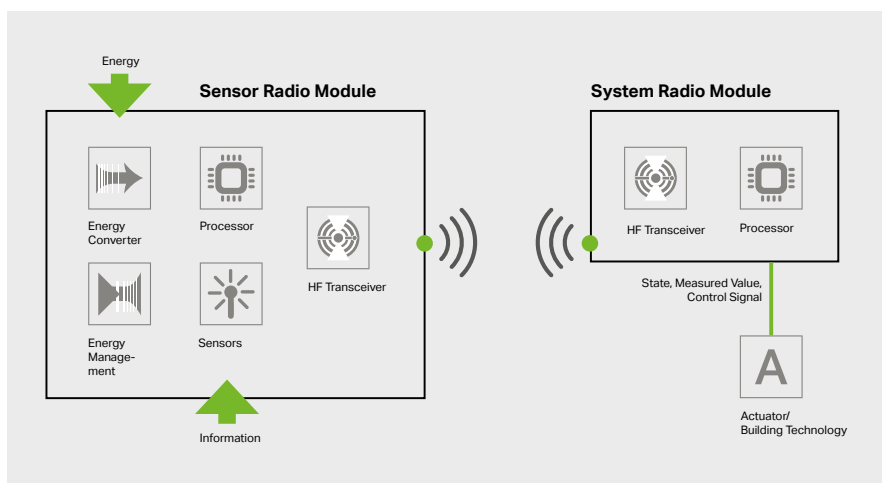

M-Bus Master

Connect Energy and Consumption Meters Directly

Reduce costs, simplify installation, and save space: The 753-649 M-Bus Master Module directly connects up to 40 M-Bus devices to the I/O system to capture consumption data – without external gateways and level inverters.

The M-Bus system, based on a master/slave communication model, can be operated as a line, star or tree topology.



A WAGO Controller with the M-Bus module, which communicates with bus components via 2-wire bus, assumes the role of the master. Up to 40 slaves can be connected per module. The M-Bus transmits data at speeds of 300 to 9600 bps. Regular type J-Y(St)Y N x 2 x 0.8 mm telephone cable, for example, can be used as the M-Bus cabling.

MP-Bus Connection

Control HVAC Actuators

The MP-Bus controls HVAC actuators for dampers, regulator valves or VAV air volume controls.

The actuators connect to sensors (temperature, humidity and on/off switch) that are also accessible via MP-Bus. Devices that are equipped with an MP-Bus connection can communicate with a higher-level control system via bus cable.

Up to eight actuators can be controlled by an MP-Bus master. The 750-643 MP-Bus Master Module can manage up to eight slaves (actuators) and eight sensors (one sensor can be connected to each slave) via common bus cable, significantly reducing actuator and sensor wiring (for MP-bus cable lengths, see 750-643 Module's manual). There is no line topology limitation – star, ring, tree

or mixed configurations are possible. Up to eight slaves can be connected to a master. The actuators feature Multi-Function Technology (MFT) and include: Damper actuators, MFT(2) valve actuators, MFT fire damper actuators, VAV compact controllers and Belimo's FLS window ventilation system. Data exchange between master and slaves is possible (e.g., absolute/relative volumetric flow, minimum/maximum limits, angular position, sensor value, operating status and fault messages).

The WAGO-I/O-PRO Software is required for commissioning the I/O node.





Touch Panels 600

Three Function Classes

Operate, observe, visualize and diagnose in the production, process and marine industries: WAGO's Touch Panels are available in various hardware configurations to support small- to mid-sized control and visualization tasks. Underneath a contemporary design, our Touch Panels pack some of the industry's most powerful technology, augmenting the high-tech image of your machines with high-quality, high-performance visualizations.

Furthermore, scaled functionality is available; besides various functional divisions of the visualization, there's bandwidth for additional operations such as the execution of a control function or support for additional fieldbus systems. The right version with various interface configurations is available for every application.

Web Panel

Operate the PLC Webserver from WAGO through an aesthetic operator interface.

Visu Panel

Share the control load between the PLC and operator interface.

Control Panel

Get an HMI and PLC in one device – a high performance controller with high-quality graphic resolutions.

Additional Technologies

The WAGO I/O System provides users with a wide range of interface solutions for building automation bus systems and subsystems. Beyond the previously mentioned protocols, WAGO also supports:

LonWorks® technology is standardized per ISO/IEC 14908. In addition to BACnet and KNX, LonWorks® is one of the most important protocols in building automation worldwide. A large number of manufacturers use LonWorks® as a communication protocol, allowing interoperable communication between intelligent devices.

DMX is a digital protocol used to control lighting or special stage effects. With the rapid deployment of LED lighting technology, DMX is also used to control LED lights in commercial and utility buildings. DMX displays its strengths in RGB color-control applications (e.g., facade illumination).

LONWORKS®

DMX

Note

Technical Support

www.wago.com/support

Project Support

Find our contact partners at:

www.wago.com/projektunterstuetzung

WAGO Seminars

www.wago.com/seminars



WAGO Kontakttechnik GmbH & Co. KG

Postfach 2880 · D-32385 Minden
Hansastraße 27 · D-32423 Minden

info@wago.com
www.wago.com

Headquarters	+49 (0)571/ 887 - 0
Sales	+49 (0)571/ 887 - 44 222
Orders	+49 (0)571/ 887 - 44 333
Fax	+49 (0)571/ 887 - 844 169

WAGO is a registered trademark of WAGO Verwaltungsgesellschaft mbH.

“Copyright – WAGO Kontakttechnik GmbH & Co. KG – All rights reserved. The content and structure of the WAGO websites, catalogs, videos and other WAGO media are subject to copyright. Distribution or modification of the contents of these pages and videos is prohibited. Furthermore, the content may neither be copied nor made available to third parties for commercial purposes. Also subject to copyright are the images and videos that were made available to WAGO Kontakttechnik GmbH & Co. KG by third parties.”